

2015 safety inspection protocol

- At least **TWO** weeks prior* to your regional all **RANGER** teams are required to **submit to your regional coordinator**:
 - A **company spec sheet**. This is a one page information sheet about the teams and their vehicle.
 - A **systems integration diagram** or SID. SIDs should make a clear distinction between topside and underwater systems. (See the next slide for an example.) SIDs must be completed using a CAD program.
 - Laser specifications, if applicable.

The goal is to provide the safety inspectors with time to review the information and familiarize themselves with the vehicles prior to the contest. If the safety inspector identifies a safety concern, he/she can contact the team(s) in advance OR ask for help from the MATE technical team.

*If your regional requires technical reports to be submitted earlier than weeks prior to your event, these documents may be submitted along with your report.



Example SID

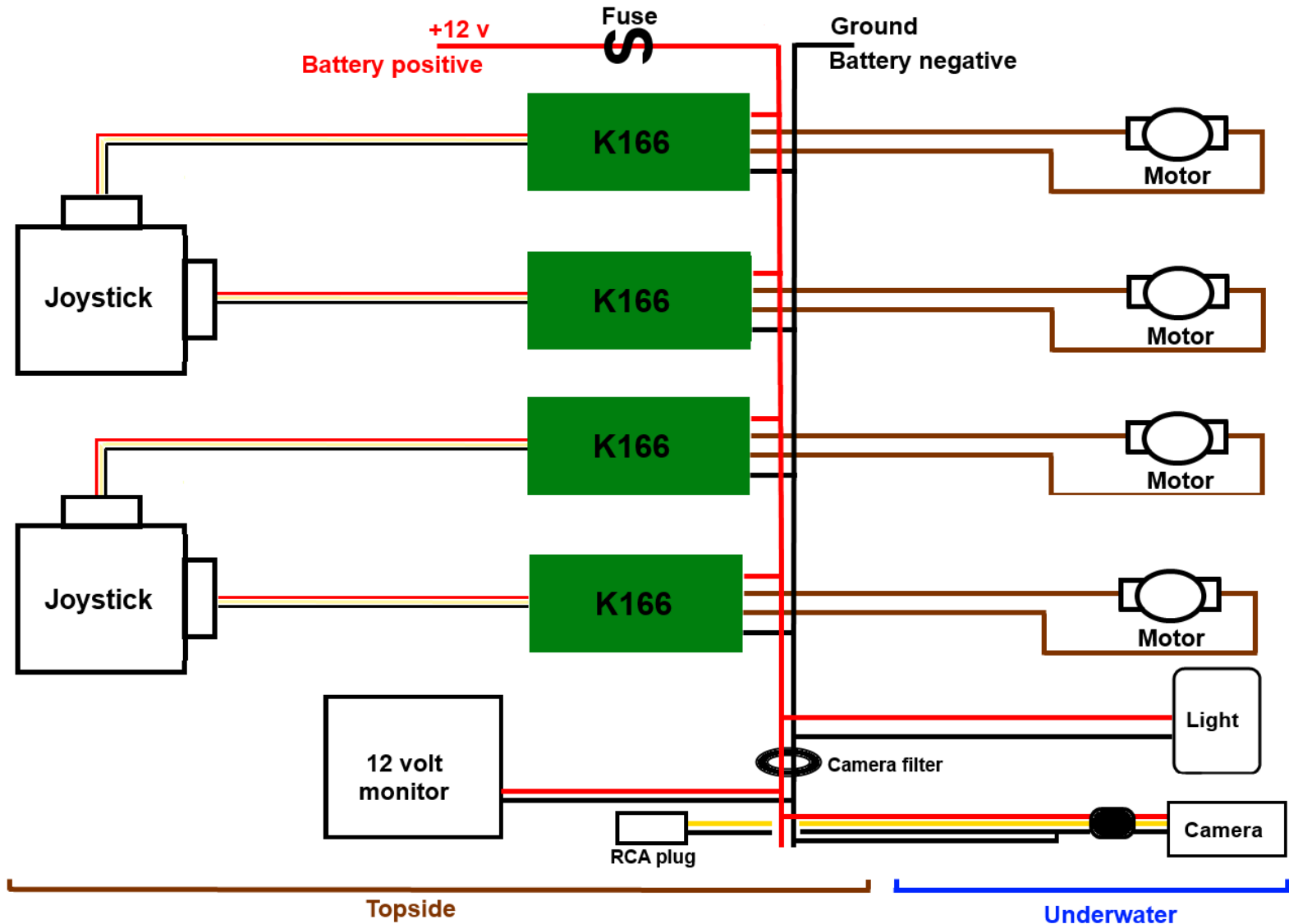

2015 safety inspection protocol

- At least **TWO** weeks prior to your regional all **EXPLORER** teams conducting demos are required to **submit to the MATE Center**:
 - A **company spec sheet**. This is a one page information sheet about the teams and their vehicle.
 - A **systems integration diagram** or SID. SIDs should make a clear distinction between topside and underwater systems. SIDs must be completed using a CAD program.
 - Laser specifications, if applicable.

The MATE technical team will review prior to your event.
Your regional coordinator will be cced on any correspondence.



2015 safety inspection protocol

- On the day of the contest, all **SCOUT** and **NAVIGATOR** teams are required to **submit to your regional coordinator**:
 - A **systems integration diagram** or SID. SIDs should make a clear distinction between topside and underwater systems.

*If your regional requires technical reports to be submitted earlier than 2 weeks prior to your event, these documents may be submitted along with your report.



Fluid power quiz (EXPLORER & RANGER)

- If EXPLORER and RANGER teams are using fluid power (pneumatics or hydraulics), they **MUST** pass the MATE fluid power quiz.
- The date to pass the fluid power quiz is **March 1st 2015**.
- MATE will circulate a list of teams that have passed the fluid power quiz.
- Teams that have not passed the quiz **MAY NOT** use fluid power, **NO EXCEPTIONS**.
- Teams must pass the fluid power quiz to use pneumatics and hydraulics for pool practice or other demonstrations.
- Any team using fluid power must submit a fluid power SID along with their electrical SID two weeks prior to the event.



Fluid power quiz (NAVIGATOR and SCOUT)

- NAVIGATOR and SCOUT class teams **do not** have to take or pass the fluid power quiz. However, all pumps must be hand powered and any container must be open to the pool (see FLUID-003).
- Any NAVIGATOR or SCOUT team using fluid power must submit a fluid power SID along with their electrical SID on the day of the event.



Lasers

- EXPLORER and RANGER class teams must submit laser information to the MATE Center by have any laser pre-approved by **March 1st 2015**. Lasers not approved by the MATE Center are **NOT** permitted to be used during competition.
- MATE will circulate a list of teams that have been approved to use lasers. Teams not on this list **MAY NOT** use lasers on their vehicle.
- NAVIGATOR and SCOUT class teams are **NOT** use permitted to use lasers on their vehicles.

