



2016

# mate roV

competition  
manual

## RANGER

15th annual

# mate roV

international  
competition  
2016

From the Gulf of Mexico to  
Jupiter's Moon Europa:  
ROV Encounters in Inner and Outer Space

MTS marine technology society NOAA NASA NSF OCEANENGINEERING

June 23-25, 2016 Δ NASA's Neutral Buoyancy Lab Δ Houston, Texas

**REVISIONS – 12/3/2015**

Note: All revisions are highlighted in yellow.

Part 1: Product Demonstration – page 4

Part 1: Product Demonstration – Task 4: Inner Space: Deepwater Coral Study – page 27

**REVISIONS – 3/1/2016**

Part 1: Product Demonstration – Task 4: Inner Space: Deepwater Coral Study – pages 27-28

# 2016 MATE ROV COMPETITION:

## *From the Gulf of Mexico to Jupiter’s Moon Europa: ROV Encounters in Inner and Outer Space*

### RANGER CLASS COMPETITION MANUAL

For general competition information, including a description of the different competition classes, eligibility, and demonstration requirements, visit [Team Info](#).

### CONTENTS

<b>OVERVIEW.....</b>	<b>3</b>
<b>THINK OF YOURSELVES AS ENTREPRENEURS.....</b>	<b>3</b>
<b>PART 1: PRODUCT DEMONSTRATION.....</b>	<b>3</b>
<b>OVERVIEW .....</b>	<b>3</b>
<b>SCORING OVERVIEW .....</b>	<b>4</b>
<b>TIME.....</b>	<b>5</b>
<b>RANGER CLASS – REGIONAL PARTICIPATION/DEMONSTRATION .....</b>	<b>6</b>
<b>CONTEXT .....</b>	<b>6</b>
<b>NEED .....</b>	<b>7</b>
<b>REQUEST FOR PROPOSALS (RFP) .....</b>	<b>8</b>
<b>NEW IN 2016!!! SIZE AND WEIGHT RESTRICTIONS.....</b>	<b>15</b>
<b>PRODUCTION DEMONSTRATION.....</b>	<b>17</b>
<b>TASK 1: OUTER SPACE: MISSION TO EUROPA .....</b>	<b>17</b>
<b>TASK 2: INNER SPACE: MISSION-CRITICAL EQUIPMENT RECOVERY.....</b>	<b>22</b>
<b>TASK 3: INNER SPACE: FORENSIC FINGERPRINTING .....</b>	<b>24</b>
<b>TASK 4: INNER SPACE: DEEPWATER CORAL STUDY .....</b>	<b>26</b>
<b>TASK 5: INNER SPACE: RIGS TO REEFS .....</b>	<b>28</b>
<b>TIME BONUS.....</b>	<b>31</b>
<b>PRODUCT DEMONSTRATION RESOURCES .....</b>	<b>31</b>
<b>PART 2: PRODUCT DEMONSTRATION PROP BUILDING INSTRUCTIONS &amp; PHOTOS .....</b>	<b>31</b>

<b>PART 3: VEHICLE DESIGN &amp; BUILDING SPECIFICATIONS .....</b>	<b>32</b>
1.0 GENERAL .....	32
1.1 Glossary and Acronyms .....	32
1.2 Conventions .....	32
1.3 Documentation Required .....	32
2.0 SAFETY.....	34
2.1 Safety Instruction & Observation Program and HSE Awards .....	34
2.2 Safety Pre-inspection .....	37
2.3 Safety Inspection .....	37
2.4 Safety inspection protocol.....	38
2.5 Safety Inspection Points.....	38
3.0 SPECIFICATIONS.....	39
3.1 Operational.....	39
3.2 Mechanical/Physical .....	40
3.3 Electrical .....	41
3.4 Onboard Electrical Power.....	45
3.5 Power Shutdown .....	45
3.6 Fluid Power .....	45
3.7 Control Systems.....	48
3.8 Command, Control, & Communications (C3).....	48
3.9 MATE Provided Equipment .....	49
3.10 Laser Safety Rules .....	50
<b>PART 4: COMPETITION RULES.....</b>	<b>51</b>
GENERAL .....	51
PROCEDURAL .....	52
DESIGN & SAFETY CONSIDERATIONS.....	55
<b>PART 5: ENGINEERING &amp; COMMUNICATION.....</b>	<b>56</b>
TIPS FOR EFFECTIVE WRITTEN AND ORAL COMMUNICATION .....	56
COMPANY SPEC SHEET (ONE PAGE ONLY) .....	58
TECHNICAL DOCUMENTATION .....	58
PRODUCT PRESENTATION .....	61
MARKETING DISPLAY .....	65
BONUS POINTS FOR MEDIA OUTREACH – INTERNATIONAL COMPETITION .....	69

## OVERVIEW

### THINK OF YOURSELVES AS ENTREPRENEURS

From deepwater oil drilling to the exploration of shipwrecks and installation of instruments on the seafloor, individuals who possess entrepreneurial skills are in high demand and stand out in the crowd of potential job candidates. What are entrepreneurial skills? They include the ability to understand the breadth of business operations (e.g., finances, research and development, media outreach), work as an integral part of a team, think critically, and apply technical knowledge and skills in new and innovative ways.

To help you to better understand and develop these skills, the MATE ROV competition challenges you to think of yourself as an entrepreneur. Your first task is to create a company or organization that specializes in solutions to real-world marine technology problems. Use the following questions as a guide.

- What is your company name?
- Who are its leaders – the CEO (chief executive officer – the leader) and CFO (chief financial officer who oversees the budget and spending)?
- Who manages Government and Regulatory Affairs (i.e. who’s in charge of reviewing the competition rules and making sure that they are understood and followed by everyone)?
- Who is responsible for research and development (R&D)?
- Who is responsible for system(s) engineering? Design integration? Testing? Operations?
- Who is responsible for fund-raising, marketing, and media outreach?
- What other positions might you need? (Depending on your personnel resources, more than one person may fill more than one role.)
- What products and services do you provide?
- Who are your potential clients?

In this case, the MATE Center, the NASA Johnson Space Center’s Neutral Buoyancy Lab, and Oceaneering International are your “clients” who recently released a request for proposals. A request for proposals (RFP) is a document that an organization posts to solicit bids from potential companies for a product or service. The specifics of your product design and rules of operation as well as the specifics of your product demonstration are included below.

## PART 1: PRODUCT DEMONSTRATION

### OVERVIEW

**RANGER** class companies will take part in ONE product demonstration that consists of five distinct tasks:

#### **TASK #1: OUTER SPACE: MISSION TO EUROPA**

Measure the temperature of water emerging from a vent; determine the thickness of the ice and depth of the ocean; and connect an Environmental Sample Processor (ESP) to a power and communications hub.

## **TASK #2: INNER SPACE: MISSION-CRITICAL EQUIPMENT RECOVERY**

Use serial numbers to identify mission-critical equipment and transport the equipment to a collection basket for later recovery.

## **TASK #3: INNER SPACE: FORENSIC FINGERPRINTING**

Collect two samples of oil from the sea floor, return the samples to the surface, and analyze gas chromatographs to determine the samples' origin.

## **TASK #4: INNER SPACE: DEEPWATER CORAL STUDY**

Take still photographs of two coral colonies and evaluate those photographs to determine whether the coral colonies are growing, stable, or decreasing in size. Collect two samples of another coral species and return the samples to the surface.

## **TASK #5: INNER SPACE: RIGS TO REEFS**

Attach a flange to the top of a decommissioned wellhead, install a wellhead cap to the top of the flange, and secure both the flange and the wellhead cap with bolts.

**NOTE:** Regional competitions may not include all 5 tasks within the product demonstration; regional competitions may also give companies more than one attempt at the product demonstration. Contact your [regional coordinator](#) to determine what will take place your regional competition. Regardless, the product demonstration score will be added to your [ENGINEERING & COMMUNICATION](#) and [SAFETY](#) scores to determine your total, overall score for the competition.

## **SCORING OVERVIEW**

The competition consists of product demonstrations, technical documentation, product presentations, marketing displays, and safety with the following scoring breakdown:

- **Product demonstrations**
  - 260 points (max), plus a time bonus
  - Size and weight restrictions
    - 40 points (max)
  - Product demonstration safety and organizational effectiveness
    - 20 points (max)
- **Engineering & Communication** – 260 points (max)
  - Technical documentation
    - 100 points (max)
  - Product presentations
    - 100 points (max)
  - Marketing displays
    - 50 points (max)
      - International competition ONLY – 5 bonus points for media outreach
  - Company Spec Sheet

- 10 points (max)
- **Safety**
  - 30 points (max)
  - International competition\* – points for safety observation program, including Job Safety Analysis (JSAs)

**TOTAL POINTS (not including the media bonus or safety observation program) = 610**

**NOTE: Regional contests may not require all of the Engineering & Communication components. Contact your [regional coordinator](#) for more information.**

## TIME

Each product demonstration includes:

- 5 minutes to set up at the product demonstration station
- 15 minutes to attempt the tasks
- 5 minutes to break down and exit the product demonstration station

Your company will have 5 minutes to set up your system, 15 minutes to complete the tasks, and 5 minutes to demobilize your equipment and exit the product demonstration station. During the 5-minute set-up, you may reassemble your vehicle after the size determination and weigh-in and place it in the water for testing and/or trimming purposes, provided that a company member has a hand on the vehicle at all times and uses extreme caution. The 15-minute demonstration period will begin after the full 5 minutes of set up time expires, regardless of whether the company is ready to start the product demonstration. It may begin sooner if your CEO notifies the product demonstration station judges that your company is ready to begin.

At any time during the demonstration, you may pilot your ROV to the surface and remove the vehicle from the water for such things as buoyancy adjustments, payload changes, and troubleshooting, but the 15-minute product demonstration clock will only be stopped by a judge who determines it is necessary for reasons beyond your control. Otherwise, the clock will only stop after all of the tasks are successfully completed, the ROV has returned to the surface under its own power so that it touches the side of the pool, and a company member at the product demonstration station has physically touched the vehicle. Your ROV is not required to return to the surface between tasks.

Your 5-minute demobilization will begin as soon as the 15-minute demonstration time ends, regardless of where your ROV is located (i.e., still at depth, on the surface, etc.).

Regional competitions may alter the set-up, product demonstration time, or demobilization time. Contact your [regional coordinator](#) to verify the timing of your product demonstrations.

## TIME BONUS

Companies will receive a time bonus for each product demonstration if you:

- 1) successfully complete all the tasks,
- 2) return your ROV to the surface under its own power so that it touches the side of the pool, and
- 3) physically touch your vehicle before the demonstration time ends.

Companies will receive 1 point for every minute and 0.01 point for every second under 15 minutes remaining.

## RANGER CLASS – REGIONAL PARTICIPATION/DEMONSTRATION

**All companies participating in the RANGER class are required to take part in a regional event.** Companies that win their regional event can move on to compete in the RANGER class at the international competition.

Companies will be assigned to the regional that is geographically closest to their location. If companies are located equidistant from two or more regionals, the MATE competition coordinator and the coordinators of those regionals will discuss with the company which regional is most appropriate.

RANGER class companies that are prohibitively far from a regional event should contact the [MATE Center \(ljzande@marinetech.org\)](mailto:ljzande@marinetech.org) for information about conducting a video demonstration.

NO RANGER class companies will be permitted to participate in the international competition without either 1) winning their regional event or 2) submitting a video demonstration that is then approved by MATE competition officials.

## CONTEXT

Since its inception in 1958, the National Aeronautics and Space Administration (NASA) has accomplished many great scientific and technological feats in air and space. However, NASA's work and impact is not limited to aerospace. NASA technology also has been adapted for many non-aerospace uses by the private sector; the technique of freeze-drying food is one example.

The agency also plays a role in ocean science and exploration. NASA has been observing the earth's oceans from space for decades. NASA launched Seasat, the first civilian oceanographic satellite, on June 28, 1978. Seasat was followed by Tiros-N. Today there are several ocean-observing satellite missions and an extensive scientific research community studying this data. Satellite data and modeling techniques allow scientists to map and monitor seasonal changes in ocean surface topography, currents, waves, winds, phytoplankton content, sea-ice extent, rainfall, sunlight reaching the sea, and sea surface temperature. During the last decade, forecasting models used NASA's satellite data to improve the ability to predict events such as the El Niño climate oscillation phenomenon and other global and regional climate cycles.

Similarly, global oilfield services provider Oceaneering International's work is not only in subsea oilfield production; the company's Entertainment Systems division contributes to the cutting-edge development of theme park technologies (think Disney!), including dark ride vehicles and show systems. Oceaneering also has



divisions that focus on land surveying and mapping, video and data collection and management, and outer space.

Oceaneering's Space Systems (OSS) division develops, integrates, and applies both new and existing technologies to the challenges of operations in space and other harsh environments. OSS specializes in the design, manufacturing, certification, maintenance, and testing of thermal protection systems for rockets; equipment for humans to use in space; and robotic systems for military, space, and biological research applications. The Space Systems division of Oceaneering also provides specialized engineering and support services in these areas and in astronaut training at NASA's Johnson Space Center's Neutral Buoyancy Laboratory (NBL) and Space Vehicle Mockup Facility (SVMF).

OSS is one of several in-house commercial tenants at the NBL/SVMF that supports NASA's programs. The company oversees astronaut training for extravehicular activities (EVAs or "spacewalks") and intravehicular activities (IVAs or activities that take place inside the spacecraft). OSS also teams with NASA scientists and engineers to find solutions to problems as well as ways to accomplish NASA priorities – such as recovering mission-critical equipment from the ocean floor and developing robots to explore oceans on other planets and natural planetary satellites in our galaxy.

In addition to working together, both NASA and Oceaneering partner with other organizations that have similar project interests and priorities. Given the location of their facilities, this includes organizations with scientific, commercial, and conservation efforts taking place in the Gulf of Mexico.

## **NEED**

NASA and Oceaneering Space Systems (OSS) have issued a request for proposals (RFP) for a first-of-its-kind, dual purpose remotely operated vehicle that can operate in the harsh environments of both the deep ocean and outer space. Specifically, scientists and engineers at these organizations are in need of a robot that can 1) survive transport to Jupiter's moon Europa and operate in the ocean under its ice sheet to collect data and deploy instrumentation; 2) find and recover critical equipment that sank in the Gulf of Mexico after a recent series of testing programs; 3) collect samples and analyze data from oil mats located in the northern Gulf of Mexico to determine their origin ; 4) photograph and collect samples of deep-water corals to assess their health post-Deepwater Horizon oil spill; and 5) prepare a wellhead for decommission and conversion into an artificial reef.

Before launch and operations in inner and outer space, the robot must complete a series of "product demonstrations" staged in the 6.2-million gallon, 40-foot deep Neutral Buoyancy Lab (NBL). (Depth requirements vary depending on robot class; see [VEHICLE DESIGN & BUILDING SPECIFICATIONS](#) below.) Companies that successfully complete the product demonstrations and deliver exceptional engineering and communication components (e.g. technical documentation, product presentations, and marketing displays) will be awarded the contract.

**This is where your work begins.**

Visit [www.youtube.com/watch?v=Tn-jUbpFV4A](http://www.youtube.com/watch?v=Tn-jUbpFV4A) for sound advice from MATE judge Marty Klein. He references 2015, but his words still hold true for this competition season!

## REQUEST FOR PROPOSALS (RFP)

### 1. General

#### a. Mission to Europa

NASA's Galileo mission to Jupiter in the late 1990s produced strong evidence that Europa, one of Jupiter's moons that is about the size of Earth's moon, has an ocean beneath its frozen crust. Additional evidence was gathered in 2012, when the Hubble Space Telescope observed water vapor above Europa's southern polar region. If proven to exist, this global ocean could hold more than twice as much water as Earth. With abundant salt water, a rocky sea floor, and the energy and chemistry provided by tidal heating, Europa may have the ingredients needed to support simple organisms.

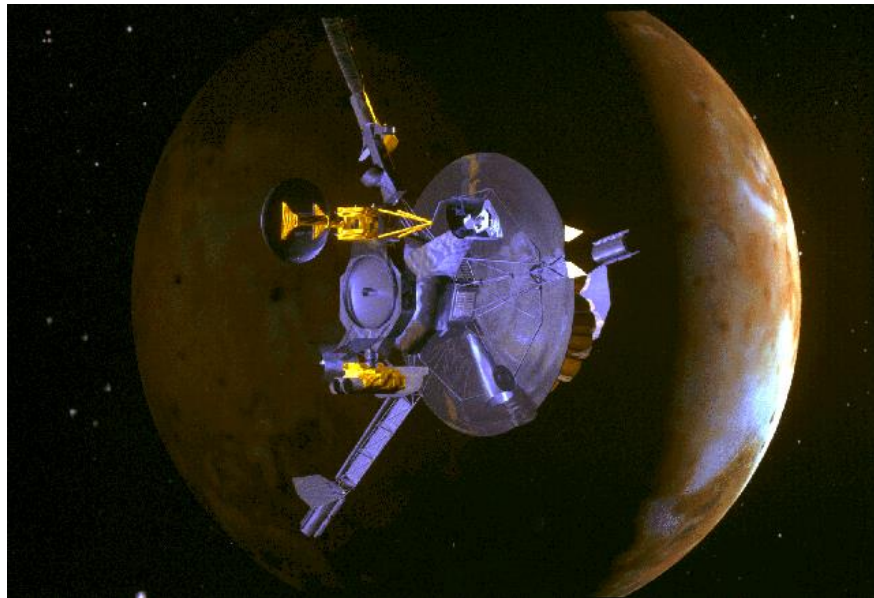

On December 16, 1997, the Galileo spacecraft flew within 200 km of Europa's surface, allowing its cameras to resolve details as small as 6 meters.

Photo credit: [http://physics.weber.edu/carroll/europa/galileo\\_mission\\_to\\_europa.htm](http://physics.weber.edu/carroll/europa/galileo_mission_to_europa.htm)

All systems are go for a reconnaissance mission to Europa. NASA will launch a highly capable, radiation-tolerant spacecraft to Jupiter in the 2020s. When it arrives several years later, the spacecraft will enter into a long, looping orbit around Jupiter to perform repeated, close flybys of Europa. The mission plan currently includes 45 flybys at altitudes varying from 2,700 to 25 kilometers.

The spacecraft's payload will include cameras and spectrometers to produce high-resolution images of Europa's surface and determine its composition. An ice-penetrating radar will determine the thickness of the moon's icy shell and search for subsurface lakes similar to those

beneath Antarctica's ice sheet. The mission will also carry a magnetometer to measure the strength and direction of the moon's magnetic field, which will allow scientists to determine the depth and salinity of its ocean.

Based on the findings gathered from this reconnaissance, NASA will propose a second mission to Europa, this one with the goal of landing on the moon's icy surface. The mission plan would include penetrating the ice sheet to perform detailed, long-term investigations of the waters and seafloor below, with the hope of finding evidence of life elsewhere in our galaxy.

#### **b. Mission-Critical Equipment Recovery**

CubeSats are miniaturized satellites; they are part of a class of research spacecraft called nanosatellites. The CubeSat concept was developed in 1999 by professors at California Polytechnic State University, San Luis Obispo and Stanford University's Space Systems Development Lab. Their goal was to enable graduate students to design, build, test, and operate a spacecraft with capabilities similar to that of the first spacecraft, Sputnik.

The first CubeSat was launched in 2003. Today, more than 60 universities and high schools participate in the CubeSat Project managed by these two universities.



Student-built CubeSats are released from the international space station's Kibo module.

Photo credit: NASA.

The CubeSat that was initially proposed did not set out to become the "standard," but over time it became just that. CubeSats are built to standard dimensions (Units or "U") of 10cm x 10cm x 11cm. They can be 1U, 2U, 3U, or 6U in size, and typically weigh less than 1.33 kg (3 lbs) per U. CubeSats are most commonly put in orbit by deployment systems on the International Space Station or launched as secondary payloads on a launch vehicle.

These tiny, box-shaped spacecraft have emerged in the last 16 years as a quick, viable way to test components and techniques that, if proven, can be applied to much larger missions where the stakes are far greater than a simple, 10cm cube. The price tag for each mission is one-tenth the cost of the least-expensive traditional launcher.

Academia accounted for the majority of CubeSat launches until 2013, when over half of the launches were for non-academic purposes. By 2014, most newly deployed CubeSats were for a commercial or amateur project. CubeSats have been built by large and small companies alike; some have been the subject of Kickstarter campaigns. These mini-satellites are revolutionizing the space industry by placing the ability to conduct space science and exploration in the hands of students, teachers, working professionals, and Makers of all ages.

Recognizing the benefits to the space community, NASA supports CubeSat development and research through its CubeSat Launch initiative (CSLI). The CSLI provides opportunities for CubeSats to fly on rockets planned for upcoming launches. The CubeSats essentially “piggyback” as auxiliary payloads on previously planned missions, collecting information, testing new technologies, and furthering what we know about outer space.

#### **c. Forensic Fingerprinting**

The Deep-C (Deep Sea to Coast Connectivity in the Eastern Gulf of Mexico) Consortium was created as a result of the Deepwater Horizon oil spill in 2010. While the overarching goal of the Consortium is to study the long-term effects of the spill, new technologies used by Deep-C scientists have global impacts on scientific research. One technological advancement is the ability to thoroughly “fingerprint” oil samples.

The term fingerprinting has become commonly used shorthand for determining a substance’s origin or source. For example, in DNA fingerprinting such as seen in TV shows like CSI, investigators match the presence or absence of specific gene sequences to that seen in DNA samples of known origin.

Oil is a complex mixture of various hydrocarbons (carbon-containing compounds of different molecular weights) and associated impurities. Some of these hydrocarbons have molecular weights that cause them to be gaseous at temperatures and pressures found in the ocean, while others are liquids of various viscosity or “stickiness.” Oil from different sources varies in the specific hydrocarbons present as well as in the abundance of these hydrocarbons (and impurities). Therefore, in a manner analogous to DNA, oil can be fingerprinted to a specific source or origin.

Chromatography is a scientific tool that separates mixtures based on their different chemical and physical properties such as molecular weights. In general, gas or liquid chromatography works by combining a sample with some type of non-reactive carrier molecule that transports the sample through a column. The column contains chemical compounds that retain the various components

of the sample based on their properties, such as molecular weight. The resulting data can be represented in a chromatogram, a graph of the abundance of the various components versus retention time in the column.

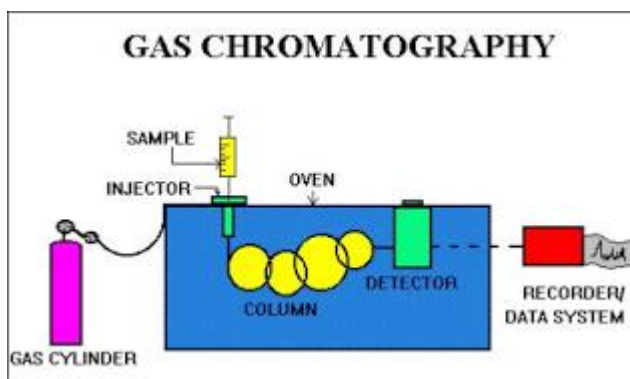

Photo credit: <https://sites.google.com/site/advancedmagicofforensicscience/lesson-3>

Trying to separate mixtures of very similar molecular weight compounds requires a more involved process, known "GC x GC" (gas chromatography x gas chromatography). In the GC x GC technique, there are two columns; after the sample flows through the first column, parts of the sample are collected and injected into the second column, which results in greater separation. This powerful new technique is increasing scientists' ability to produce a more detailed fingerprint and, therefore, more accurately determine the origin of events like an oil spill.

#### d. Deepwater Coral Study

During the three months between the Deepwater Horizon oil rig explosion and when the Macondo wellhead was capped on July 15, 2010, approximately 4.1 million barrels (~650,000 m<sup>3</sup>) of crude oil were released into the Gulf of Mexico at 1,520 m depth. Because of the physics of the spill, as well as the extensive use of dispersants, much of the oil and gas remained at depth. In addition, weathering, burning, and the application of dispersants to surface slicks resulted in a return of hydrocarbons to the deep sea. These hydrocarbons and dispersants had the potential to harm numerous deep-sea communities that are, by nature, difficult to access and assess. These communities include species of colonial, cold-water corals.

Most deepwater corals, including *Paramuricea* species, are slow-growing; individual gorgonian colonies (also known as sea whips or sea fans) can live for hundreds to thousands of years. As a result, these corals and the communities that form on and in association with them are unlikely to recover quickly from events that are lethal to significant portions of the corals.

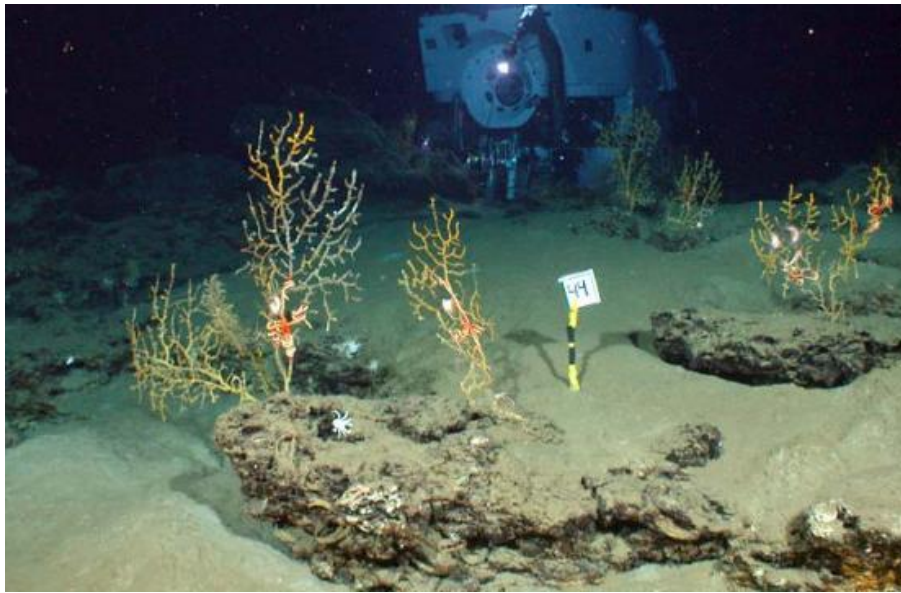

Shortly after the spill, researchers found coral at the bottom of the Gulf of Mexico covered with “black scum” and a gooey brown mixture of material 11 km southwest of the Macondo wellhead.

Photo credit: Chuck Fisher, Penn State University, and Tim Shank, Woods Hole Oceanographic Institution; [www.cnn.com/2012/03/26/us/gulf-oil-coral/](http://www.cnn.com/2012/03/26/us/gulf-oil-coral/)

Scientists began studying the effects of the massive spill on Gulf of Mexico deepwater coral species within three months after the well was capped. In addition to colonies of *Paramuricea* species, they investigated scleractinian, also called stony or hard, coral species. While samples were collected for laboratory analysis, care was taken not to cause additional damage to the organisms. Scientists also used non-invasive methods. These included collecting and digitizing still images so that they could be analyzed for signs of visible impact and compared to subsequent photos to assess the spill’s effect on the corals over time.

#### e. Rigs to Reefs

“Rigs-to-Reefs” is the practice of converting decommissioned offshore oil and gas platforms into artificial reefs to support marine habitat. In the United States, where the practice started and is most common, Rigs-to-Reefs is a nationwide program developed by the Bureau of Ocean Energy Management (BOEM) and the Bureau of Safety and Environmental Enforcement (BSEE) of the U.S. Department of the Interior.

Oil platforms make ideal reefs because they are environmentally safe, are constructed of highly durable and stable material, and already support a thriving reef ecosystem below the waterline since many of the structures have been in the water for 30 years or longer. From a rig to a reef the transformation begins quickly. Marine species, including fish, find the structure immediately. Invertebrates settle within a month, and after six months to a year, the site is well established as an artificial reef.



Scuba divers are yet another species that benefits from the Rigs-to-Reef program.

Photo credit: [www.rig2reefexploration.org/](http://www.rig2reefexploration.org/)

The structures are inspected before any reefing takes place to locate environmental hazards. All decks (where oil production occurs) are removed and taken to shore for recycling or reuse. All equipment associated with the deck is removed in the process (such as drilling equipment, tanks, pumps, buildings, etc.). Insides of legs are inspected to ensure that they contain no petroleum. All wells below the structure are “plugged” – or capped – by the company that owns the platform, according to standards set by the BOEM. Once the cap is secured, the structure’s life as oil platform ends and its tenure as a home to marine species officially begins.

**f. Document Scope and Purpose**

This and the following sections contain the technical specifications and requirements for ROV services needed to support both the space and ocean science and technology community. In 2016, ROV services include:

**1) MISSION TO EUROPA**

- Measuring the temperature of venting fluid.
- Determining the thickness of the ice crust.
- Determine the depth of the ocean under the ice.
- Connecting the Environmental Sample Processor (ESP) to the power and communication hub.
  - Retrieving the ESP’s cable connector from the elevator.
  - Laying the ESP cable through two waypoints.
  - Opening the door to the port on the power and communications hub.
  - Inserting the cable connector into the port on the power and communications hub.

**2) MISSION CRITICAL EQUIPMENT RECOVERY**

- Positioning equipment to find the four desired serial numbers.

- Transporting the equipment and placing it in a collection basket.

### **3) FORENSIC FINGERPRINTING**

- Retrieving oil samples from the seafloor.
- Returning oil samples to the surface.
- Analyzing a gas chromatograph of each sample to determine its origin.

### **4) DEEPWATER CORAL STUDY**

- Photographing two coral colonies.
- Comparing images to previous years and assessing their condition.
- Returning two coral samples to the surface.

### **5) RIGS TO REEFS**

- Installing a flange to the top of the wellhead.
- Securing the flange to the wellhead with one bolt.
- Installing a wellhead cap over the flange.
- Securing the cap to the flange with two bolts.

## **2. Specifications**

See the specific tasks described below as well as the [VEHICLE DESIGN & BUILDING SPECIFICATIONS](#) and [COMPETITION RULES](#) sections.

## **3. Maintenance and Technical Support**

The company shall warrant the ROV and associated systems and equipment for at least the duration of the product demonstrations. Repair or replacement shall be at the company's expense, including the cost of shipping the ROV to and from the competition facility.

During regional events, the company shall provide at least one day of technical support to resolve hardware, software, and operational issues. They shall provide at least three days of the same for the international event.

## **4. Shipping and Storage**

Refer to [Shipping Information](#) for specifics on shipping to the international competition site.

Delivery of the ROV and associated systems and equipment shall be no later than the date of the geographically closest regional contest or by June 23, 2016, which is the start date of the international competition.

## **5. Evaluation Criteria**

- a. Technical documentation
- b. Product presentation
- c. Marketing display



- d. Product demonstration

## 6. References

- a. [www.nasa.gov](http://www.nasa.gov)
- b. [www.nasa.gov/europa](http://www.nasa.gov/europa)
- c. <http://science.nasa.gov/earth-science/oceanography/>
- d. [www.oceaneering.com](http://www.oceaneering.com)
- e. [www.nasa.gov/press-release/all-systems-go-for-nasas-mission-to-jupiter-moon-europa](http://www.nasa.gov/press-release/all-systems-go-for-nasas-mission-to-jupiter-moon-europa)
- f. [www.cubesat.org/](http://www.cubesat.org/)
- g. [www.nasa.gov/mission\\_pages/cubesats/index.html](http://www.nasa.gov/mission_pages/cubesats/index.html)
- h. <https://en.wikipedia.org/wiki/CubeSat>
- i. <http://deep-c.org/>
- j. <https://elementascience.org/articles/12>
- k. [www.pnas.org/content/111/32/11744](http://www.pnas.org/content/111/32/11744)
- l. [www.bsee.gov/Exploration-and-Production/Decommissioning/Rigs-to-Reefs/](http://www.bsee.gov/Exploration-and-Production/Decommissioning/Rigs-to-Reefs/)
- m. <https://en.wikipedia.org/wiki/Rigs-to-Reefs>
- n. [http://tpwd.texas.gov/landwater/water/habitats/artificial\\_reef/rigs-to-reefs.phtml](http://tpwd.texas.gov/landwater/water/habitats/artificial_reef/rigs-to-reefs.phtml)

**IMPORTANT NOTE: Questions about production demonstrations and design and building specifications must be posted to the competition FAQs board located at [www.marinetech.org/forums/](http://www.marinetech.org/forums/). This allows all companies to see the questions and answers and helps to avoid duplicate questions. That said, please make sure that your question(s) has not already been asked – and answered – before posting. It is up to the companies to read, comprehend, and comply with ALL rulings posted on the FAQ board.**

## ***NEW IN 2016!!!***

### **SIZE AND WEIGHT RESTRICTIONS**

Launching payloads into orbit can cost NASA in excess of ~\$20,000 USD per kilogram;\* limiting the size and weight of objects launched into space is very important. In 2016, RANGER class vehicles will have a size limit that they may not exceed. In addition, bonus points will be awarded to companies that design smaller, lighter vehicles.

Vehicles will be measured and weighed in the RANGER on-deck circle 45 minutes prior to the company's product demonstration runs. Note that the vehicle will be measured and weighed before all product demonstration runs. The size and weight bonus, if any, will be added into the product demonstration score.

### **Size Measurements**

Size measurements will be made using the two largest dimensions of the ROV. Four flat sheets with 48 cm, 54 cm, 60 cm, and 75 cm diameter holes cut into their centers (one hole per sheet) will be located on a table in the on deck circle. Companies will place their vehicles on the table and, when ready, ask a MATE Center competition official to make the size measurement. The vehicle measurement must include the vehicle, all manipulators/tools that will be used in the product demonstration as well as the vehicle's tether. The control system and 1 meter of tether may be outside of the measurement circle. Companies may detach manipulator

arms and other equipment and place that equipment, next to, on top of, or inside the vehicle frame, but all of the equipment that will be used must be present and fit within the measurement circle. For example, a company may remove a manipulator arm that extends 20 cm in front of the vehicle and place it on top of the vehicle. The measurement will be made with the arm on top of the vehicle provided that the length and width are still the largest diameters.

The hole in the flat sheet must fit over the two largest dimensions of the ROV. If the ROV and all its equipment fit within the hole of 48 cm in diameter, the company will receive +20 bonus points. If the ROV and all its equipment fit within the hole of 54 cm in diameter, the company will receive +10 bonus points. If the ROV and all its equipment fit within the hole of 60 cm in diameter, the company will receive +5 bonus points. If the ROV and all its equipment fit within the hole of 75 cm in diameter, the company will receive no bonus points, but can still compete in the product demonstration. If the ROV and all its equipment do not fit within the 75 cm in diameter hole, the company will not be permitted to compete in that product demonstration run.

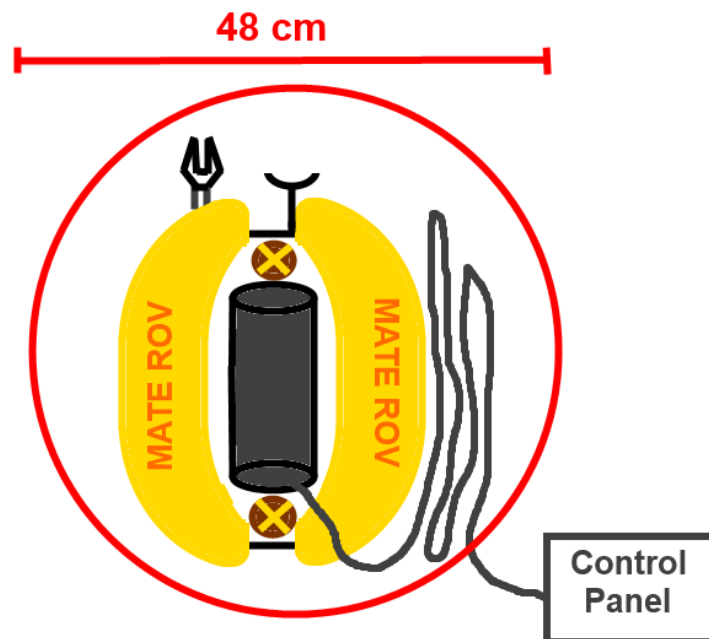

*A RANGER class vehicle, with tools attached and tether coiled beside the ROV, inside the 48 cm diameter circle. This vehicle would earn the company +20 bonus points on the product demonstration score.*

### **Weight Measurements**

Weight measurements will be conducted using a hanging digital scale. The MATE Center will provide lines that can be used to help hang and position companies' ROVs. The weight of the lines will be zeroed out before the vehicle is weighed so that the weight of the lines will not add to the weight of the ROV. Companies will be responsible for lifting their vehicles into position and attaching the lines. If the ROV, including its tether, weighs 11.0 kg or less, the company will receive +20 bonus points. If the ROV weighs between 11.01 kg and 12.0 kg, the company will receive +10 bonus points. If the ROV weighs between 12.01 kg and 14.0 kg, the company will receive +5 bonus points. An ROV weighing more than 14.0 kg will receive 0 bonus points, but will

still be allowed to compete. NOTE: The control system and 1 meter of the tether may be placed on the table below the ROV and not included in the weigh-in.

Regardless of the ROVs' weight, companies must be able to personally transport the vehicle and associated equipment to the product demonstration station and to the product presentation room. ROV systems must be capable of being safely hand launched.

Hand powered lifts and levers and tether management systems may be used with the vehicle. Hand powered lifts and levers will not count towards the size or weight of the ROV. Tether management systems that can be separated from the vehicle will not count towards the size or weight of the ROV.

Only the six designated product demonstration team members will be allowed into the on-deck circle during and after the measurement and weigh in. Once a company's vehicle has been measured and weighed, it must remain there until the company moves to its product demonstration station. Companies that detach equipment from the vehicle may not re-install that equipment until the 5-minute set up period. At that time, companies may replace any items that were detached for the measurement, but no new equipment (i.e., equipment that was not included in the size and weight measurements) may be added to the vehicle. If it is discovered that a company added equipment that was not included in the measurements, the company will not be permitted to compete in that product demonstration run.

A video showing a simulated size measurement can be found here [www.youtube.com/watch?v=YtM4pwqvDyo](http://www.youtube.com/watch?v=YtM4pwqvDyo) and <https://vimeo.com/145671423>

\*Reference: [www.nasa.gov/centers/marshall/news/background/facts/astp.html](http://www.nasa.gov/centers/marshall/news/background/facts/astp.html)

## **PRODUCTION DEMONSTRATION**

### **TASK 1: OUTER SPACE: MISSION TO EUROPA**

Your company must descend to the bottom of the ocean on Jupiter's moon Europa. Once there, your company is tasked with measuring the temperature of fluid venting from a crevice on the seafloor by inserting a temperature sensor into the flow.

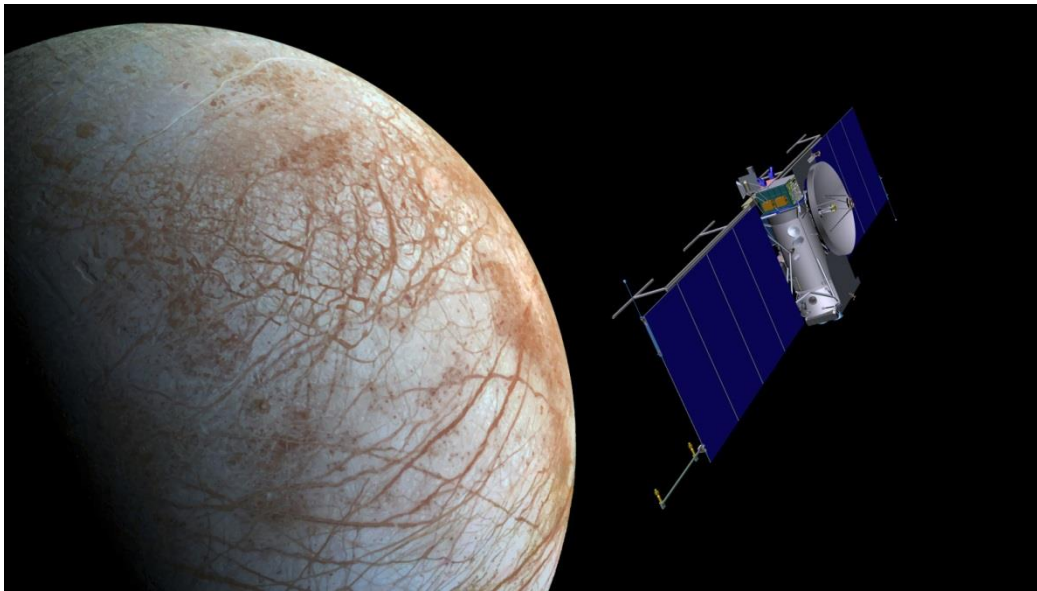

Artist concept of NASA's Europa mission spacecraft approaching its target for one of many flybys.  
Photo credit: NASA.

Your company is also tasked with determining the depth at two points: the bottom of the ice sheet and the seafloor. The distance between the surface and the bottom of the ice sheet will determine the thickness of the ice sheet. The distance between the bottom of the ice sheet and the seafloor will determine the depth of the ocean under the ice.

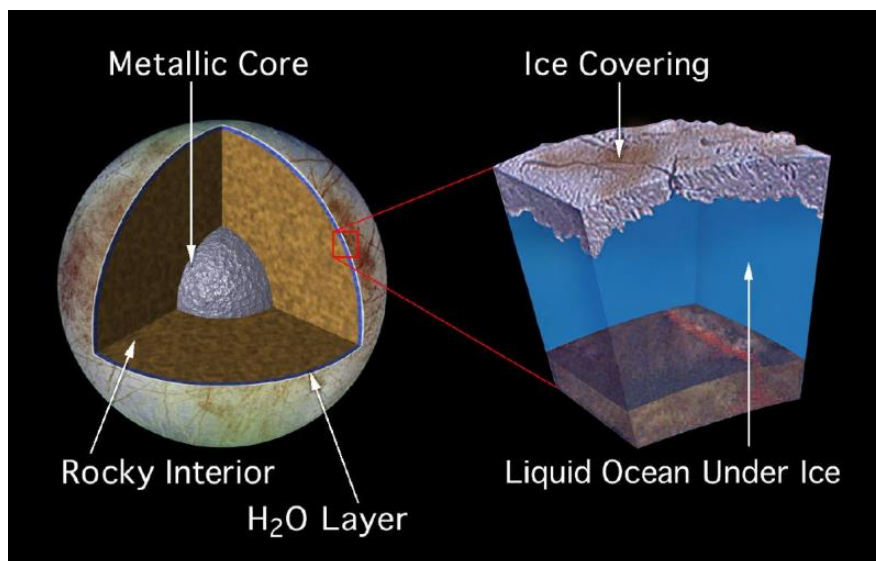

A model for the potential composition of Jupiter's moon Europa.  
Photo credit: [https://en.wikipedia.org/wiki/Europa\\_\(moon\)](https://en.wikipedia.org/wiki/Europa_(moon)).

Finally, your company must connect an Environmental Sample Processor (ESP) to the power and communications hub. Both the ESP and the power and communications hub have already been deployed on the sea floor. Your vehicle must retrieve the cable connector from the ESP's elevator and lay the cable through RANGER Class

two waypoints to simulate avoiding potentially hazardous terrain. Once the cable has been laid through the two waypoints, your vehicle must open the door on the power and communications hub, and insert the cable connector into the port on the hub.

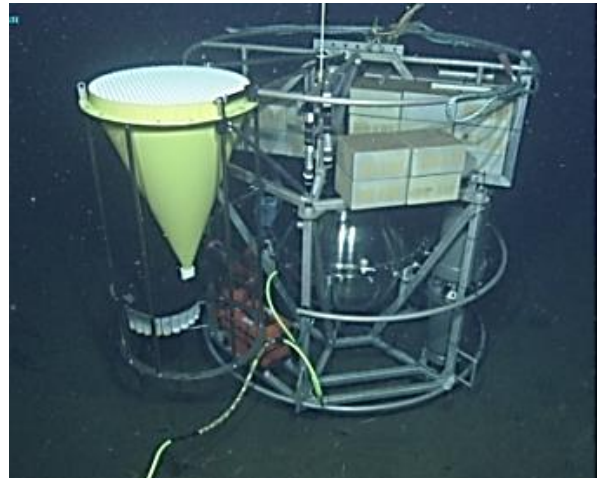
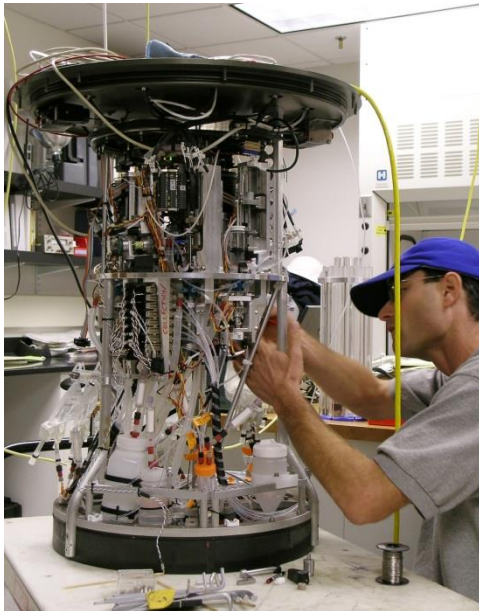

An ESP being prepared for deployment and later connected to the MARS (Monterey Accelerated Research System) cabled observatory, 900 m deep in Monterey Bay.

Photo credit: Monterey Bay Aquarium Research Institute, Moss Landing, CA.

**This task involves the following steps:**

- **Inserting the temperature sensor into the venting fluid – 10 points**
- **Measuring the temperature of the venting fluid – up to 20 points**
  - Temperature measurement is within 3°C of benchmark – 20 points
  - Temperature measurement is within 4°C of benchmark – 10 points
  - Temperature measurement is within 5°C of benchmark – 5 points
- **Determining the thickness of the ice crust – up to 10 points**
  - ≤ 10 cm from true depth – 10 points
  - > 10 cm from true depth – 0 points
- **Determining the depth of the ocean under the ice – up to 10 points**
  - ≤ 10 cm from true depth – 10 points
  - > 10 cm from true depth – 0 points
- **Connecting the ESP to the power and communications hub – up to 50 points maximum**
  - Retrieve the ESP's cable connector from the elevator – 5 points
  - Lay the ESP cable through two waypoints – 10 points each (20 points total)
  - Open the door to the port on the power and communications hub – 5 points
  - Insert the cable connector into the port on the power and communications hub – 20 points

## TOTAL POINTS = 100

### Product Demonstration Notes:

The steps of the Mission to Europa task may be done in any order with the exception of connecting the ESP to the power and communications hub. Companies must retrieve the ESP connector, lay the cable through two waypoints, open the door on the power and communications hub, and insert the connector into the port *in that order*. Companies may alternate between the steps of the Mission to Europa task and other tasks.

Companies are responsible for providing their own temperature sensor; the MATE Center will not provide one. Power for the temperature sensor must come from the surface, either independently or through the ROV; no on-board batteries of any type are allowed. Companies may use USB to connect their sensor to a computer. Companies may also use surface battery packs (limited to 12 volts maximum), or the MATE supply to provide power for their temperature sensor (independently or through the ROV). An independent battery pack must be fused with a 3 amp fast blow fuse. If companies are using the MATE supply to power a sensor, both ROV and sensor must run through the single 25 amp fuse before splitting off to the 3 amp sensor fuse. (See ELEC-001R for more information.)

The crevice will be constructed from a ¾-inch PVC pipe and a ¾-inch PVC connector that protrudes from the top of a 5-gallon bucket. A 360 GPH (gallon per hour) bilge pump will push water through the ¾-inch pipe; companies should be prepared for that flow rate. Companies will receive 10 points when they successfully insert their temperature sensor into the emerging flow. Successfully inserting the sensor means that the emerging water does not push the sensor away and out of the flow. The sensor must stay in the flow for at least 5 seconds to be considered successfully inserted.

Once the sensor is inserted, companies must measure the temperature of water emerging from the pipe. Companies must show the product demonstration judge a temperature reading in degrees Celsius. The product demonstration judge will compare the given temperature reading to the benchmark provided by a MATE Center temperature probe. Companies will receive 20 points if their reading falls within 3°C of the MATE benchmark temperature reading. The MATE Center temperature probe will be positioned approximately 4 cm down inside the ¾-inch PVC coupling.

Companies must also determine the depth at two points: the bottom of the ice sheet and the bottom of the seafloor. There will not be a real or simulated ice sheet in the pool. Rather, a horizontal line on the wall of the pool will denote the bottom of the ice sheet. A second horizontal line on the pool wall will denote the bottom of the seafloor. The line denoting the bottom of the ice sheet will be made by a horizontal, 1 meter length of ½-inch PVC pipe with a PVC cross in the middle. Both the pipe and the cross will be painted red. The line denoting the seafloor will be made by a horizontal, 1 meter length of ½-inch PVC pipe with a PVC cross in the middle. Both the pipe and the cross will be painted yellow. The official MATE depth measurement will be to the exact middle of each painted PVC cross.

Using their depth readings, companies must calculate the distance (depth) between the surface and the mark

denoting the bottom of the ice sheet. Companies will receive 10 points if their calculated depth is within 10 cm of the true depth between the surface and the mark denoting the bottom of the ice sheet. Companies must also calculate the distance (depth) between the mark denoting the bottom of the ice sheet and the mark denoting the seafloor. Companies will receive 10 points if their calculated depth is within 10 cm of the true depth between the mark denoting the bottom of the ice sheet and the mark denoting the seafloor. All depth measurements, and any calculations to obtain depths, must be shown to the product demonstration judge; companies are not allowed to guess at the depth. All depths should be given in meters, at least to the hundredths place (3.41 meters, for example).

The ESP will be secured to an elevator located on the bottom of the pool. The ESP and the elevator will be constructed of ½-inch PVC pipe. A cable connector attached to 8 meters of coiled line will also be located on the ESP elevator. The cable connector will be constructed from 1-inch PVC pipe. Both a screw hook and a screw eye will act as grab points on the cable connector, but companies may retrieve the cable connector by any method they wish. Companies will receive 5 points when the ESP cable connector is successfully retrieved. A successful retrieval of the cable connector is defined as the cable connector under control of the ROV and no longer in contact with the elevator. Knocking the cable connector off the elevator does not count as a successful retrieval; it must be under control of the ROV.

The cable connector will weigh less than 10 Newtons in water.

Two waypoints will be located in an arc between the ESP and the power and communications hub. The waypoints will be constructed of ½-inch PVC pipe in the shape of an X lying flat against pool bottom. The ends of the X will extend 20 cm from the pool bottom. The cable must be laid inside two of the vertical protrusions. Companies will receive 10 points for successfully laying the cable through each waypoint, 20 points total.



*Depiction of successful and unsuccessful cable lying through waypoints. Waypoint A is an unsuccessful cable lay, as the cable is inside one vertical protrusion only. Waypoint B is a successful cable lay, as the cable is inside two vertical protrusions. Waypoint C is an unsuccessful cable lay, as the cable is only inside one vertical protrusion (the lower right protrusion only).*

The power and communications hub will be located on the bottom of the pool. The power and communications hub will be constructed from a milk crate. The door on the hub will be constructed from flat RANGER Class

plastic sheeting and attached with hinges. A 1 cm square of Velcro will secure the door in a closed position. A ½-inch PVC pipe handle will be attached to the door. Companies may use this handle to open the door or open it by other means. Companies must open the door on the power and communications hub to access the port inside. Companies will receive 5 points when the door is successfully opened. Successfully opening the door is defined as the door pushed at least 90° from the closed position. If the door closes after a company has successfully opened it, they will not lose points. However, the company may need to reopen the door to complete the task.

Once the door is opened, companies must insert the cable connector into the port located in the power and communications hub. The port inside the hub will be constructed of 2-inch PVC pipe. The port will be positioned horizontally, i.e. it will be parallel to the pool bottom. Companies will receive 20 points when they successfully insert the cable connector into the port. A successful installation is defined as the 1-inch cross on the cable connector positioned flush against the 2-inch pipe of the port inside the power and communications hub. The cable connector must stay inside the port for 5 seconds after being released by the vehicle to count as a successful insertion.

## **TASK 2: INNER SPACE: MISSION-CRITICAL EQUIPMENT RECOVERY**

Your company is tasked with locating and recovering CubeSats that sank in the Gulf of Mexico after a recent NASA test launch. While multiple CubeSats were launched, only four mission-critical CubeSats need to be recovered for engineering analysis. Using the serial numbers provided, your company must locate these four CubeSats, recover them, and place them in a collection basket to be brought to the surface by NASA personnel at a later time.



CubeSats undergo final inspection at NASA Ames Research Center in Moffett Field, California.

Photo Credit: NASA, Dominic Hart.

**This task involves the following steps:**



- **Finding and identifying the serial numbers of the four mission-critical CubeSats – 5 points each (20 points total).**
- **Recovering the four mission-critical CubeSats and placing them in a collection basket – 5 points each (20 points total).**

**Total points = 40**

**Product Demonstration Notes:**

Companies must see the serial numbers on the CubeSats and verify that they match the mission-critical serial numbers before recovering and placing the CubeSats in the collection basket. Only the four CubeSats that match the mission-critical serial numbers may be placed on the collection basket.

Companies may complete the steps of the Mission-Critical Equipment Recovery task in any order. Companies may alternate between the steps of the Mission-Critical Equipment Recovery task and other tasks.

Eight CubeSats will be located on the bottom of the pool. The CubeSats will be constructed from ½-inch PVC pipe shaped into a square prism. Corrugated plastic sheeting will be attached to two sides of the CubeSats. One side of the corrugated plastic sheeting will have the serial number printed on it in 2-inch, black on white lettering.

Companies will receive the serial numbers of the four mission-critical CubeSats during the 5-minute set-up time. All eight CubeSats will be positioned so the serial number is facing downwards and flush against the bottom of the pool. Companies will need to lift or reposition the CubeSats so the serial number can be seen through a video camera. Companies will receive 5 points when they find one of the mission-critical serial numbers, 20 points total. Companies must show the product demonstration judge the serial number on a video display. The serial number may be upside down or sideways, but the judge must be able to verify that it is one of the mission-critical serial numbers.

Once a mission-critical serial number is found, companies must recover the CubeSat and place it into the collection basket. The collection basket will be constructed from a 75 cm x 75 cm square of ½-inch PVC pipe. A 2 meter length of rope will be attached to each corner of the PVC square. These four lengths of rope will come together at a float positioned above the collection basket. Companies will receive 5 points for each CubeSat placed into the collection basket, 20 points total. To receive points, the CubeSat must be entirely within the ½-inch PVC square. No portion of the CubeSat may be on top of or outside the PVC square.

Only the four mission-critical CubeSats may be placed in the collection basket. If a company places a non-mission-critical CubeSat in the basket, they will be penalized 5 points for each non-critical CubeSat placed in the basket.

RANGER class CubeSats will weigh less than 15 Newtons in water.

Note: The task is complete when all four mission-critical CubeSats are placed within the collection basket. Companies do not have to return the CubeSats or the collection basket to the surface.

### **TASK 3: INNER SPACE: FORENSIC FINGERPRINTING**

Your company must collect a sample from two different oil mats located on the seafloor and return them to the surface. Once at the surface, your company must analyze a gas chromatograph – or “fingerprint” – of each sample to determine the oil’s origin.



An oil mat around a natural seep on the sea floor.

Photo credit: [www.newenergyandfuel.com](http://www.newenergyandfuel.com).

**This task involves the following steps:**

- **Collecting one sample of two oil mats on the seafloor – 5 points each (10 points total)**
- **Returning the samples to the surface – 5 points each (10 points total).**
- **Analyzing a gas chromatograph of each sample to determine the oil’s origin – 10 points each (20 points total).**

**Total points = 40**

#### **Product Demonstration Notes:**

The steps of the Forensic Fingerprinting task may be done in any order. Companies may alternate between the steps of the Forensic Fingerprinting task and other tasks.

Two oil “mats” will be located on the bottom of the pool. The mats will be simulated by a 5-gallon bucket lid with 4 individual samples on each lid. Oil samples will be constructed from a 1-inch PVC tee and end caps.

One oil mat and its four oil samples will be painted black. One oil mat and its four oil samples will be painted brown. Companies must collect one sample of oil from each mat and return it to the surface. Companies will receive 5 points for each oil sample collected, 10 points total. Collecting an oil sample is defined as having the oil sample under control of the vehicle and no longer in contact with the bucket lid or the bottom of the pool. If a company drops an oil sample after it has been successfully collected, the company will not lose points for the collection. However, the company must retrieve the dropped oil sample, or a different oil sample, to continue the task. Once collected, the oil samples must be returned to the surface, side of the pool. Companies will receive 5 points for each oil sample returned to the surface and placed on the pool deck, 10 points total.

Once an oil sample is at the surface, companies can retrieve the oil's gas chromatograph, or fingerprint. The gas chromatograph will be printed on a laminated sheet and rolled up inside the 1-inch pipe of the sample. Companies must compare the sample's fingerprint to fingerprints of samples of known origins to determine its origin.

A handbook of fingerprints of oil samples from known origins will be provided at each product demonstration station, although companies may choose to print and bring their own handbook. To successfully determine the origin of an oil sample, companies must compare the sample's fingerprint to one of the known oil fingerprints and find a match. Note: Keep in mind that oil will "weather;" that is, its chemical composition will become modified by a wide variety of physical, chemical, and biological processes. Therefore, the sample's fingerprint may not match identically to the fingerprints of known origins.

Companies must determine the origin of each oil sample and report their findings to the product demonstration judges during the 15 minute product demonstration run. Companies will receive 10 points when they successfully determine each oil sample's origin, 20 points total. If a company incorrectly identifies the origin of an oil sample, they may not re-analyze the gas chromatograph and try again. Companies may not guess at the origin if they have not retrieved an oil sample.

RANGER class companies' oil fingerprint handbook will contain gas chromatographs of four known samples.

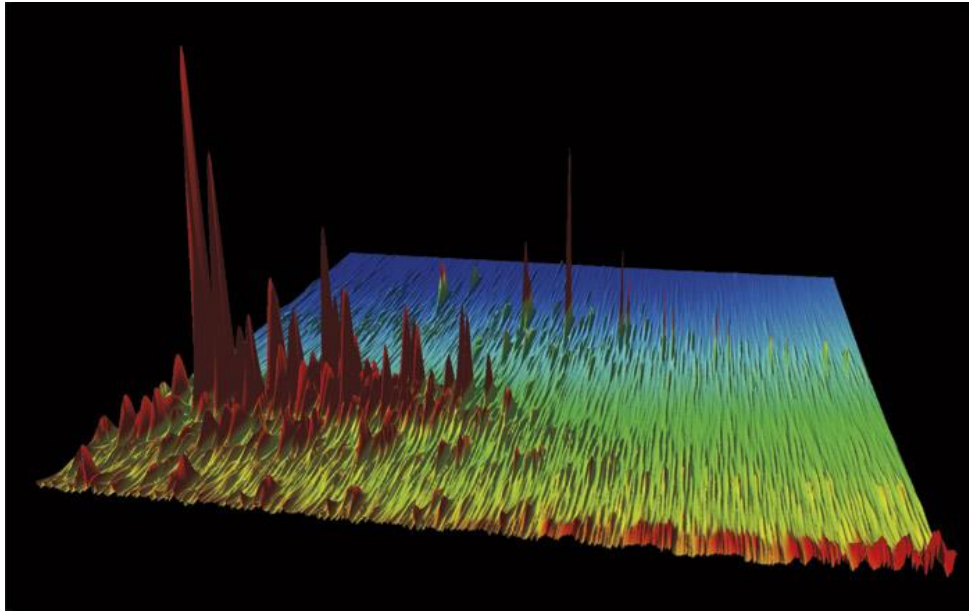

A 3-D chromatogram of oil that leaked from the Macondo well during the Deepwater Horizon oil spill. Each peak represents one of thousands of individual chemical compounds in the oil. The taller the peak, the more of that particular compound is in the oil.

Photo credit: Bob Nelson, Woods Hole Oceanographic Institution, and the Deep-C Consortium (<http://deep-c.org/>).

#### **TASK 4: INNER SPACE: DEEPWATER CORAL STUDY**

Your company must survey two colonies of *Paramuricea biscaya*, a deepwater coral found in the Gulf of Mexico. Surveying the corals involves photographing each specific colony and comparing the photo to previous photos of the same colony. Your company must then evaluate whether the coral colony is growing, stable, or decreasing in size. Your company is also tasked with collecting and returning to the surface two colonies of a different coral species, the scleractinian coral *Madrepora prolifera*, for laboratory analysis.

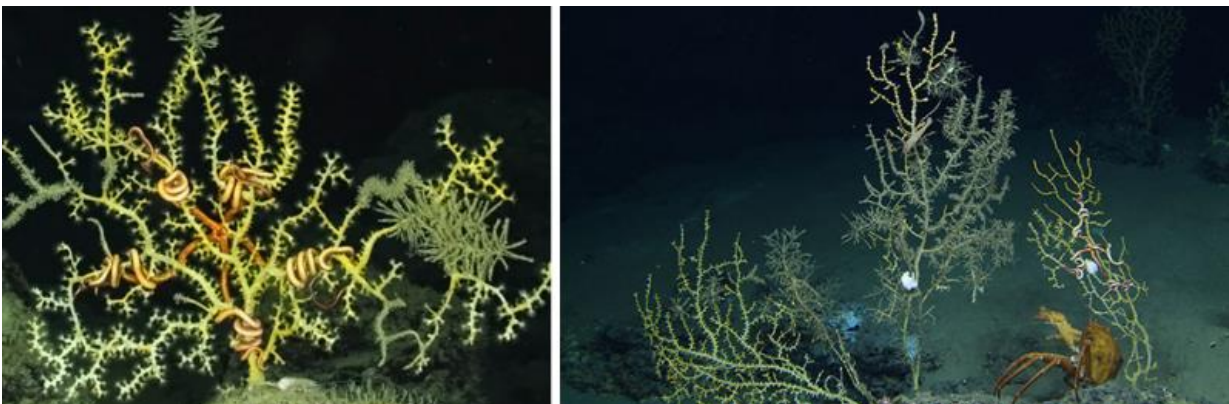

Paramuricid corals from the Gulf of Mexico.

Photo credit: Chuck Fisher, Pennsylvania State University

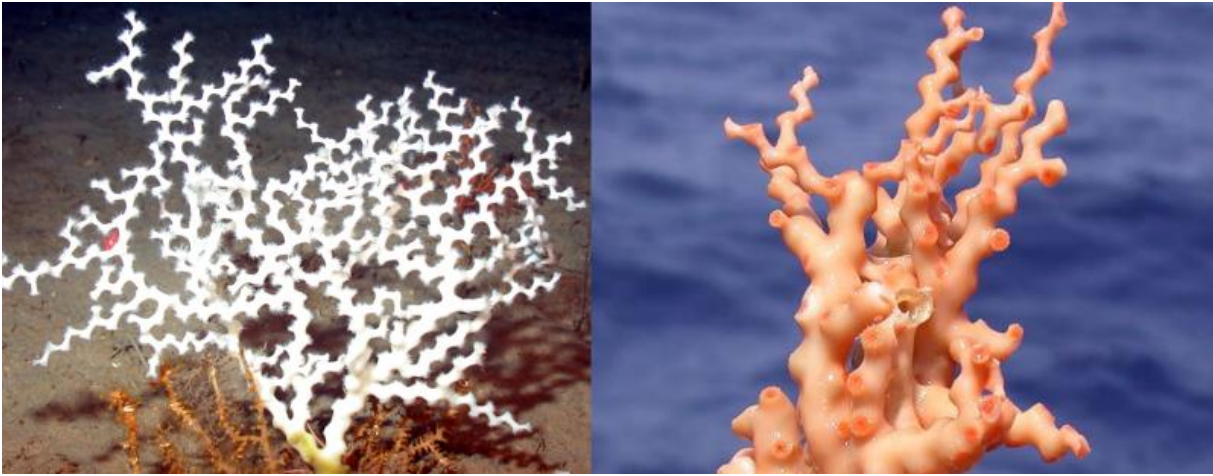

Madrepora corals from the Gulf of Mexico.

Photo credit: left, [https://en.wikipedia.org/wiki/Madrepora\\_oculata](https://en.wikipedia.org/wiki/Madrepora_oculata); right, [https://en.wikipedia.org/wiki/Deep-water\\_coral](https://en.wikipedia.org/wiki/Deep-water_coral).

**This task involves the following steps:**

- **Photographing two coral colonies – 5 points each (10 points total)**
- **Comparing the photos to photos from previous years to assess their condition – 5 points each (10 points total).**
- **Returning two coral samples to the surface – 5 points each (10 points total)**

**Total points = 30**

**Product Demonstration Notes:**

The steps of the Deepwater Coral Study task may be done in any order, although companies must photograph each coral before comparing the photos to photos from previous years. Companies may alternate between the steps of the Deepwater Coral Study task and other tasks.

Two *Paramuricea biscaya* coral colonies will be located on the bottom of the pool. *Paramuricea biscaya* coral colonies will be constructed from ½-inch PVC pipe. The colonies will be labeled **A, B, C, or D** using black on white 3-inch lettering set onto a flat black plastic sheet. Companies will receive 5 points when they photograph each coral colony, 10 points total. The photograph must be a still image, not a video, that includes the entire coral colony and the 3-inch letter. The still image can be a digital screen shot, hard copy print-out, or other format. A still image captured from a video is acceptable. A still image taken by a cell phone or tablet of the video screen is acceptable as well. The cell phone/tablet taking the photograph of the coral colony will not count against the video display limit for RANGER teams (see [3.8.2 Displays](#)). Companies must show the photograph to the product demonstration judge in order to receive points.

Once a coral colony has been photographed, companies must compare the photograph to a photograph taken 12 months before. Previous photographs of each of the two coral colonies will be included in a handbook at the product demonstration station. The previous photographs will include the entire coral colony and the 3-

inch letter. Companies must compare photographs to assess whether the coral has grown, is stable, or has decreased in size. A coral colony that is growing will have 1) additional branches or 2) colored branches that were black in the previous photograph. A coral colony that is stable will have the same number and color of branches as in the previous photo. A coral colony that is decreasing in size will have 1) fewer branches or 2) black branches that were another color in the previous photo.

Companies must report to the product demonstration judge whether each of the two coral colonies is growing, stable, or has decreased in size during the 15 minute product demonstration period. Companies may not guess; they should provide their reasoning to the station judge. Companies will receive 5 points for each successful assessment of the coral colony, 10 points total. If a company's assessment is incorrect, they cannot go back and attempt to reassess the coral colony.

*Paramuricea biscaya* coral colonies are fragile and should not be touched by either an ROV or its tether. If at any point during the product demonstration, an ROV or tether touches a *Paramuricea biscaya* coral colony, companies will receive a 5 point penalty. Multiple infractions will incur multiple penalties, up to two penalties per coral colony, 4 penalties total (-20 points).

Companies must also collect a different species of coral, the scleractinian coral *Madrepora prolifera*. *Madrepora prolifera* coral colonies will be constructed out of red, brown and pink chenille pipe cleaners mounted into a PVC base. Companies will receive 5 points for each *Madrepora prolifera* coral colony they return to the surface, 10 points total. Companies will not be penalized for touching or impacting *Madrepora prolifera* coral colonies.

#### **TASK 5: INNER SPACE: RIGS TO REEFS**

An oil platform in the Gulf of Mexico's Green Canyon lease block #272 no longer produces enough oil to make it economically feasible to continue drilling operations. The plan is to decommission the platform and turn it into an artificial reef. Before removing the top of the platform and converting the base into an artificial reef habitat, the oil well must be capped.



An artificial reef created from an obsolete oil and gas platform in the Gulf of Mexico.  
Photo credit: State of Louisiana, Department of Wildlife and Fisheries, Artificial Reef Program.

Your company is tasked with securing a cap to the wellhead. This task involves installing a flange on top of the wellhead, securing the flange with a bolt, installing a cap onto the flange, and securing the cap with bolts.

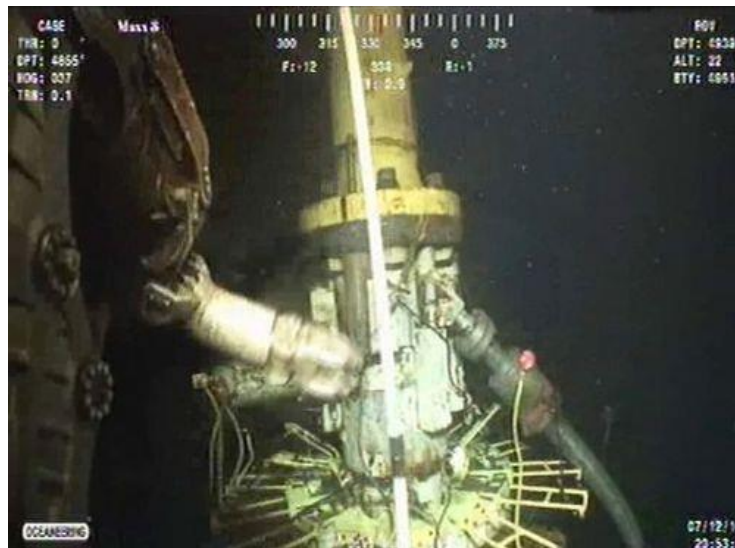

An ROV placing a cap on a wellhead.  
Photo Credit: Oceaneering International.

**This task involves the following steps:**

- **Installing a flange to the top of the wellhead – 10 points**
- **Securing the flange to the wellhead with one bolt – 10 points**
- **Installing a wellhead cap over the flange – 10 points**
- **Securing the cap to the flange with two bolts – 10 points each, 20 points total**

**Product Demonstration Notes:**

RANGER Class

The steps of the Rigs to Reef task must be done in order. The bolt must be inserted into the flange before the cap can be installed. If companies cannot complete a step of this product demonstration, they cannot skip steps and continue. Companies may alternate between the steps of the Rigs to Reefs task and other product demonstrations.

At the competition, the flange, wellhead cap, and all the bolts will be located on an elevator on the bottom of the pool. The elevator will be within 1 meter of the base of the wellhead. Note: This elevator will be specific to this task; it will not be the same as the elevator used in the Mission to Europa product demonstration.

Companies are not permitted to pre-install bolts into the flange or wellhead cap while those components are on the elevator. Only when the flange is installed may the bolts be inserted into the holes to secure it. Only when the wellhead cap is installed can the bolts be inserted into the ports to secure the cap to the flange.

Companies must attach the flange to the top of the wellhead. The wellhead will be constructed of a cement base with a 2-inch wellhead. At the top, the size of the wellhead will decrease to 1 ¼-inch PVC pipe. The top of the wellhead will be 60 cm to 1.25 meters above the pool bottom. The flange will be constructed of a 3-inch to 2-inch ABS reducer bushing. A length of 1/8-inch rope will serve as a grab point for the flange.

Companies must attach the flange over the top of the wellhead. The flange must sit flush against the 2-inch to 1 ¼-inch lip on the wellhead. The flange must be oriented so the Velcro side is facing upwards. Companies will receive 10 points when they have attached the flange to the top of the wellhead.

Once a flange is installed, it must be secured with one bolt. Bolts will be constructed from a ½-inch PVC tee and a bolt covered in Velcro loops. The flange will have six holes. Companies may insert the bolt into any of the six holes. The final 5 cm of the 1 ¼-inch cut wellhead pipe will be covered with Velcro hooks. The ends of the bolts will be covered with Velcro loops. The Velcro connection will secure the bolt into the holes and secure the flange onto the pipe. Companies will receive 10 points when the bolt successfully secures the flange. A successful installation is defined as the bolt staying in the hole on the flange when the ROV releases it. If the bolt falls out of the flange, it must be re-installed in order to receive 10 points.

Companies must install the cap onto the flange. The cap will be constructed from a 3-inch to 2-inch ABS reducer bushing. A length of 1/8-inch rope will serve as a grab point for the cap. Two ½-inch end caps are attached to the top of the bushing. The cap must be oriented so the Velcro side is facing downwards and the end caps are facing upwards. Companies will receive 10 points for successfully installing the cap. A successful cap installation is defined as bottom of the cap sitting flush against the top of the flange.

The bolt securing the flange to the pipe must stay in place when the cap is installed. If the bolt falls out of the flange when the cap is inserted, companies must re-insert the bolt into the flange before they can receive points for installing the cap.

Once the cap has been installed, it must be secured by inserting two bolts into the ports on top of the cap. The ports are constructed of ½-inch end caps with Velcro on the inside of the cap. Companies will receive 10



points for each bolt that is successfully installed into the ports on the top of the cap, 20 points total. A successful installation is defined as the bolt staying in the end cap port when the ROV releases it. If a bolt falls out of the cap, it must be re-installed in order to receive 10 points.

Any product demonstration items dropped from the vehicle to the pool bottom (flange, cap, bolts) will not count as penalty debris. All three bolts must remain secured in place for 5 seconds after completion of the Rigs to Reefs product demonstration task in order to retain full points.

### **TIME BONUS**

If a company has successfully completed all five product demonstration tasks and is returning to the surface with corals, the product demonstration time will stop when a member of the company touches the vehicle. Corals on board may be detached and set on the pool deck after the clock has stopped. If a coral is subsequently dropped from the vehicle, the company will not receive points for returning the coral, time will not restart, and the company will not receive a time bonus. Note: Oil samples must be analyzed during the product demonstration period. If the ROV returns the samples to the surface at the end of the run, the time will stop when the samples have been analyzed and the results given to the Product Demonstration judge. In this case, the time does not stop when a company member touches the ROV.

### **PRODUCT DEMONSTRATION RESOURCES**

The [RANGER Oil Fingerprint Handbook](#) contains gas chromatographs of oil samples from four locations.

The [RANGER Coral Colony Handbook](#) contains previous photos of each coral colony.

The [RANGER Product Demonstration Photos](#) contains photos of completed product demonstration props. The RANGER product demonstration photos will include example photos of coral colonies that are growing, stable, and decreasing in size.

See the [RANGER Product Demonstration SolidWorks](#) files for CAD representations of the product demonstrations.

## **PART 2: PRODUCT DEMONSTRATION PROP BUILDING INSTRUCTIONS & PHOTOS**

By popular request, this section has been removed and made into its own, separate document. This document will be released and posted by December 4<sup>th</sup>, 2015.

## PART 3: VEHICLE DESIGN & BUILDING SPECIFICATIONS

### 1.0 GENERAL

Questions about vehicle design and building specifications, as well as competition rules, should be posted to Competition Help within the [MATE Forum Hub \(www.marinetech.org/forums/\)](http://www.marinetech.org/forums/). This ensures that all companies can view the questions and answers and helps to avoid duplicate questions. That said, companies should make sure that their questions have not already been asked – and answered – before posting. When posting their question, companies should reference the specific specification (e.g. ELEC-002E).

#### 1.1 Glossary and Acronyms

<b>ANSI</b>	American National Standards Institute
<b>Company</b>	Teams providing a ROV System for evaluation purposes
<b>HD</b>	High-Definition
<b>IEC</b>	International Electrotechnical Commission
<b>Instrument</b>	A device that contains one or more sensors and a method for converting the information from the sensor into a transmittable and storable form
<b>NEMA</b>	National Electrical Manufacturers Association
<b>LARS</b>	Launch and Recovery System
<b>Operate</b>	Correctly performing designed functionality
<b>PWM</b>	Pulse Width Modulation, a method to electronically vary the effective voltage delivered to an electrical load.
<b>SID</b>	System Interconnection Diagram

#### 1.2 Conventions

All values contained in this document are threshold values unless specifically stated otherwise. All water depths are given in meters (m). All dimensions and measurements utilize SI units.

#### 1.3 Documentation Required

As part of the [Technical Documentation](#), the following SIDs are required. All diagrams must be drawn with a CAD (computer assisted drawing) program. Hand drawn figures are not permitted. All symbols must be standard symbols as specified by ANSI, NEMA, or IEC.

DOC-001: SID Electrical: One figure must be an electrical diagram for all the systems above the waterline. This diagram should show the ROV system fuse, controls, and tether connections. A second figure should be an electrical diagram showing the ROV sub-systems and their connections. Both diagrams should not exceed one page in length. The diagrams must not be component level schematics, but a higher level interconnection block type diagram. Do not include individual pins on a board; this is intended to be a higher level diagram. An example of these diagrams is an Electrical One Line Diagram. Examples of acceptable SIDs can be found

here:

- [www.marinetech.org/files/marine/files/ROV%20Competition/International%20Competition/2014%20tech%20reports/EXPLORER/EXPLORER/Memorial%20University/EER\\_Memorial\\_University\\_Newfoundland\\_Tech\\_Report\\_Final\\_2014.pdf](http://www.marinetech.org/files/marine/files/ROV%20Competition/International%20Competition/2014%20tech%20reports/EXPLORER/EXPLORER/Memorial%20University/EER_Memorial_University_Newfoundland_Tech_Report_Final_2014.pdf), page 22
- [www.marinetech.org/files/marine/files/ROV%20Competition/International%20Competition/2014%20tech%20reports/RANGER/RANGER/Cornerstone%20Academy/Cornerstone\\_Academy\\_Tech\\_Report\\_Final.pdf](http://www.marinetech.org/files/marine/files/ROV%20Competition/International%20Competition/2014%20tech%20reports/RANGER/RANGER/Cornerstone%20Academy/Cornerstone_Academy_Tech_Report_Final.pdf), page 21



DOC-002: SID Fluid Power: If a company is using fluid power, fluid power diagrams must be provided. The first figure must document the components on the surface. The second figure must document the components located onboard the ROV.





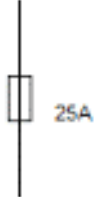

DOC-003: Independent Sensor Devices: If a company is utilizing an independent sensor device that will be installed and released by the ROV, a SID must be included for this device. This diagram must be completed to the specifications listed in DOC-001.

DOC-004: All required documentation sent to the MATE Center MUST be in searchable PDF format (see <https://fd4686477cb19f983f54-68abf00cbc1a2cc111562c013cb867db.ssl.cf1.rackcdn.com/SearchablePDFs.pdf> for information about creating searchable PDFs.

DOC-005: All symbols used in documentation must be in ANSI, NEMA or IEC format.

DOC-006: The following ANSI and IEC symbols are all acceptable for MATE required documentation.

Item	ANSI	IEC
FUSE		
CIRCUIT BREAKER		

SWITCH	 NO SWITCH	 NC SWITCH	 SPDT SWITCH	
RELAY CONTACT	 NC RELAY	 NO RELAY	 NC RELAY	

## 2.0 SAFETY

Safety is the competition's primary concern and guiding principle. Any system that is deemed unsafe by competition officials will not be allowed to compete. If a safety concern is identified during the initial inspection, companies are permitted to modify their system and have it re-inspected. Companies are permitted to have their vehicle re-inspected twice. If a company fails to pass its third and final safety inspection, it is disqualified from the underwater competition portion of the event. There are NO APPEALS once an ROV has been disqualified.

### Examples of safety violations from previous ROV competitions include:

- The electrical SID included in the technical documentation did not show a main fuse or circuit breaker.
- The ROV used pneumatics, but the technical documentation did not include a pneumatics diagram.
- The ROV used pneumatics, but the company had not passed the fluid power quiz two weeks prior to the competition.

### 2.1 Safety Instruction & Observation Program and HSE Awards

The **Safety Instruction & Observation Program** is being coordinated by [Oceaneering International](#). Companies earn points towards a Health, Safety, and Environmental (HSE) Award through this program. (Visit [www.youtube.com/watch?v=nK-meCuLAhY](http://www.youtube.com/watch?v=nK-meCuLAhY) for a description of the safety inspection protocol used at the international competition and Oceaneering's safety inspection program.)

Each member of the company is encouraged to read [Oceaneering Americas Region HSE Employee Handbook](#), with emphasis placed on the following chapters.

Chapter 1 - Housekeeping

Chapter 9 - Hand Safety

Chapter 11 - Lifting and back safety

Chapter 12 - PPE

RANGER Class

Chapter 17 - Tool Safety  
Chapter 24 Electrical Safety  
Chapter 29 - Employee Observation Program  
Chapter 33 - JSEA  
Chapter 37 - Working at Other sights

### **Job Site Safety Analysis (JSAs)**

For companies advancing to the international competition, 5 additional points can be earned by creating a JSA and submitting it 1) along with the [Technical Documentation](#) and 2) to the Product Demonstration judge when entering the product demonstration station.

Regionals may or may not offer points for JSAs. Contact your [regional coordinator](#) for more information.

A **JSA** describes job tasks in step-by-step fashion, identifies associated hazards at each step, and outlines proper hazard controls that minimize the risk of injury or illness to the individual(s) performing that task. JSAs are used extensively by the offshore industry.

For more information and examples, companies can visit the following web sites:

- <http://ehs.berkeley.edu/how-do-i-write-and-update-job-safety-analysis-jsa>
- [www.safetyworksmaine.com/safe\\_workplace/safety\\_management/hazard\\_analysis.html](http://www.safetyworksmaine.com/safe_workplace/safety_management/hazard_analysis.html)

**POTENTIAL HAZARDS**

DESCRIBE JOB STEP <small>(List the natural steps of the job. Do not make the steps too broad or too fine)</small>	POTENTIAL HAZARDS <small>(What are the potential hazards identified at this part of the job steps)</small>	RECOMMEND RISK CONTROL MEASURES <small>(describe how the identified hazards can be eliminated or reduced)</small>	RESPONSIBLE PERSON (S) <small>(Implementing control)</small>	INITIAL <small>(Of the responsible person/s)</small>
Toolbox Talk	Miscommunication	<p><b>ANYONE can call ALL STOP at any point if an unsafe condition /act is perceived/observed.</b></p> <p><b>Cell phone use is PROHIBITED in test area while testing!</b></p> <p>Ensure all participants are aware of procedures and roles within the procedure and sign JSEA acknowledging thusly.</p> <p>Ensure that all participants are wearing correct PPE (safety glasses, safety shoes, gloves, and hard hats if crane ops are being performed)</p> <p>Ensure participants/witnesses are wearing adequate clothing for weather conditions and to take breaks whenever necessary.</p>		
Hydraulic Function Testing	<p>Stored/Trapped Energy: Up to <b>12,000 PSI</b></p> <p>Environmental Discharge</p> <p>Tubing/Hose Failure</p> <p>Line of Fire</p>	<p>Ensure all functions have pressure/flow reduced to 0 PSI when not being actively function tested.</p> <p>Ensure each circuit is setup correctly before increasing pressure.</p> <p>Ensure Vent hoses are properly connected to fluid containment reservoir.</p> <p>Ensure all hoses are whip checked before coming up on pressure.</p> <p>Ensure valves and actuators are in proper configuration before testing.</p> <p>Ensure relief valves are set to relieve at the proper setting.</p>		

Example JSA task items courtesy of Oceaneering International

**Observation Program**

The observation portion of the **Safety Instruction & Observation Program** will be implemented by Oceaneering International at the international competition.

During the event, companies may be approached at any time by MATE staff/judges/safety officers and asked questions about the HSE handbook or to address concerns about company’s utilization of proper personal protective equipment, operation, or housekeeping.

A company’s responses will be noted and scored on an observation card. A response viewed as safety compliant will receive 5 points; responses viewed as a safety violation will receive negative 5 points. No points will be awarded for responses viewed as marginal. Cards will have a signature block for the company CEO and the MATE observer; the observer retains the cards once signed. The HSE awards will be based on these and on companies’ total, overall safety points.

**NOTE:** Observations and scores are not subject to debate, including with the Chief Judge. There is no debating safety.

## 2.2 Safety Pre-inspection

Companies MUST submit their company spec sheets and SIDs to their [regional coordinator](#) two weeks before their regional competition. Contact the coordinator to determine the proper format for submission.

Once received, safety inspectors will review companies' spec sheets, SIDs, and/or technical documentation to identify potential safety violations. Companies with violations will be notified via e-mail. Once notified, companies must:

- a. Respond acknowledging receipt.
- b. Layout a plan to address the violation.
- c. Submit new documentation if required.

Those RANGER companies advancing to the international competition must submit their company spec sheets and SIDs to the MATE Center along with their technical documentation by May 26<sup>th</sup>, 2016. Note: A separate SID must be submitted even though a SID is included in the technical documentation. All documents must be submitted via:

- Dropbox. Teams can upload their files to a Dropbox folder and share that folder with the [MATE Center \(jzande@marinetech.org\)](#); OR
- Google Drive. Teams can upload their files to Google Drive and share the file with the [MATE Center \(jzande@marinetech.org\)](#).

International competition safety inspectors will review companies' spec sheets, SIDs, and technical documentation, compile a list of the safety violations, and publish them to the competition web site. This is not done to "call out" or embarrass companies in any way. It is to emphasize the fact that EVERYONE is responsible and accountable for ensuring a safe, successful event.

### **NEW in 2016!!! Penalty points**

Five points will be subtracted from the safety inspection points (see below) if:

- Companies do NOT submit the company spec sheet and SID two weeks before their regional event or 4 weeks before the international competition.
- The SID does not show a fuse or a fuse that does not use an ANSI, NEMA or IEC symbol.
- The vehicle uses fluid power, but a fluid power diagram is not included.
- The company spec sheet and technical documentation is not submitted in a searchable PDF format.
- Technical documentation over 8MB in size.
- Fuse calculations are not shown on the SID.

## 2.3 Safety Inspection

Companies must complete their safety inspection before their vehicles enter the water.

Companies advancing to the international competition must complete their initial safety inspection on the first day of the competition. Companies will be assigned to a safety inspector(s). The inspector will reference the list of violations as he/she conducts the safety inspection of the vehicle using the safety inspection sheet.

What follows is the safety inspection protocol used at the international competition. Consult your [regional coordinator](#) for more information about the safety inspection process used at your regional.

## 2.4 Safety inspection protocol

1. Before entering the water for practice or a product demonstration run, the ROV system **must** go through a safety inspection. Once the company successfully passes inspection, they will turn in their safety inspection sheet and be presented with a Green PASSED Flag. Companies must present the Green PASSED Flag to the pool practice/product demonstration coordinator before their vehicles are permitted to enter the water. Each company's flag will be uniquely identified with company number on the flag.
2. Competition staff will conduct a safety inspection of the vehicle using the [safety inspection sheet](#).
3. If the safety inspector(s) identify a safety violation, companies will have the opportunity to address it. The pool practice or product demonstration run schedule will NOT change to allow companies more time.
4. If during the second safety review the
  - a. violation has not been properly addressed or
  - b. another violation is revealedcompanies will have ONE additional opportunity to address the issue.
5. If during the third safety review a violation still exists, companies will not be permitted to participate in the underwater product demonstration component of the competition. However, companies can still participate in the engineering and communication (technical documentation, product presentation, and marketing display) component.
6. Reminder: All companies must present the Green PASSED Flag to the pool practice or product demonstration coordinator before placing their vehicles in the water. In addition, product demonstration station judges and competition officials can pause or stop a product demonstration run at any time if they feel that there is a potential safety concern.
7. **IMPORTANT NOTE:** Any company that has not passed its safety inspection before its scheduled product presentation should proceed to its presentation room/location, inform the judges of the situation, and deliver its presentation. Once the company has passed its safety inspection, it should return to its presentation room and present the judges with its signed safety checklist.

## 2.5 Safety Inspection Points

The safety inspection is worth 30 points. Each time a company fails its safety inspection it loses 10 points. After a company fails its second inspection, it must meet with the chief safety inspector to discuss a plan of action prior to returning to its workstation. THREE STRIKES and a company

- a. receives 0 points for the safety inspection and
- b. is disqualified from the underwater product demonstration component.



## 3.0 SPECIFICATIONS

The ROV system (or “system”) must meet the following requirements:

### 3.1 Operational

#### 3.1.1 Multiple Vehicles

OPER-001: MULTIPLE VEHICLES ARE NOT PERMITTED. Companies are required to design and build ONE ROV that can complete the necessary product demonstration tasks. “Floating eyeballs” or other vehicles that are not hard connected to the frame of the main vehicle are NOT permitted. Cameras designed to provide a “birds-eye view” are permitted provided that these cameras are hard connected to the frame of the main vehicle. “Hard connection” does not include the wiring between the camera and the ROV.

#### 3.1.2 Environmental

OPER-002: The ROV system must be able to function in fresh, chlorinated water with temperatures between 15°C and 30°C. Water emerging from the vent in Task #1 may be colder than 15°C. The water should be considered conducive of electrical currents.

OPER-003: The pool will not be covered or purposefully darkened in any way, although the specific product demonstration tasks may require that your ROV operates in low-light.

OPER-004: No water currents will be intentionally created. However, depending on the venue, pressurized pool filtration system outlets may cause unexpected currents.

OPER-005: The pool venue at the international competition has a flat bottom. The wall of the product demonstration area may contain small pipes or other small equipment. Companies must be prepared to avoid any of these objects.

**Note:** Regional competitions may be held in pool venues with different environmental conditions than those listed here. If you are unfamiliar with the regional pool, contact the [regional coordinator](#) in your area.

#### 3.1.3 Service Requirement

OPER-006: Companies shall provide a crew of at least 3 but not more than 6 people on the pool deck to operate the ROV System. Companies can send a larger crew complement, but no more than six can be on the deck at any time. More information about this “product demonstration team” is provided in the [COMPETITION RULES](#).

### ***3.1.4 Calibration Requirement***

OPER-007: All measurement devices shall be calibrated according to manufacturer recommended calibration procedure and performed by company members only. Company mentors or advisors are not permitted to perform calibration procedures. More information about mentor restrictions is provided in the [COMPETITION RULES](#).

### ***3.1.5 Maintenance***

OPER-008: System maintenance during field operations shall be conducted by ROV personnel at their workstations. Work of any kind must not be done by company mentors or advisors. All maintenance parts and equipment necessary to meet the operation requirements shall be provided by the company. More information about these regulations is provided in the [COMPETITION RULES](#).

## **3.2 Mechanical/Physical**

This section of the document provides specifications for the mechanical properties of the ROV system.

### ***3.2.1 Materials***

MECH-001: Any electronics housings on the ROV shall be capable of operating to depths of 7 meters.

### ***3.2.2 Size and weight***

MECH-002: ROVs are limited to a maximum diameter of 75 cm. Vehicles above this size will not be allowed to compete. Companies must be able to personally transport the vehicle and associated equipment to the product demonstration station and to the product presentation room. ROV systems must be capable of being safely hand launched. Additional points will be given to smaller, lighter vehicles (see [Size and Weight Restrictions](#)).

### ***3.2.3 Tether Length***

MECH-003E: At the international competition, ROVs must be capable of operating in a maximum pool depth of 4.8 meters (15 feet). All underwater product demonstrations will take place within 8 meters from the side of the pool. The product demonstration station will be no more than 3 meters from the side of the pool. Tether length should be calculated accordingly. Regional competitions may be held in pool venues with different maximum depths than those listed here. If you are unfamiliar with the regional pool, contact the [regional coordinator](#) in your area.

### ***3.2.4 Vehicle Deployment and Recovery***

MECH-004: The ROV system must be launched and recovered manually; no powered winches or portable cranes can be used. Hand-powered lifts and levers may be used to launch and recover the vehicle. The vehicle and any associated equipment must not damage any part of the pool or pool deck.

MECH-005: Any hand-powered lift or levers that are used as a LARS must be detailed in the technical documentation and must be part of the safety inspection procedure. Any LARS equipment that is deemed as unsafe at the safety inspection will not be allowed. Ladders, tripods, or other bracing equipment are not permitted as part of a LARS.

### 3.2.5 Propellers

MECH-006: **Propellers must be shrouded.** ROVs that have propellers exposed will not pass the safety inspection and will not be allowed to compete. A shroud must completely encircle the propeller and extend at least 2 cm in front of and behind the propeller.

## 3.3 Electrical

ELEC-001: All power provided to the ROV system through an external connection for any purpose during the competition must be obtained from the MATE competition power supply. This includes dedicated lines for cameras, manipulators, and any other devices. This is a singular point of connection; all power to the ROV must pass through the MATE-provided fuse AND the single in-line fuse or circuit breaker as specified in this section.

The exception to this rule is an independent sensor. If a MATE Center task allows an independent sensor, that sensor may be powered by other means. Sensors that are independent of the vehicle must be powered from the surface; no onboard batteries of any type are allowed. Companies may use USB to connect their sensor to a computer. Companies may also use surface battery packs (limited to 12 volts maximum) or the MATE supply to provide power for their water flow rate sensor. The independent sensor may only contain the intended sensor; thrusters, cameras or other systems **MAY NOT** be attached to the independent sensor.

Companies that use an independent sensor must provide a 3 amp (or less) fast blow fuse on the positive side of their connection. If companies are using the 12 volt MATE supply to power their sensor, both the ROV and the sensor must run through the single fuse before splitting off to the 3 amp sensor fuse. Companies using USB only to power an independent sensor may utilize the built-in current limiting of USB and do not need to add an additional fuse.

ELEC-002R: The ROV system must be capable of operating off the power provided by a MATE supply with a nominal voltage of 12 VDC. This voltage may be as high as 14.8 volts. Any power supplies used will be set at  $12.6 \pm 0.6$  Volts. At the international competition, power for the class will be provided by isolated power supplies. At regional competitions, power may be provided by isolated power supplies or batteries. Contact your [regional coordinator](#) if you have questions about the type of power source being used. Your system should be designed to work with the maximum specified voltage of 14.8VDC.

ELEC-003R: The ROV system may deliver any voltage to the ROV at or below the nominal supply voltage provided. Conversion of this voltage is allowed prior to it arriving at the ROV.

ELEC-004R: ROV systems may use any voltage desired up to 12 Volts.

ELEC-005R: Voltage may not be increased above the nominal 12 volts anywhere in the ROV system.

ELEC-006R: Sonar or other systems that may have DC/DC conversion resulting in voltages above 12V nominal are not permitted.

ELEC-007R: Voltages in excess of the class parameters set forth in this specification are not allowed on the ROV system at any time other than any inductive spikes that are caused by the switching on/off of motors, solenoids and other inductive devices. Companies should design their systems to handle these voltage spikes but will not be penalized for the presence of these in a system. For additional information on this, companies can research back electromotive forces (back EMF), collapsing magnetic motor fields, and transient suppression.

### ***3.3.1 Current***

#### ***NEW in 2016!!!***

ELEC-008R: The ROV system must have a fuse (or circuit breaker) that is calculated based upon the maximum current draw of the ROV. This overcurrent protection must be calculated as follows: ROV Overcurrent Protection = ROV Full Load Current \* 150%. The overcurrent protection value may be rounded up to the next standard fuse. In no case can that value exceed the 25A maximum. The fuse or circuit breaker must be installed in the positive power supply line within 30 cm of the power supply attachment point. The fuse may be a slow blow type. The SID and other electrical diagrams must show the fuse or circuit breaker and include the amperage of the overcurrent protection. In addition, the SID must show the calculations used in determining the overcurrent protection value. SIDs without these calculations shown will have 5 point deducted from Safety Points.

The MATE power supply will be protected by a 25 amp fuse; however, the ROV system must also have its own calculated fuse (or circuit breaker).

NOTE: Companies using circuit breakers for their overcurrent protection should ensure that the method used to house the circuit breaker is safe and not so large that it will cause undue strain on the power connector. In the past, oversized and heavy circuit breaker enclosures have caused companies to replace their circuit breaker box with a simple fuse. Anything deemed by the safety inspectors as being too heavy, a hazard, or not done in a workmanship manner will be rejected at the safety inspection.

ELEC-009R: ROV systems are allowed one replacement fuse during the product demonstration. In the event that the ROV system blows the second fuse during the demonstration, the demonstration will be over and no additional points will be earned. Companies should have adequate replacement fuses on hand, MATE will not provide replacements. Standard sizes for fuses and fixed trip circuit breakers are 15, 20, and 25 amps.

Additional standard fuse sizes are 1, 3, 6 and 10 amps.

### 3.3.2 Power Connections

#### **NEW in 2016!!!**

**ELEC-010E:** Power supply connections will be Red/Black Anderson Powerpole Connectors. Companies' ROV system power wires must have proper connectors to obtain power. The Anderson Power Connectors must be connected to the ROV power wires securely; use of a proper mechanical crimper is suggested. Hand crimp tools do not have the force necessary to ensure proper and safe connections. MATE will not provide companies with connectors or adapters at the 2016 International Competition.

<http://www.andersonpower.com/us/en/products/powerpole/pp15-to-45.aspx>

These are two-piece connectors as shown in the picture below.



#### **Part specification and part numbers**

Anderson Power Pole – Red and Black connector with 30 amp contacts

Red is connected to power supply positive.

Black is connected to power supply negative.

Since Anderson sells the connectors in 2500 and 200 piece quantities, these connectors are available from distributors.

#### Distributor Part Number:

Connector & Pins: Powerwerx WP30-10 (This is a kit with 10 connector sets and 30 amp pins for approx \$12 USD)

Recommended Crimper: TRICrimp

<http://www.powerwerx.com/crimping-tools/tricrimp-crimping-powerpole-contacts.html>

#### Connector Sources:

<http://www.powerwerx.com/anderson-powerpoles/powerpole-sets/30-amp-permanently-bonded-red-black-anderson-powerpole-sets.html>

<http://www.aesham.com/power-distribution/powerpoles/powerwerx-wp30-10/>

[http://www.gigaparts.com/Product-Lines/Power\\_2/Powerwerx-WP30-10.html](http://www.gigaparts.com/Product-Lines/Power_2/Powerwerx-WP30-10.html)

<http://www.hamradio.com/detail.cfm?pid=71-001833>

#### **Powerpole related links**

Powerpole Data Sheet

<http://www.andersonpower.com/global-assets/downloads/pdf/ds-pp1545.pdf>

Powerpole Description

[https://en.wikipedia.org/wiki/Anderson\\_Powerpole](https://en.wikipedia.org/wiki/Anderson_Powerpole)

Powerpole Assembly Instructions

<http://www.powerwerx.com/assembly.asp>

<http://www.wb3w.net/powerpoleinst.htm> (see the section on using the TriCrimp tool)

YouTube video for Assembly

Part 1: [https://www.youtube.com/watch?v=8\\_DPPuQN8R4](https://www.youtube.com/watch?v=8_DPPuQN8R4)

Part 2: <https://www.youtube.com/watch?v=EsSsr2zGFqI>

ELEC-011R: The power supply may be located up to 1 meter from the station table and may be located on either side of the table. MATE recommends a power cable long enough to reach the power supply up to 3 meters from your control system.

### ***3.3.3 Tether Voltages***

The signals in the tether must meet the following specifications:

ELEC-012R: Low voltage, low current AC or DC control or sensor signals. Low voltage is defined as a voltage equal to or less than the maximum supply voltage per class specification. Low current is defined as being less than 500mA.

**Note:** Companies concerned about how voltage loss will affect their camera(s) should consider adding a separate line in the tether to supply the camera from the main power source. This dedicated line for cameras is permitted, provided it runs through the single fuse or circuit breaker.

ELEC-013R: DC main-supply at a nominal voltage of 12VDC as provided by the MATE power supply.

ELEC-014R: Ethernet, USB, or other ANSI or IEC accepted serial protocol signals.

ELEC-015R: NTSC or PAL Video signals

ELEC-016R: Fiber optic cabling of any type may be used.

### ***3.3.4 Exposed connections and disposable motors***

ELEC-017R: ROVs with electrical connections that are exposed to water and not sealed are not permitted to enter the water. Taping a connection with electrical tape only does not constitute a sealed connection. The

process of sealing electrical connections must include methodologies such as, but not limited to, Silicone RTV, hot melt glue, epoxy, self-vulcanizing tape, and enclosure of the connections in a housing.

ELEC-018R: “Disposable motors” are not permitted; these are exposed motors with no waterproofing.

### 3.4 Onboard Electrical Power

ELEC-019R: Onboard electrical power (i.e., power not provided by the tether): Onboard battery powered devices are NOT allowed under any circumstance.

**NOTE:** *Water leaking into a closed battery container can result in the generation of hydrogen gas. This gas can build up inside a pressure housing and create an unsafe situation. For this reason, onboard batteries are NOT allowed under any circumstance. Any device that needs power must obtain that power directly from the ROV tether. For devices that operate at a voltage other than the tether voltage, an onboard ROV converter may be included. The converter must be sealed and not exposed to water. This rule includes commercial “watertight” battery containers; no battery of any type is permitted on any competition vehicle.*

### 3.5 Power Shutdown

ELEC-020R: For safety purposes, any ROV system that is disconnected from the surface supply must stop functioning in less than 5 seconds. This applies to electrical, pneumatic, and hydraulic power sources. Any filters, capacitors or accumulators must be sized accordingly to meet this specification.

### 3.6 Fluid Power

#### 3.6.1 Documentation

FLUID-001: Documentation required must include a fluid power diagram using industry standard symbols, showing all items, regulators, and control valves.

#### 3.6.2 Hydraulic Power

FLUID-002: Hydraulic fluid: Water or biodegradable food-grade fluid, only.

FLUID-003: If a biodegradable food-grade fluid is used, a Material Safety Data Sheet (MSDS) must be provided at the safety inspection. The MSDS must show the type of fluid used and its compatibility with the Biodegradable Food-Grade specification. Companies using water do not need to provide an MSDS.

FLUID-004: The following fluids are approved for use in hydraulic systems:

- a. Water
- b. Biodegradable Food-Grade Hydraulic Oil ISO Grade 32/46, SAE Grade 20, McMaster-Carr part# 3499K22

All other bio-degradable food-grade fluids must be approved by the [Competition Technical Manager \(mgardner@marinetech.org\)](mailto:mgardner@marinetech.org) by March 4, 2016.

FLUID-005: Maximum Hydraulic pressure allowed: 10.33 bars (150 psig).

FLUID-006: Hydraulic system: All lines, fittings, and hydraulic devices must be rated for a minimum pressure of two (2) times the maximum supply pressure.

FLUID-007: Hydraulic pumps must be part of the safety inspection.

1. They must have a pressure relief valve with a maximum setting of 300 psig or less installed before the pressure regulator.

2. The pump must have a regulator in place and set to 150 psig or less.

3. Pumps with any sign of external rust or deterioration will not be accepted.

5. All wiring must be secure.

6. All guards must be in place.

8. Hydraulic pumps may run off of the 15A 115VAC outlet provided for command and control as long as the hydraulic fluid is not used to propel the ROV. The hydraulic fluid is to be used for grippers and actuators only.

### ***3.6.3 Pneumatic Power***

FLUID-008: Pneumatic fluid: Compressed air or inert gas only

FLUID-009: Maximum pressure allowed: 2.75 bars (40 psig)

FLUID-010: Pneumatic system: All lines, fittings, and pneumatic devices must be rated for a minimum pressure of two and a half (2.5) times the maximum supply pressure. For example, if an 83 bar (1200 psig) tank is regulated to 2 bars (30 psig), then all system components must have a minimum rating of 5.17 bars (75 psig).

FLUID-011: Air compressors must be part of the safety inspection. .

1. They must have a pressure relief valve installed before the pressure regulator.

2. The compressor must have a regulator in place and set to 40 psig or less.

3. Compressors with any sign of external rust will not be accepted.

4. The tank drain valve must open.

5. If more than 5 ml of water exits upon opening the drain valve, the compressor will not be accepted.

6. All wiring must be secure.

7. All guards must be in place.

8. Air compressors may run off of the 15A 115VAC outlet provided for command and control as long as the air is not used for motor thrust. The air is to be used for buoyancy/ballast, grippers and actuators only.

### ***3.6.4 Pressurized Cylinders***

FLUID-012: Pressurized cylinders may be used, but must remain above the water surface and meet the following specifications:



- a. Approved by US DOT (Department of Transportation) or TC (Transport Canada). For regional competitions taking place outside of the US, check with your [regional coordinator](#) for approval.
- b. Have a current official inspection/test sticker and/or stamp.
- c. Stamped with the maximum allowable pressure.
- d. Contain a pressure relief safety device.
- e. May be filled up to the maximum allowable pressure of the cylinder.
- f. Must be regulated at its output to a maximum of 2.75 bar (40 psig).
- g. Must have an easily accessible shut-off valve that is clearly marked with instructions.
- h. May only be stationed on the surface, not on the ROV.
- i. Must be secured in a safe manner such that they will not fall or roll around. If the judges feel that a cylinder is unsafe, they have the discretion to prevent its use.
- j. SCUBA tanks are permitted. They must meet all the above specifications and have a current visual inspection sticker, or “fill permit” visible.

### **3.6.5 Pressure Storage Devices (Pressure Accumulators)**

FLUID-013: Pressure storage devices are allowed on the ROV if they do not exceed 1.25L in total storage and do not store pressure higher than the allowed pressure for air or hydraulics. It is recognized that a company may not be able to purchase a pressure accumulator that has the proper rating and fits in the space needed. In that case, the company must show that their designed accumulator is capable of withstanding the specified pressures without rupture.

### **3.6.6 Fluid Power Quiz**

FLUID-014: RANGER class companies planning to use hydraulics and/or pneumatics (i.e., fluid power) are required to take and pass an online quiz with a score of 100%.

*NOTE: The quiz was developed by MATE Center technical support staff and competition judges and is designed to ensure that companies understand basic information on these topics and can apply that knowledge to safe practices. The intention is not to add yet another “requirement,” but rather to provide a safe and successful learning experience and competition environment.*

*The quiz should be completed by the STUDENT company members. Each member of the company does NOT have to take the quiz; students can work together and make it a group effort. **ONLY ONE TEST PER COMPANY.** The company’s instructor or mentor can provide guidance and advice, but the questions should be answered by the students participating on the company. The quiz will be scored and the results provided instantaneously. **A score of 100% is considered a passing grade. Companies can take the quiz as many as 5 times to achieve this score.***

***The quiz must be completed with a passing grade by March 4<sup>th</sup>, 2016.** Companies failing to complete this quiz within the given time frame will NOT be permitted to use fluid power during their competition event.*

**New in 2016!!! FEE TO TAKE THE FLUID POWER QUIZ!** The fee to take the fluid power quiz is \$10 for five attempts (no discounts for fewer attempts) and must be paid for at the time of registration. Teams will see an option to purchase the fluid power quiz when they register. Within five business days of receipt of payment, teams will receive a link, username, and password to take the quiz.

*The following are sources of information on hydraulics and pneumatics. This is not intended to be an exhaustive list, but rather a starting point to encourage Companies to seek out additional information and resources.*

- **Underwater Robotics: Science, Design & Fabrication**, published by the MATE Center (see [www.marinetech.org/underwater\\_robotics](http://www.marinetech.org/underwater_robotics))
- <http://www.fxsupply.com/pneumatics/psafety.html>
- <http://mining.state.co.us/safety/downloads/ppoint/HydraulicPressureIntensification.ppt>
- National Fluid Power Association – <http://www.nfpa.com/education/mini-book.asp>
- Parker Hannifin Corporation – <http://www.parker.com/> (look for technical literature links)

### 3.7 Control Systems

ELEC-021R RANGER companies are not limited to the type of control system they may use provided it complies with the other MATE design and safety specifications.

#### **NEW in 2016!!!**

ELEC-022R: Surface control stations must be built in a neat and workmanship like manner. Loose components and unsecured wires will not pass safety inspection.

ELEC-023R: Surface control stations by nature combine 120VAC and 12VDC wiring. The surface control stations must be wired in a manner such that the 120VAC wiring is separated from the DC wiring and the 120VAC wiring must be clearly identified from the DC and control voltages. Identification can be through signage and/or wire color schemes. All 120VAC wiring colors must use ANSI, NEMA or IEC standard wiring colors appropriate to each voltage. There must be a sign inside the surface control station indicating which wiring standard is being utilized.

ELEC-024R: All wires entering and leaving the surface control station must have adequate strain relief and wire abrasion protection as the wires pass through the enclosure. Tape, zip ties, string and similar methods are not acceptable.

ELEC-025R: Any connectors utilized in the surface control station and elsewhere in the ROV system must be properly type rated for their application. AC rated connectors must not be used for DC. The connectors must also be rated at or above the voltage and current used in their application.

### 3.8 Command, Control, & Communications (C3)

### ***3.8.1 Power Provided***

CCC-001: Surface power: MATE will provide one GFI-protected outlet with a nominal 115 Volts AC (60 Hertz) and 15 amps maximum. This outlet is intended to provide power for pumps and other surface support equipment (e.g. video monitors & control boxes). This AC power source CANNOT be used to directly or indirectly power the vehicle.

CCC-002: If hydraulic or pneumatic power is used for vehicle thrust, the power for the pump must come from the MATE supplied DC power supply.

CCC-003: In addition to electric pumps, hydraulic, and pneumatic systems can be powered by manual pumps (e.g. bicycle tire pump) or supplied from a pre-pressurized cylinder. Companies that are only using manual pumps do not need to pass the fluid power exam.

### ***3.8.2 Displays***

CCC-004R: Companies are limited to a maximum of three video display screens. Companies may use an additional two displays for ROV status or sensor information.

CCC-005R: These display devices may be powered by the MATE provided GFI-protected 115-Volt AC (60-cycle) and 15-amp AC power source described in CCC-001, Surface power.

CCC-006R: A company's C3 station may include devices like video recorders. All C3 devices must be able to run on the single AC power outlet provided or on its own internal battery power. Any device plugged into this AC power outlet can only provide C3 functions and cannot provide power to the ROV.

## ***3.9 MATE Provided Equipment***

MATE will provide **NOT** provide video monitors at the product demonstration stations.

### ***3.9.1 Companies Sharing Equipment***

Companies may be allowed to share the following equipment during the competition event: monitors, joysticks, and compressors.

Companies may NOT share the following equipment during the competition event: control systems and payload tools (e.g. grippers, manipulators).

Contact your [regional coordinator](#) to determine if equipment can be shared at your regional event.

Companies that plan to share equipment during the international competition event must notify the [Competition Technical Manager \(mgardner@marinetech.org\)](mailto:mgardner@marinetech.org) at least 4 weeks prior to the event so that this can be considered when creating the schedule. MATE will do its best to accommodate companies sharing equipment.

### 3.10 Laser Safety Rules

LASR-001: Companies using a laser at the international event must inform the MATE Center and provide the **laser specifications by March 4<sup>th</sup>, 2016**. Information and laser specifications should be sent to the [Competition Technical Manager \(mgardner@marinetech.org\)](mailto:mgardner@marinetech.org). Specifications will be forwarded to the MATE Center safety inspection team for evaluation. Once the laser specifications are reviewed, a notification will be sent to the company. If the laser is being used at a regional event or pool practice, notification will also be sent to the regional competition coordinator.

LASR-002: All lasers must operate in the visible range at either the 630-680 nm (red) or near the 532 nm (green) wavelength. All lasers must fall into the Class I, Class II, or Class IIIa category. Red lasers must operate at 5mW or less. Green lasers must operate at 1mW or less.

LASR-003: Companies should include detailed specifications of their laser in their technical documentation as well as have that information ready and available during their safety inspection and product presentations.

LASR-004: Lasers must have an on/off switch. This switch must be on the surface controller.

LASR-005: All lasers must be powered by the MATE surface power supply. Batteries, including batteries for powering lasers, are not permitted on the vehicle.

LASR-006: Companies using lasers cannot increase the voltage or the current to increase the power of their lasers. Lasers must use the voltage and current set in their specifications.

LASR-007: When out of the water, the laser should have a shield or enclosed beam stop attachment within 30 cm of the laser. This means that the laser beam should not travel more than 30 cm before reaching the shield. This is a requirement at all times when the laser is out of the water. The shield does not need to be attached to the ROV while it is in the water. The shield must be painted with FLAT BLACK paint.

LASR-008: At no time should the laser be focused or deviate from a collimated beam.

LASR-009: When testing the laser at a workstation, companies must display a sign telling others that a laser is being operated.

LASR-010: Operators working with the laser while the ROV is out of the water should wear appropriate laser safety glasses at all times. This requirement is for all laser types. Search online to find laser safety glasses appropriate for the wavelength being used.

## PART 4: COMPETITION RULES

### GENERAL

- All members of the company and their supporters must follow the safety regulations of the ROV competition, pool facility, and event venue.
- All company members and their supporters are expected to conduct themselves in a professional and responsible manner during the competition. Disrespectful behavior towards the judges, officials, pool staff, audience, or other teams will lead to penalty points or disqualification.
- Sabotaging, stealing, or pilfering equipment of other companies will lead to disqualification. Companies found cheating will also be disqualified.
- The MATE ROV competition is, at its core, designed to be an educational and inspirational event for **STUDENTS**. It is designed to challenge them to apply the physics, math, electronics, and engineering skills they are learning in the classroom to solving practical problems from the marine workplace. (See the [MATE Competition Philosophy](#).)

It is expected that all “adults” (non-students; e.g. teachers, mentors, parents) involved in the competition limit their input to educational and inspirational roles. Actual construction of the ROV (particularly in the complex electrical and software areas) must be completed by the students. Adults should teach and advise students about design, electronics, software, and construction, but not complete the work for the students. Throughout the process adults are encouraged to focus on benefits to the students from the process and not simply winning. If it becomes apparent that adults exercised more than an advisory role, judges reserve the right to deduct points or, in extreme cases, disqualify companies from the competition.

While at any MATE ROV competition (international and regional), **ALL** work done on the vehicle must be conducted by company members. Teachers, mentors, parents, and non-competing students are not permitted to work on the ROVs. They may provide advisory input, but they may not work on the ROV directly. This includes writing or editing software code. All mechanical electrical and software modifications and/or repairs to the ROV must be completed by students.

- With learning at its core, the MATE competition encourages students to utilize and build upon their skill sets to find creative solutions to designing and building their ROV. As they move through the process of analyzing their designs and identifying building materials, students may decide to either build a component from “scratch” or purchase it from a commercial vendor. While original solutions are encouraged, the use of commercial components is acceptable, provided 1) that the components adhere to the design and building as well as safety specifications for the particular

competition class and 2) more importantly, that the students can provide a reasonable, logical explanation for buying versus building.

The competition scoring rubrics are designed to reflect this; points are awarded based on students' abilities to explain and justify how all of the components and systems work together as an integrated ROV, regardless if they purchased them, pulled them from public libraries, or made them themselves.

That said, it should be noted that purchasing and competing with commercial ROVs are not permitted.

## PROCEDURAL

- Companies must compete during their assigned time slots. Your company is **NOT** permitted to switch time slots with another team. Failure to show for your scheduled product demonstration or for your company's product presentation will result in "no score" for that particular competition category. **No exceptions.** Assigned time slots will be sent out in advance so that any scheduling concerns can be addressed prior to the event.

\*Regional contests may refer to the product demonstration station as the control "station" or "shack."

- While there is no limit to the number of students who can compete as part of a company, **the product demonstration team (aka demo team) is limited to six students.** The demo team is defined as the team of students who operate the vehicle and its associated equipment during the product demonstration. Only six students will be allowed to enter the product demonstration station, launch, pilot, and perform the tasks. Instructors, mentors, and/or non-student members cannot participate as part of the demo team. **Companies may alternate students on the demo team for the two product demonstration attempts.** (All members of the company should participate in the engineering and communication components; see [ENGINEERING & COMMUNICATION](#) for more information.)
- Only the demo team members and judges are allowed at the product demonstration station during the product demonstration, which includes the set-up and demobilization periods. Other members of the company, instructors, mentors, audience members, and observers (press or special invited guests) must remain outside the product demonstration station or in designated viewing areas.
- Instructors, mentors, parents, and "fans" are **NOT** permitted at the safety inspection stations or repair tables. Two warnings will be issued before individuals not heeding this rule will be asked to leave the venue.
- In addition, instructors, mentors, parents, and fans are **NOT** permitted to work on the ROV. Individuals who are seen working on the ROV who are not student team members will be issued a

warning. Two warnings will be issued before individuals not heeding this rule will be asked to leave the venue. If companies choose to take their ROVs off the competition grounds for maintenance and repair, they are expected to observe this rule in the interests of the spirit of the competition.

- To help enforce this, teachers, mentors, parents, and non-competing students MAY have limited access to the work station areas. Limited access can mean that these individuals are not permitted into the room or building where the workstations are located. Contact your [regional coordinator](#) or the [MATE Center \(jzande@marinetech.org\)](mailto:jzande@marinetech.org) for more information.
- Video devices may be used to record the underwater activities for entertainment and learning purposes **only**. Video will not be used as an instant replay to review judges' decisions or to challenge product demonstration timing.
- Product demonstration stations will be roped off and marked. Product demonstration stations will contain 2-3 chairs and one 6-foot table long table for teams to use. This table will be within 3 meters of the pool edge. Product demonstration stations will be set up to prevent the pilot(s) from looking at the ROV in or under the water except through the ROV cameras.
- Companies advancing to the international competition will need to transport their vehicle up and down a ramp to reach the pool deck.
- Companies will compete in one product demonstration that will consist of five tasks. Companies will get TWO attempts at the one product demonstration. The higher of the two scores will be added to the engineering and communication score to determine the total, overall score for the competition.
- The product demonstration time consists of a 5-minute set-up period, a 15-minute performance period, and a 5-minute demobilization period. If the demo team and all of their equipment are not out of the product demonstration station at the end of the 5-minute demobilization period, the team will be **penalized 1 point for each additional minute**.

**Note:** Regional competitions *may not* offer two attempts at the product demonstration. Regional competitions may allow more or less time to complete the product demonstration. Contact the [regional coordinator](#) in your area for more information.

- Manipulating the tether to free it from underwater obstacles is permitted. Pulling on the tether to speed up the recovery of items or to return your vehicle more quickly to the surface is not permitted and will result in penalty points. Judges will issue one warning if tether pulling occurs. Each future infraction will result in 5 points deducted from the final product demonstration score.

- SCUBA diver assistance will not be available at the international competition pool venue. If your vehicle is completely disabled and/or its tether tangled and unable to free itself in these venues, emergency divers can be called in to assist the vehicle only after all other vehicles are out of the water and/or shut down (i.e., no longer connected to electrical power). At that point, companies will not be able to continue the product demonstration. Companies will receive points for the tasks they have completed thus far, minus 5 penalty points for emergency diver assistance.

Diver assistance may not be available at your regional competition. Contact the [regional coordinator](#) to determine if diver assistance will be available at your regional competition.

- Pilots can only leave the product demonstration station and move poolside to repair, adjust, or alter a vehicle if the ROV is surfaced and at the side of the pool.
- Companies are not permitted to leave debris in the pool. Any debris must be recovered by the ROV before time has expired or the company will be penalized. Debris is defined as pieces of the ROVs, weights, floats, or other items created by the company. Task props are not considered debris. The product demonstration notes section may cover special items that can be left in the pool after time has expired.
- No demo team member shall enter the water to complete an object recovery. Only arms and hands are allowed into the pool to retrieve an object or to retrieve the vehicle. Companies will be disqualified or penalized depending on the severity of the infraction.
- Communication between demo team members at the pool edge and demo team members piloting the vehicle will be limited. Only tether management issues (e.g. how much tether is out, how much is remaining on the pool deck) can be discussed. Those team members at the pool edge cannot give any directional or product demonstration task information to the pilot. Judges will issue one warning regarding illegal communication. Each future infraction will result in **5** points deducted from the final product demonstration score.
- Communication using cell phones, text messaging, and online social media tools such as Skype, Facebook, Twitter, instant messaging, etc. is NOT permitted during the product demonstration, either between the demo team members at poolside or between any demo team member and anyone outside of the product demonstration station. The ROV and/or the ROV control system is not allowed to broadcast video or other information to anyone outside of the product demonstration area. No exceptions. Companies found broadcasting any data to those outside of the product demonstration area will be disqualified.
- **Product demonstration judges and other competition officials will only communicate with students.** Judges and officials will NOT communicate with mentors, parents, or other non-student members regarding product demonstration information, challenges, or other issues except during pre- and post-competition briefing sessions.



## DESIGN & SAFETY CONSIDERATIONS

- The competition coordinators and host venues stress the importance of safety practices and procedures to all companies. The score sheets will reflect the MATE Center's efforts to encourage and reward teams that demonstrate exceptional safety practices and procedures.
- **ALL ROVS MUST PASS A SAFETY INSPECTION CONDUCTED BY COMPETITION OFFICIALS PRIOR TO ENTERING THE POOL.** These inspections will be conducted topside to ensure that ROV systems meet the design and building specifications and do not pose a risk to the integrity of the event venue. See [VEHICLE DESIGN & BUILDING SPECIFICATIONS](#) for additional information.
- Radio transmitters that operate on a separate battery are permitted. No batteries are permitted to be in or on the water. No exceptions.

Teams should be aware of all the implications of these wireless devices. There is no assurance that an adjacent company's wireless controller will not interfere with your control systems. Adjacent wireless controllers with a battery that has a higher charge than the nearby controller have demonstrated the ability to "hijack" the nearby control signals. In addition, all wireless controllers are susceptible to external sources of electronic interference. Your system may work fine in your home environment, but not in the industrial environment of the competition. MATE will not stop the clock to resolve wireless control issues. Companies deciding to utilize wireless controllers do so at their own risk.

- Keep an eye out for tripping hazards in the product demonstration station and at your company's work station. Make sure power cords are not laying in pools of water on the deck.
- During your product demonstration, be sure to secure any equipment so that it does not fall off the product demonstration station table, damage the deck, or cause injury.
- Loose fitting clothing, jewelry, and long hair could all become safety issues. Consider securing long shirts or baggy pants, removing jewelry, and tying back long hair when working on or operating your ROV.
- ROVs may be constructed out of materials of your company's choice, provided they meet the design and building specifications and safety regulations. Warning labels should be posted on potentially hazardous components of your ROV system.
- All company members must wear close-toed shoes and safety glasses or goggles. **IMPORTANT NOTE FOR 2016!!!** The international host venue will have personnel at the door of the work station area checking EVERYONE who enters. **No one will be allowed into the work station area without**

**close-toed shoes and safety glasses or goggles. No one will be allowed on the pool decks without close-toed shoes.** This includes company members, parents, mentors, and guests. Safety glasses/goggles are also recommended when working with your vehicle on deck.

- Personal flotation devices (PFDs) will not be required at the international competition; lifeguards will be on duty. No personal flotation devices will be provided by MATE or the host venue. Regional events may require PFDs. Contact your [regional coordinator](#) to determine if PFDs will be necessary.

## **PART 5: ENGINEERING & COMMUNICATION**

The ability to effectively communicate information about your vehicle and the design and building process is equally as important as how well your vehicle performs. Strong communication skills are an essential part of good business practices. To emphasize this point, the competition requires the following four engineering and communication components:

- Company Spec Sheet
- Technical Documentation (formerly known as the technical report)
- Product Presentation (formerly known as the engineering presentation)
- Marketing Display (formerly known as the poster display)

**NOTE: Regional contests may not require all of the Engineering & Communication components. Contact your [regional coordinator](#) for more information.**

The Company Spec Sheet, Technical Documentation, and Product Presentation are components where you are communicating with technical audiences, such as potential future clients. (Examples of spec sheets and technical documentation from previous competitions can be found [www.marinetech.org/tech-reports](http://www.marinetech.org/tech-reports). Examples of product presentations can be found on [MATE's Vimeo channel](#).) The Marketing Display should be thought of as part of your marketing (or sales) strategy and aimed at general (including non-technical) audiences.

### **TIPS FOR EFFECTIVE WRITTEN AND ORAL COMMUNICATION**

Communicating ideas about how to solve a problem and evaluating those ideas against competing alternatives is a critical skill for anyone thinking about a career in marine technology. It is a skill that is directly linked to decision making about whether or not to hire (or fund) us and our ability to influence the work that we do.

The key to a successful technical documentation and product presentation is the way that critical thinking and engineering reasoning are communicated. You can think of the process as technical “storytelling.”

Technical storytelling includes the use of text, images, schematics, and data to effectively communicate the “story” of how your company brainstormed and evaluated ideas to come up with your solution (e.g. ROV, payload tools, and operational strategies) to the problem at hand (product demonstration tasks). It also involves organizing content to efficiently present your work and justify why you did what you did.

However, choose details with care. Each detail should help to answer the question "why is what you did the best solution for your team and for this competition?" Describe why a component in the system is critical and how you chose it. Include specifications or dimensions only if they help to explain the “why” and “how” you made choices. Keep in mind that a mechanical drawing with dimensions can replace a lot of text and in many cases do a better job telling details of the story than text.

Maintaining a project notebook is a good business practice that will help to capture ideas and document your company’s progress – including your research, designs, trade studies, experiments, data, vehicle specifications, testing, expenditures, and donations. The notebook is also a place to keep track of your company member’s contributions (time, support, etc.).

Along with your notebook, here are some items to consider as you prepare to tell your story:

- What was your team's "work breakdown structure" (tasks, time, and people)?
- What were the greatest constraints (schedule, budget, equipment, labor, logistics, etc.) on your design process?
- How did the product demonstration tasks and rules influence your design and decisions?
- What systematic process, such as a [tradeoff matrix](#), did you use to evaluate competing design solutions?
- What were the most important design decisions you made and why?
- How did you arrive at your final power budget? What concessions, if any, did you have to make and why?
- How do you calibrate your sensors?
- If your vehicle uses software, where does the code execute? Describe the flow and format of the data.
- Did you have a noteworthy troubleshooting experience? Any problem or procedure that takes more than 20 minutes to figure out is worth understanding and writing down.

Your company should also review the scoring rubrics posted on the MATE web site under [Missions, Specs, and Scoring](#). The rubrics are what the judges will use to evaluate and score your technical documentation, product presentation, and marketing display.

## COMPANY SPEC SHEET (ONE PAGE ONLY)

Your company is required to submit a one-page spec sheet along with the Technical Documentation (see below). The goal of the spec sheet is to provide the judges with a “snapshot” of your company. It includes basic information about your company and vehicle.

**Companies must submit their spec sheets to their [regional coordinator](#) 2 weeks prior to their regional event. Companies demonstrating their vehicles via video must submit their spec sheets to the [MATE Center](#) 2 weeks prior to their demonstration. Companies advancing the international competition must submit their spec sheets to the [MATE Center](#) on May 26<sup>th</sup>, along with their technical documentation.**

Company spec sheets will be reviewed by safety inspectors as well as judges.

Companies will receive 10 points for submitting a spec sheet that contains all of the following information:

### COMPANY SPECS

- **Company and school, club, or community organization name**
- **Home state and/or country**
- **Distance required to travel to the international competition**
- **History of MATE ROV competition participation.** Be sure to specify if your company and/or the members of your company are “new” or “returning.”
- **Company photo and caption indicating members’ names and roles (e.g. CEO, CFO, Design Engineer, Pilot, etc.).** This photo should include all of the members of your company.
- **Range of grade/college levels represented by the members of your company**

### ROV SPECS

- **ROV name** if applicable
- **Total cost.** You must include the approximate cost of any donated items.
- **Total student-hours to design and build.** This should include the number of hours that each and every member of the company worked on the vehicle.
- **Safety features**
- **Special features**
- **Photo of the vehicle**

## TECHNICAL DOCUMENTATION

Your company is required to submit technical documentation that will be reviewed and evaluated by a panel of working professionals – individuals who represent science, exploration, government, and industry. (These individuals may not be the same judges who evaluate your company’s product presentation.) The technical documentation is a means for your company to describe the design, operations, and features of your vehicle. Your clients should gain a good technical understanding of your vehicle and your company’s capabilities in addressing your client’s needs for an ROV.

If your regional competition requires technical documentation, contact your [regional coordinator](#) to determine the date the technical documentation is due. For RANGER companies advancing to the international competition, technical documentation must be submitted to the [MATE Center](#) by May 26<sup>th</sup>, 2016, which is 4 weeks prior to the competition date. The technical documentation should be in searchable PDF format (see <https://fd4686477cb19f983f54-68abf00cbc1a2cc111562c013cb867db.ssl.cf1.rackcdn.com/SearchablePDFs.pdf>) and not exceed a file size of 8MB.

Technical documentation and company spec sheets must be submitted via:

- Dropbox. Teams can upload their files to a Dropbox folder and share that folder with the [MATE Center](#) ([jzande@marinetech.org](mailto:jzande@marinetech.org)); OR
- Google Drive. Teams can upload their files to Google Drive and share the file with the [MATE Center](#) ([jzande@marinetech.org](mailto:jzande@marinetech.org)).

NOTE: By submitting your technical documentation and company spec sheet, you are giving the MATE Center permission to publish these documents on its web site.

Any changes or additions that you make to your ROV that differ from the information in the technical documentation that you submit should be presented to the judges during your company's product presentation. **NOTE: The judges will not review and rescore revised versions of your technical documentation during the competition.**

Each judge on the panel will award a score (100 points max). Judges' scores and comments will be returned to you shortly after the event.

The guidelines and required components for the documentation are:

**NOTE: Make sure to label any and all figures, graphs, diagrams, and photographs. Also note that these components must be present in your report, but you must determine the best logical order for presenting you them.**

- **Length is 25 pages or less – NO EXCEPTIONS**
- **Font size of at least 12 points (font type can vary)**
- **All measurements are in SI units (metric)**  
Exceptions include ½-inch PVC pipe and other items described or sold in imperial units.
- **Title page** must include:
  - Your company's name
  - School, club, or community organization's name, city, and state. If you are an international company, include the city and country.

- **COMPLETE** list of the members of your company and their role (CEO, CFO, Design Engineer, Pilot, etc.). You can also include degree/area of study (or what you plan to major in at college) and expected graduation date.
- Names of your instructor(s) and/or mentor(s).
- **Abstract (250 words or less)** that is concise and clearly summarizes the project.
- **Table of contents**
- **Photograph(s) of your completed ROV**  
Include photo(s) of your completed vehicle and other photos or sketches that capture the vehicle's design features. Captions should accompany all photos.

You are permitted to make modifications that may change the look of your vehicle between the time you submit your report and the competition; however, in your technical documentation you must include a photo(s) of your completed, intact vehicle, not photos of individual systems and/or payload.

- **Project costing**  
Project costing is an accounting of your income, donations, and expenditures. Items **must** be listed as one of the following: purchased, re-used, parts donated, or cash donated. For re-used or donated items, report the item's **current market value** and note the source or organization that made the donation. See the project costing sheet located [here](#) for an example.
- **Budget**  
At the beginning of the project, companies should establish a budget. A budget is different than a project costing sheet in that it is a projection of the cost of the project. Companies should create categories and realistically estimate what they think that they will spend in each. If well-thought through, the project costing will align with the budget (i.e., the amount budgeted for a certain category will be the actual amount spent!). **The budget can be included as an appendix.**
- **System Interconnection Diagram (SID)**  
A SID is a system-level, connection diagram that includes electrical and, if applicable, fluid power wiring information. Board-level and component-level schematics should not be included; however, these may be brought to the product presentation for reference purposes. The intent is to provide the competition judges with a one-line diagram showing how the various systems are interconnected without the detail of each and every wire.

The SID must include a clear distinction between the surface controls and the ROV. SIDs must be computer-drawn; hand-drawn or scanned diagrams are not acceptable. Any electrical, hydraulic, or pneumatic symbols must be ANSI, NEMA, or IEC recognized symbols. [VEHICLE DESIGN & BUILDING SPECIFICATIONS](#) includes additional details about the SID.

Note: Companies may use free drawing software such as [OpenOffice](#) to complete the SIDs.

- **Block-diagram or flow-chart of software in the ROV (if applicable)**  
This flow diagram should detail the software code written for your control system or other elements of your ROV. If you are using a purchased control system that utilizes software, you are encouraged to learn about its operation and describe it in a diagram.

- **Design rationale** presented in a clear and logical manner. This section should comprise the bulk of your report. *It should focus on the technical aspects of your vehicle and how your ROV was built to perform the specific tasks.* It should include information about the new vs. used as well as the original vs. commercial components you used and why you made the design choices that you did. See the questions under [Product Presentation](#) below for an example of information that you should cover.
- **Safety.** This section should describe the steps that your company has taken to identify and address any safety concerns regarding the design, construction, maintenance, and operation of your vehicle.
- **Description of challenges** that your company faced and how you overcame them. This should include both a technical challenge and a challenge related to working as a team. Be sure to explain how you overcame these challenges.
- **Description of lessons learned and skills gained** during the design and building process.
- **Discussion of future improvements**  
In this case, the MATE Center is your “client” and has defined both the problem to be resolved and the products and services you need to provide. However, future clients could include research institutions, private companies, and government agencies. A synopsis of ideas for future improvements is essential to any entrepreneurial organization.
- **Reflections on the experience**  
This can be written from the point of view of your company as a whole or individual members of the company can contribute a reflection. It can include personal or professional accomplishments achieved as a result of participating in the competition.
- **References**  
List any books, journal articles, magazines, trade publications, web sites, and professional advice that you used as sources of information for your work.
- **Acknowledgements**
- Please recognize your sponsors (companies, organizations (including the MATE Center), professionals from industry, and/or mentors) and the type of support that they provided (funds, building supplies, equipment, site visits to facilities, time, and/or technical expertise). You can include organizations and/or individuals that provided logistical and/or moral support (e.g. your parents, siblings, or pets). Regional competition teams should also acknowledge regional contest supporters.

## PRODUCT PRESENTATION

During the competition, your company is required to give a 15-minute oral presentation to a panel of working professionals – individuals who represent science, exploration, government, and industry. (These individuals may not be the same judges who evaluate your company’s technical documentation.) Your presentation should describe the engineering behind your vehicle’s design and operation and address any possible safety issues. It should also highlight any design innovations or creative solutions to solving the product demonstration tasks. After the presentation, the judges will take 10-15 minutes

to ask the members of your company questions about your ROV. The judges will evaluate both your presentation and responses to their questions.

**All student members of your company must participate in this presentation and question and answer (Q&A) period.** You are required to have your ROV with you.

**NOTE:** The product presentation is designed to be a face-to-face interaction where students and representatives from industry become engaged in conversation. MATE will not provide audio visual aids, such as slide projectors, computer projection screens, white boards, etc.; however, you are welcome to distribute handouts to help judges better understand the information that you are presenting. **PowerPoint presentations are NOT permitted.** During the Q&A, all members of the company must be present and prepared to answer.

**Instructors, mentors, family members, friends, and members of other companies are permitted to attend.** However, we ask that those in attendance be respectful and courteous throughout the presentation and follow-up question and answer period. Be mindful that this presentation may be a stressful time for the students. If the room becomes crowded or the spectators become distracting, it is up to the judges' discretion to request that some or all spectators leave the presentation. **While they are permitted to attend, instructors and mentors are not allowed to participate.**

Each judge on the panel will award a score (100 points max). Judges' scores and comments will be returned to you shortly after the event.

The judges will pay particular attention to whether or not the vehicle was built by the students from "scratch" or excessively uses complete, off-the-shelf systems. The use of complete, commercially-available systems is highly discouraged (the [COMPETITION RULES](#) includes more information on this topic). Design originality and innovation as well as safeguards to prevent injury or damage to the underwater environment will be noted.

Here are some examples of questions that the judges may ask or observations they may make. **NOTE: These are only examples and may not be the actual questions asked.** Your company must be prepared to answer questions other than those examples listed below.

### **Structure**

- How did you decide on the shape of the vehicle and the materials used to build it?
- What is the design depth rating of your ROV? Did you test this? How?
- Did you use any pressure housings in your design? Explain how you designed and built these.
- What are o-rings and how do they work?
- How much did it cost to build your vehicle?
- How much does your ROV weigh in air? In water?

### **Control system**



- What type of control scheme have you used? Why?
- How does your control system work?
- How many conductors are in the tether?
- What devices/functions does your system control?
- Is there some unique feature of your control system?
- How did you waterproof your underwater electrical connections?

### **Propulsion**

- How many thrusters does your vehicle have? Why?
- How much thrust does each produce?
- How many watts does one thruster use at full rpm?
- How many amps does one thruster draw under full load?
- How much electrical power does the vehicle draw when all the thrusters are in use? Have you measured this?
- Explain how you measured thrust.
- How is power (watts) used by one thruster related to the thrust it produces?
- Do you know the forward speed of your ROV? How did you measure this?

### **Ballast System**

- How does your ROV ballast system work?
- Explain what stability is.
- Why is it important to consider stability in the design of ROVs?

### **Sensors**

- What type of camera(s) did you choose? How did you waterproof it?
- What do your sensors measure or detect?
- What unique features are incorporated into your sensors?
- What additional sensors (other than a camera) have you put on your ROV? Why?

### **Payload Tools**

- What type of payload tool(s) did you design to accomplish the product demonstration tasks and why?
- Explain how the tool(s) works.

### **Resources**

- Did the project stay within budget? If not, why?
- What equipment/building supplies were donated, built, or bought? What strategies did you use in your fundraising?
- Were you able to produce a functional vehicle that can accomplish the tasks? What tasks did (or do) you still have difficulty completing?

### **System Design**

- What are the strengths of the design? How will they affect the vehicle's performance?
- What are the weaknesses? How will they affect the vehicle's performance?
- Do the safety systems work? How did you come up with them?
- An ROV consists of many systems that are made up of many components. How did you decide which components to build and which components to buy?
- Did you reuse any components that you had built for a previous competition ROV? How did you decide which components to reuse and why?

### **Originality**

- Does the design of the vehicle and its systems exhibit unique concepts and innovation? What are they?
- Does the vehicle make excess use of commercially-available systems? Why or why not?
- Are there any innovations or modifications that resulted in higher functionality and reduced costs?
- If you are using the same vehicle as last year, why? What are the advantages? What, if any, modifications or additions did you make?

### **Workmanship**

- What is the overall quality of the workmanship?
- Are the electrical systems neatly contained and wired?
- Is it easy to access components for maintenance? If not, why?
- Is the tether neatly bundled and protected? How did you accomplish this?
- Can the tether withstand the strain from the vehicle weight, handling, and operation? How?
- Does the vehicle look aesthetically pleasing yet have practical functionality? Why do you think so?

### **Safety**

- What potential safety hazards did you identify then address?
- Are warning labels and safeguards posted on potentially hazardous components?
- Did your team develop a safety checklist or protocol?

### **Theme**

- In the real world, what role do ROVs play in the competition theme?
- What types of organizations' or individuals' work relates to the competition theme?

### **Preparing for your product presentation and Q&A**

- Make sure that every member of your company has a good, general working knowledge of your vehicle, even though they may have specialized in one specific aspect of its design and construction.
- Research the specifications of the components that you use in your vehicle. For example, look up the specs of your ROV's camera and be familiar with such numbers as the amount of propulsive force the thrusters produce, the weight of your ROV, etc.

- Make sure that all the members of your company are familiar with your technical documentation. Ask every member to read it over to catch any errors or omissions. This exercise will help to familiarize everyone with all aspects of the project.
- Generally, you will have more to say about your ROV than can be presented in 15 minutes. That is why it is critical to organize your material and practice communicating it. However, avoid coming across as having memorized your presentation verbatim. Judges want to see that you are prepared and understand the information, not that you can simply regurgitate a rehearsed speech from memory. Ask your instructors or mentors to give you feedback.

**Other important items**

- If during the product presentation it becomes apparent that instructors, mentors, and other adults associated with your company exercised more than an advisory role, judges reserve the right to deduct points or, in extreme cases, disqualify teams.
- Your company is discouraged from using off-the-shelf, plug-and-play systems. You are encouraged to demonstrate innovation and creativity in the construction of your vehicle and its systems. This will also be reflected in your score.

**MARKETING DISPLAY**

Your company is required to create a display that will be showcased during the competition event. Your display should be an informative, clear, and concise presentation about your company and how you designed and built the specialized tools to effectively complete the product demonstrations. During the competition, your company’s display will be evaluated and scored by a completely different group of working professionals – individuals who will represent science, business, government, industry, and education/outreach.

While some judges will have a technical background, others will have a communications, marketing, or public relations background. In addition, there will be visitors to the competition who may not completely understand what an ROV is or how it is used. Think of these visitors as potential future clients who may authorize funding for your work, but have a limited understanding of the technology (i.e., you need to explain your technology, the tasks at hand, and “sell” them on YOUR products and services). Design your display to communicate to this type of audience.

Each judge will award a score (50 points max). Judges’ scores and comments will be returned to you shortly after the event.

\*\*\*\*\*

**INTERNATIONAL COMPETITION ONLY!**

**The MATE Center will supply one, 3-panel tri-fold display board to companies upon request.** If your company will need a presentation board provided by the MATE Center, please contact the [Competition Coordinator](#) by May 26, 2016 with the request.

Each display board is:

- Made out of black, corrugated cardboard
- 36" tall with a total width of 48"
- Comprised of three panels
  - One 24" wide by 36" tall center panel
  - Two 12" wide by 36" tall side panels

**Note: If you are providing your own display board, the space that the text and photographs/graphics occupy CANNOT exceed 36" tall by 48" wide. For example, company names CANNOT be mounted above the display board. NO EXCEPTIONS!**

At the international competition, tables will be provided for the displays. Contact your [regional coordinator](#) to see if tables ( easels or other) will be provided at your regional event.

MATE will provide scissors, tape, glue sticks, adhesives, and other means of attaching display items to the presentation board, although you are also welcome to bring your own.

\*\*\*\*\*

The guidelines and required components for the marketing display are:

**Note: Keep in mind that, at the international competition, with up to 60 marketing displays to score, the judges will have approximately 10 minutes to evaluate your display. Make key points. Be concise. Keep the general public in mind. Also, make sure to label any and all figures, graphs, diagrams, and photographs.**

#### GENERAL GUIDELINES

- **Font size that is clearly legible from a distance of 1.5 m**
- **Choose a font style and use it throughout**
- **All measurements are in SI units (metric).** Exceptions include ½-inch PVC pipe and other items described or sold in imperial units.
- **Include headers (see REQUIRED COMPONENTS below)**
- **Photos should be clear and high-quality for the print sizes that you choose**
- **EVERY PHOTO MUST HAVE A CAPTION!** No caption = no credit for that photo. Also include photo credits if the photo was not taken by someone in your company.
- **Items that you MAY include on your marketing display:**
  - Diagrams or sketches (CAD drawings, for example). The diagrams should be clearly labeled with a brief explanation that is understandable to a general, non-technical audience. For example, technical – a photo caption reading "ROV control system (Radio Shack project box part #123) with 3 DP/DT momentary switches (part #444)" vs. non-technical – "a photo of the ROV highlighting its control system." If they are overly complicated and require more technical knowledge, do not include them; technical drawings belong in your company's technical documentation.

- **Items that you MAY have on display include:**
  - Photo journals, pamphlets
  - Copies of your company’s technical documentation
  - Resumes and business cards of the members of your company
  - Company Spec Sheet and safety manual
  - Descriptions of mentoring or community outreach that your company participated in
  - MEDIA OUTREACH (international competition ONLY)
- **Items that you MAY NOT include in your marketing display:**
  - Flip charts on the poster board
  - Video screens on or in the actual poster board

## REQUIRED COMPONENTS

**Note: The following are REQUIRED headers.** These headers not only assist the judges in evaluating your display, they also make your marketing display easy to read.

- **Company name and school, club, or community organization name (note that this is the only personalized header)**  
 Make sure that your company name is in large, bold font (larger than any other font on your marketing display). Include your school, club, or community organization name as well as your company name. Include your geographic location (i.e. city, state, and country).
- **Abstract (concise – 250 word limit)**  
 Include an introduction to your company and how your company designed and built specialized tools to effectively complete the product demonstration tasks. Make sure to relate the product demonstration to how ROVs can be used in the real world. Don’t assume that your audience knows what an ROV is or the details about the competition tasks. You can view this section as a summary of your company information, design rationale, and theme.
- **Company information**  
 Include photo(s) (group or individual) of all of the members of your company. Provide a brief description of each member. This description should include the person’s name, role in the company (e.g. CEO, CFO, design engineer, pilot, marketing and communications specialist, etc.) and their qualifications, such as grade level, major or area of expertise, career goals, etc.
- **Design rationale**  
 This section should be the bulk of your marketing display. It will be worth the most points.
  - Why did your company build your ROV the way that you did?
  - Present your ROV’s “Features and Benefits.” Features are the physical aspects or specifications for your vehicle, and benefits are what those features provide for the customer. For example, a feature might be a one horsepower thruster; the benefit would be the ability to make headway in a 2 knot current.
  - Highlight your vehicle’s safety features.
  - Include photos of your ROV. Make sure to highlight the various systems of your vehicle.
  - **Include photos or drawings of any special features of your vehicle and how these features relate to the product demonstration tasks, safety, general operations, etc.** This is the most important part of your design rationale.

Last year's winning marketing displays are examples of how you can effectively present this information to a non-technical audience. The 2015 top EXPLORER and RANGER marketing displays are published [here](#) in the Journal of Ocean Technology.

▪ **Theme**

Describe this year's competition theme and how technologies developed for space can be used in the ocean – and vice versa.

Rather than regurgitating information that you find within the competition manual or on the Internet, take the time to think through the competition challenges and their significance in the real world. You can choose to focus on the technical, economic, or socioeconomic issue. In addition to the Internet, you are encouraged to contact individuals (such as a local scientist or industry professional) who can offer their views. You should include appropriate photos, diagrams, or sketches with captions. Be sure to appropriately cite your references / sources at the bottom of this section.

▪ **Company Evaluation/Market Assessment**

Answer the following questions thoroughly and thoughtfully:

- How would you characterize your company's overall success?
- What do you consider strengths of your company and the ROV you designed?
- What areas do you see needing improvement?
- What was the most rewarding part of this experience?
- What would you do differently next time?

▪ **Acknowledgements**

Please recognize your sponsors (companies, organizations (including the MATE Center), professionals from industry, and/or mentors) and the type of support that they provided (funds, building supplies, equipment, site visits to facilities, time, and/or technical expertise). You can include organizations and/or individuals that provided logistical and/or moral support (e.g. your parents, siblings, or pets). Regional competition teams should also acknowledge regional contest supporters.

**Note:** "Accessories" such as video footage, PowerPoint slide presentations running on laptop computers, video projections, etc. are permitted but should be used with discretion. Remember that the judges will have a limited amount of time to evaluate your marketing display and may find excessive use of audio or video presentations distracting.

However, if you do make a video of your ROV building or competition experience, please submit information about it to the [MATE Center](#) so that it can be shared via MATE's YouTube and Vimeo channels.

## **BONUS POINTS FOR MEDIA OUTREACH – INTERNATIONAL COMPETITION**

Companies that participate in the international competition can earn bonus points by writing a press release and working with their local media to publicize their company's participation in the competition. This can help you gain community support, media exposure, and local sponsorship.

***NOTE: MATE is no longer collecting paper copies of media articles from the marketing display area. You must [submit your results electronically](#) by the first day of the competition (June 23). Include the URLs for all media articles you have obtained. If the article was not posted online, please scan a hard copy and include it with your electronic submission.***

**The media outreach component is worth 5 bonus points in addition to the 50 total points awarded for the marketing display.**

Media outreach consists of:

- Developing a list local media contacts
- Writing a press release about your participation in the MATE ROV competition
- Distributing it to your media contacts
- Following up with your media contacts to see if they're interested in your company and its ROV
- Compiling a summary of results
- [Submitting your results electronically](#)

Please submit a copy of your press release, a copy of your media contacts list, and a summary of news articles, TV or radio coverage, etc. that your team received. Include copies of articles and URLs, and list any television or radio coverage. Be sure to include name of outlet, date, and a summary of the coverage.

### **Media Relations Guidelines**

Here are some general guidelines for working with the media.

1. You should begin your media effort about 4-5 weeks before the international competition (which is from June 23 – 25, 2016).
2. Write a press release highlighting your company's involvement in the upcoming MATE competition. If you participated in a regional, feel free to talk about it and how you performed. It doesn't have to be more than 1-1 ½ pages, double-spaced. Be creative.
3. Develop a list of community news media contacts, including newspapers, magazines, radio stations with public service announcements and local news, television news programs, and local online news reports or blogs. If your town is small and doesn't have any media outlets, reach out to those in the city or large town that's closest to you.
4. Try to find the name and email address of a reporter who covers education or technology—they're the ones that will be most interested in your story. You can often find this information online, or

you may have to call the media outlet and speak with a receptionist to find out who the most appropriate contact is and how to reach them. Usually, email is the best way to contact a reporter.

5. Become familiar with the news outlets and the reporter that you're going to "pitch" your story to. For example, learn if they've written about your school before, or what kinds of news stories they tend to develop.
6. Compose an email introducing yourself, your company, and your school. Tell them that you're participating in the Marine Advanced Technology Education (MATE) Center's international ROV competition, which will be held in June 2016 at the NASA Johnson Space Center's Neutral Buoyancy Lab in Houston, Texas. Explain what ROV stands for, and tell them how ROVs are used in the real world. Give examples of the skills that you and your teammates have learned by designing, building, and piloting ROVs. You may have already written some of this information for your marketing display or technical documentation.
7. Reporters are interested when a local team is participating in an international event. So make sure to let them know that the MATE competition is an international competition, funded by the National Science Foundation, the Marine Technology Society ROV Committee, and other international organizations and businesses, and that teams from all over the world participate. Be sure to provide the link to the [ROV competition web site](#).
8. Copy and paste the press release below your email. (Reporters in general prefer cut and pasted releases to opening up an attachment.) If you have any photos of your team and/or ROV, especially a photo of your vehicle in action, feel free to attach the photo to the email. Explain to the reporter what's going on in each photo you attach.
9. Make sure you include your name and a phone number where the reporter can reach you. Also include MATE's contact information and let them know they can contact MATE (via Jill Zande at [jzande@marinetech.org](mailto:jzande@marinetech.org)) if they want more specific information about. .
10. After you've emailed your media contacts, wait for a week and email them a reminder if you don't hear back from them.
11. If a reporter calls and wants more information, be creative about how you provide it. Offer to give interviews with a few of the company members, your mentor, or even a key sponsor. Invite them to meet you at the pool to see your ROV in action. Ask them if they want to try piloting the ROV on their own. If they want to speak with someone from MATE, give them the MATE media contact information from above.
12. If your team receives media coverage, capture the URL of the article, video or audio. If not, scan in any printed articles, or for audio/video, list the name of the media outlet, name of reporter, date and time of broadcast and summary of the broadcast. Include these in your electronic submission. Remember, we are no longer collecting paper forms or article copies.
13. To earn the five extra points, you must [submit your results electronically](#) by the first day of the competition (June 23, 2016), including:
  - a copy of your press release
  - a sample of your "pitch" email
  - your list of media contacts



- copies or lists/summaries of media coverage

Below is the sample press release to help you get started.

**Bridgewater High School Students to Participate in International Underwater Robotics Competition**

~~~~~

**Local students develop underwater robots and learn how they are used to explore the oceans and outer space at MATE International ROV Competition to be held at NASA**

April 15—Bridgewater, Mass.—A team from the Bridgewater High School (BHS) has been selected to compete the Marine Advanced Technology Education (MATE) Center’s 15<sup>th</sup> Annual International Student ROV Competition. Remotely operated vehicles, or ROVs, are tethered underwater robots used to complete tasks in underwater environments. The BHS team will compete against more than fifty teams from around the world, using an ROV that they designed and built during the past school year.

At the International ROV Competition, which will be held June 23 – 25 in Houston, Texas, BHS will compete against the top teams from MATE’s network of regional competitions. BHS was one of the winners in the MATE New England Regional ROV Contest, which was held last week.

Each year, MATE’s ROV competition encourages students to learn and apply science, technology, engineering, and math skills to complete tasks that simulate real-world problems from the ocean workplace. To learn entrepreneurial skills, student teams must form “companies” that produce ROV products to complete a specific set of tasks.

This year, the contest focuses on how technologies developed for use in the ocean can also be used in outer space – and vice versa. The NASA Johnson Space Center’s Neutral Buoyancy Lab will host the competition events.

At 200 feet long, 100 feet wide, 40 feet deep, and holding 6.2 million gallons of water, NASA’s Neutral Buoyancy Lab (NBL) is the largest swimming pool in the world. It simulates the zero-g or weightless condition that is experienced by spacecraft and crew during space flight. The NBL is an essential tool for the design, testing, and development of the International Space Station and future NASA programs. Astronauts use the facility to train for extravehicular activities, known as EVAs or “spacewalks.”

Teams will participate in ROV product demonstrations that require them to pilot their vehicle to complete tasks such as exploring the ocean that exists below the sheet of ice that covers Jupiter’s moon Europa; recover mission-critical NASA equipment from the Gulf of Mexico; collect and analyze oil samples from the Gulf to determine their origin; assess the health of deepwater coral species; and convert an oil well into an artificial reef. In addition, teams must prepare technical documentation for their vehicle, make a product presentation to a panel of judges, and create a marketing display.

This is the fifth year that the BHS ROV team has participated in the New England Regional ROV Contest, and the third year it has attended the MATE International ROV Competition. The team is supported by local sponsors, including Tom's Hobby Shop, East Bay Marina, and Schaumberg Electronics.

For more information about the BHS ROV team, please contact team marketing coordinator Jill Smith at (831) 555-1234 or [email@email.com](mailto:email@email.com).

For more information about the MATE ROV competition, visit [www.marinetech.org/rov-competition/](http://www.marinetech.org/rov-competition/) or contact Jill Zande at [jzande@marinetech.org](mailto:jzande@marinetech.org).

- ### -