

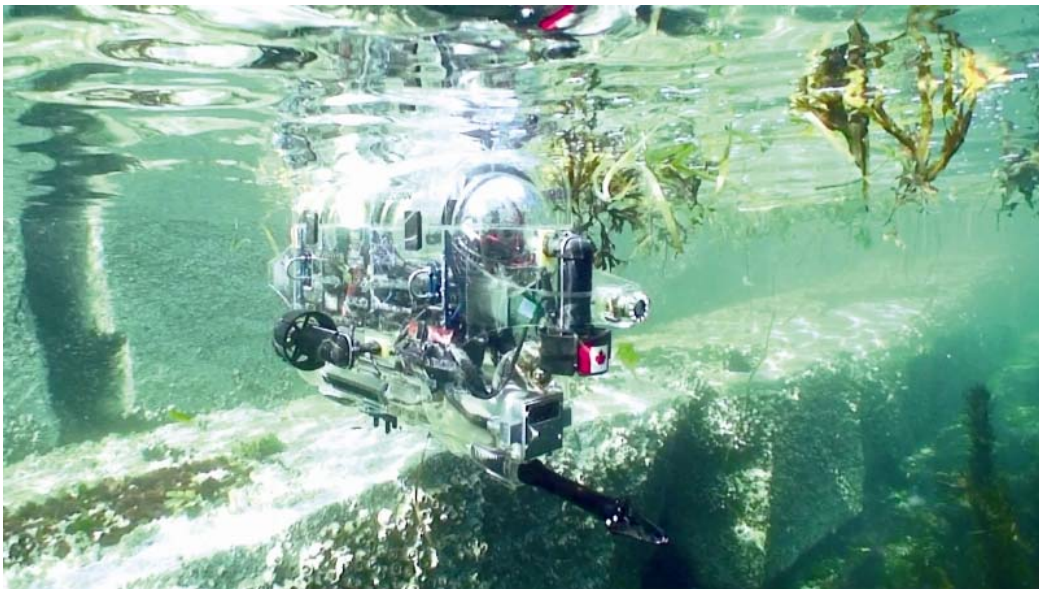

University of Victoria MATE Technical Report

Aerius
University of Victoria Unmanned Underwater Vehicle Team (AUVic)
Victoria, British Columbia, Canada
<http://www.auvic.uvic.ca/>



Matt Burdyny – *Project Director, Business Affairs, Mechanical Design*
Jamie Marshall – *Mechanical Design*
Ian Clark – *Software Design, Electrical Design*
Mark Butowski – *Software Design, Electrical Design*
Tony Kroeker – *Software Design*
Tyler Price – *Software Design*
Gabby Odowichuk – *Software Design*
Caleb Shortt – *Software Design*

ABSTRACT

This technical report describes the University of Victoria's remotely operated underwater vehicle for entry into MATE's 2008 ROV Competition. AUVic, the University of Victoria's underwater vehicle design team, is entering the competition this year for the second time.

This report details the mechanical, electrical and software systems that make up Aerius' overall design and functionality. It also details design challenges that were encountered and overcome during system integration, troubleshooting techniques and lessons learned during the design and testing of the vehicle, and future vehicle improvements. The report includes the team's reflections on the entire project, and an overview of the New Millennium Observatory, which uses ROVs to study mid-oceanic ridges.

Aerius consists of a flooded outer hull, and three dry inner hulls containing the batteries, electronics, and Doppler Velocity Log (DVL). Four Seabotix thrusters are employed to control the vertical and horizontal movement of the ROV. Also mounted in the submersible are the cameras, inertial measurement unit, pressure sensor, compass, active and passive sonar, grabber arm, and weight droppers.

The PC-104+ stack is the backbone of the ROV's electrical system. It contains two PCs, the fibre-optic board, Frame Grabber, Serial (RS232) modules, and the power regulator board.

In ROV mode, the software accepts velocity, heading and depth requests from the human operator and produces the desired results.

1. INTRODUCTION

A Remotely Operated Vehicle (ROV) is a submersible, tethered robot that is capable of performing complex tasks as directed by human operators. Unmanned submersibles are a very active area of research. Today's ROVs are

extremely versatile, with applications including underwater structure inspection and maintenance, submarine rescues, underwater manipulation, and aquatic sample collections.

This is AUVic's second entry into MATE's ROV Competition. AUVic is an Unmanned Underwater Vehicle (UUV) Design Team. The team's objective is to provide the vehicle with both ROV and AUV capabilities.

AUVic has made a substantial effort to develop a competitive product that can perform at an international level. In pursuit of the team's aspirations to build this vehicle, AUVic has made all efforts to acquire some of the most advanced technologies, integrated into an innovative new design. Through hard work and dedication, AUVic has significantly increased sponsorship, formed many corporate partnerships, and gained some of the most capable engineers of tomorrow.

2. MECHANICAL DESIGN

Aerius, shown in Figure 1, is designed to be ultra-compact and lightweight, while maintaining maximum versatility. Its overall size is 93cm x 48cm x 40cm. Its streamlined design allows for simplification and increased accuracy in the navigation algorithms.

The vehicle was designed to have a stable orientation in the water. The thrusters allow for pitch and yaw control while roll is controlled by the layout of the components. With heavy components such as the Doppler Velocity Log (DVL) transducer and sonar units at the bottom, and the buoyant battery and electronics hulls at the top, the vehicle will self-correct for any changes in roll.



Figure 1 – 2008 Aeriis design

The entire vehicle weighs 22.5 kg, and has been designed to be slightly positively buoyant. This has been achieved through engineering optimization and careful selection of materials. The outer and inner hulls have been precision molded using durable urethane. The aluminum components have all been CNC machined and anodized to create high quality sturdy components that are as aesthetically pleasing as they are functional. Where appropriate, delrin components have been integrated to reduce weight while maintaining the same functionality. The high precision of CNC machining and laser cutting allows for an extremely compact design with tight tolerances. The vehicle layout is such that all components can be accessed quickly and easily. Troubleshooting and maintenance is conducted with ease.

Aeriis is rated for a maximum depth of 300 meters. A theoretical rating was calculated using finite element analysis techniques in Solidworks, and subsequently verified by in-water testing in a pressure tank.

A. Outer Hull

Designed as a wet hull, it floods with water keeping the vehicle stable. It is molded from durable urethane, and wherever possible, incorporates mounting brackets and support structures directly into the outer hull. As a result, fasteners and small machined components are minimized, and unnecessary stress concentrations due to mounting holes are reduced.

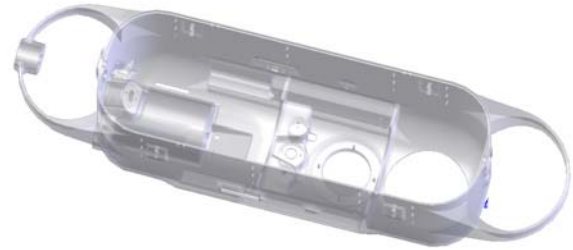

Figure 2 – Outer Hull (Bottom)

The top of the outer hull is a separate unit, and is held in place by four low-profile latches. This enables easy access to all components of the vehicle. The vehicle itself is very easy to assemble and maintain, due in large part to the careful design of the outer hull.

B. Electronics Hull and Battery Hull

The Electronics Hull and Battery Hull are both located at the top of the flooded outer hull. Much of the space inside these sealed hulls is filled with air, providing buoyancy to the vehicle. These components are precision molded from durable urethane, and are each sealed using a 6061 aluminum end-cap with two radial o-rings for a redundant seal. The cylindrical hull design allows them to withstand high water pressure without significant deformation.

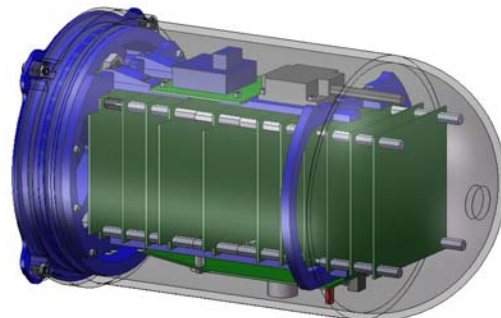

Figure 3 – Electronics Hull

The electronics hull contains the PCs and most of the electrical boards. Contents of this sealed hull include the compass, IMU (inertial measurement unit), sidescan sonar electronics, two PCs, power supplies, and PC104+ stack electronics. The electronics stack is mounted directly to the end-cap to simplify removal from the cylinder. When the end-cap is removed, all of the components come with it. One of the onboard PCs is a dual-core unit which produces significant heat. To counteract this heat

generation, a new innovative heat pipe used for military application has been mounted on the end cap, and a thorough heat transfer analysis in Solidworks has been performed to verify assumptions and calculations

The mounting configuration minimizes excess wires and cables. The stack can also be removed from the end-cap for maintenance. Four aluminum arms allow additional space for components to be mounted above and below the stack. The wires will run along both sides of the stack to the end-cap.

The electronics hull end-cap is equipped with Seacon connectors and a pressure relief valve for pressure equalization during assembly. The Seacon connectors allow power and control signals to be relayed between the inner hulls and to the rest of the UUV, and sensor data to be fed into the computer.



Figure 4 – Battery Hull

The battery hull was designed to contain OEM lithium-polymer cells from Emerging Power custom designed to form-fit the inside of this hull. However, due to last-minute changes to the MATE competition rules, these batteries have been removed and replaced with dead weight for the sole purpose of maintaining the ROV's proper orientation in the water.

C. DVL Hull

The DVL Hull is a watertight enclosure containing the DVL transducer and its electronics. Both the transducer and electronics are supplied by Teledyne RD Instruments. While this hull is sealed and contains buoyant air, this component is actually fairly heavy and is located on the bottom of the outer hull.



Figure 5 – DVL Hull

As with the other inner hulls, this component is precision molded from durable urethane, and the cylindrical hull design allows it to withstand high water pressure with minimal deformation. This component is designed to allow the electronics to be horizontal and the transducer to face downwards. As with the battery and electronics hulls, the horizontal end of the DVL hull is sealed using an aluminum end-cap with two radial o-rings for a redundant seal. The DVL transducer mounts directly to the bottom end, and seals using the transducer's three o-ring redundant seal.

The molded hull was designed to incorporate the mounting surface for the Applied Microsystems pressure sensor, and also includes flanges to mount securely to the outer hull.

D. Thrusters

There are four Seabotix 300 Watt brushless thrusters mounted directly to Aerius' outer hull. Two thrusters are mounted horizontally, one on each side, to provide forward and reverse motion. The remaining two thrusters are mounted vertically on the bow and stern of the submersible. They allow for depth control, and hold the positively buoyant vehicle below the water's surface.



Figure 6 – Seabotix Thruster

E. Grabber Arm

The grabber arm is mounted on the bottom front of the vehicle. It cannot move relative to the vehicle, so it is mounted at a downward angle. Positioning of the grabber claws is performed by adjusting the vehicle's orientation in the water.



Figure 7 – Seabotix Grabber Arm

F. Cameras

Three Inuktun Crystal Cams are mounted in specific locations on the vehicle. One camera is mounted on the front of the vehicle pointing forward. Another is located on the center of the vehicle's bottom surface, and is used for seafloor observation. The third camera is mounted on the front of the vehicle, but at a specific angle so as to view the grabber claws.



Figure 8 – Inuktun Crystal Cam

G. Weight Droppers

There are two weight droppers located on the bottom of Aeriis. They each use a permanent magnet to hold ball bearings in place. An electromagnet is used to negate this magnetic field, which releases the weights from the vehicle. One weight dropper is positioned on each side of the downward camera; this is to provide the best weight release location relative to the camera view.

H. Active Sonar

Multibeam and sidescan sonar units are recent additions to the vehicle. The active sonar system also includes the DVL. Since cameras have limited visibility underwater, the active sonar system was added to allow Aeriis to see accurately and many times further than any previous vehicle. AUVic is working to merge

sensor data from all three devices to create a virtual 3D image of the underwater environment. When this is complete, it will be possible to perform object detection and recognition.



Figure 9 – Multibeam Sonar



Figure 10 – Sidescan Sonar

I. Passive Sonar

The passive sonar housing is machined from delrin. It contains four Reson TC4013 hydrophones in a specific geometric configuration that allows for accurate three-dimensional locating of a sonar signal. The hydrophones are connected to a custom circuit board which then communicates to the rest of the vehicle using a single Seacon connector mounted on the top of the housing. A plastic guard protects the hydrophones from impacts.



Figure 11 – Passive Sonar

3. ELECTRICAL DESIGN

The PC-104+ stack is the backbone of the vehicle's electrical system. It contains two PCs, the fibre-optic board, Frame Grabber, Serial (RS232) modules, and the power regulator board. Figure 12 shows a schematic of the ROV's electrical systems.

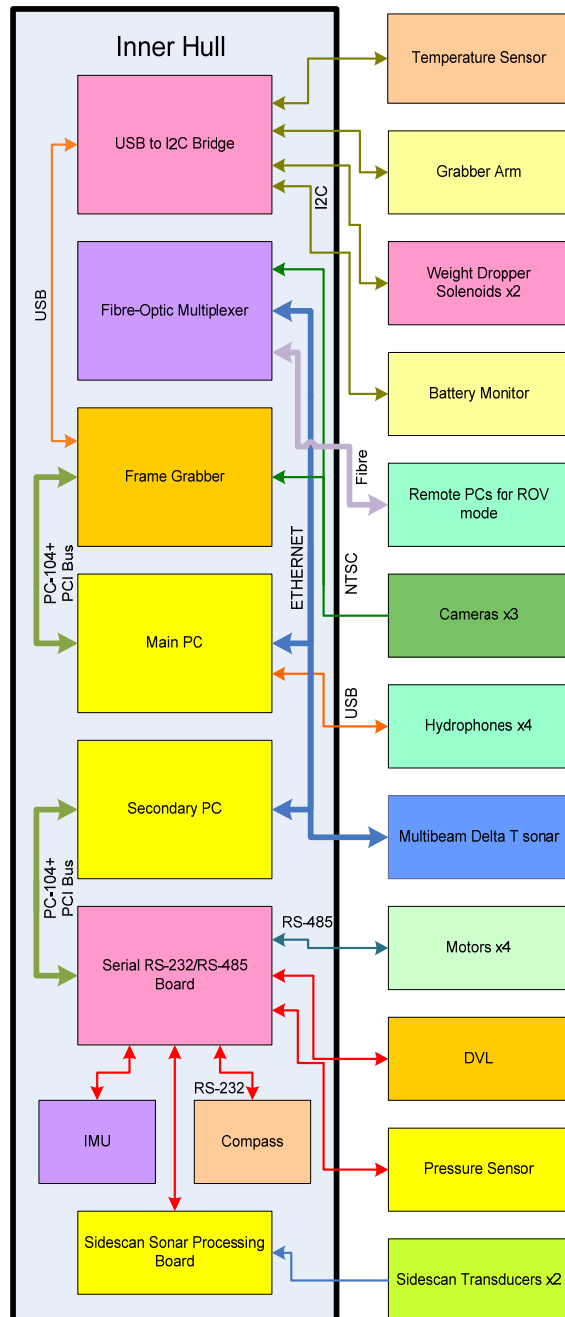

Figure 12 – Electrical Systems Schematic

A. PCs

There are two PCs inside the electronics hull. One PC is an ALD945 Intel Core2 Duo based system from Advanced Digital Logic. The second PC is an AMD Geode based low-power MSM800, also from Advanced Digital Logic. Both PCs follow the PC-104+ form factor, which allows many commercially available expansion cards to be stacked on top of one another and be connected by PCI bus. The frame grabber is stacked on the Core2 Duo PC, which provides the processing power for the vision software. The second PC runs the control and navigation software. It has the serial communications board stacked on it, which allows it to communicate with the sensors and thrusters. The operating system for each PC is installed on a 4GB compact flash card that is connected to the IDE port.

B. Thrusters

The Seabotix thrusters are controlled by RS-485. Each thruster has a unique address and only listens to packets that are meant for it. One of the outputs on the serial communications board is configured as RS-485 in order to interface the thrusters.

C. Batteries

The AUV is normally powered by 63 Emergent Power lithium polymer cells. The cells are arranged to be 9 in parallel by 7 in series. The cells are rated at 2100mAh and together provide around 18.9 Ah of life at approximately 30V. Since the vehicle uses approximately 3A of current when moving slowly, this allows for a running time of approximately 6 hours. An AT90USB-KEY mounted in the battery hull allows the battery voltage to be monitored, allowing approximate remaining running time to be estimated. The AT90USB-KEY controls the MOSFETS which cut off power to the connector if any cell's voltage is too low. Communication with the PC is done by I2C. Additionally, a fuse and current-leak detection are present for safety.

Due to last-minute changes to the competition rules, the battery pack will not be used for MATE. These battery modules have been removed and replaced with dead weight for the

sole purpose of maintaining the ROV's proper orientation in the water. Power will be provided from the surface through the tether.

D. Tether

Initial design for the vehicle was to use a single fibre-optic tether for communication, and the onboard batteries for power. Due to the last minute rule changes, an additional fused tether cable has been added to provide the ROV's electrical power.

The fibre-optic data tether is an armoured, neutrally buoyant, low friction, single-mode cable provided by Lancer Systems. It is connected to the rear of the vehicle and can be disconnected without removing the vehicle's lid. The tether is 300m long and approximately 6mm thick. The tether is wound around a slip-ring on the surface, allowing for easy tether management.

The vehicle's power tether is a 4-conductor 17-AWG (1.15mm diameter) water resistant cable. A length of 35m was chosen to be adequate for in-pool testing as well as for reaching all of the objectives in the MATE competition. (Non-competition ROV dives would normally use the batteries for power.) High-flexibility copper stranded wire was chosen to make the tether easy to handle and have low coiling torque on the vehicle. Two conductors carry the current in each direction.

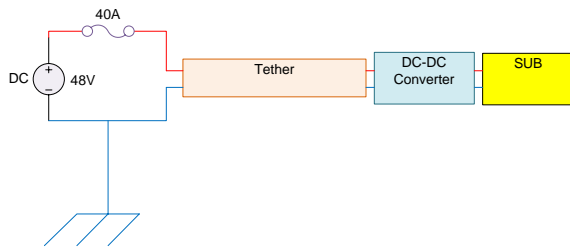

Figure 13: Grounded Fuse Safety Diagram

E. DC-DC Converter

When the vehicle is not being powered by batteries, the battery hull is swapped out for a hull containing a Lambda 750W DC-DC converter. This voltage converter steps down the 48V provided by MATE to 30V for the on-board electronics. Additionally, this prevents the

current-dependant voltage drop along the tether from affecting the voltage received by the electronics hull.

F. Fibre Optic Board

A pair of Focal 907 Video/Data multiplexers is used to stream all three analog video sources over the fibre-optic tether to the surface. One multiplexer is mounted on the top of the PC-104+ stack in the electronics hull, while the other is mounted in a topside enclosure. Each multiplexer has an add-on board attached to it acting as a 3-port + fibre switch, allowing both PCs and the multibeam sonar unit to communicate with a laptop computer on the surface.

G. Frame Grabber

The frame grabber captures images from the cameras, and digitizes them to allow for processing by the onboard vision system. Images from only one camera can be captured at a time, but the use of on-board multiplexing allows images to be captured from the various cameras almost concurrently, although at a lower frame rate.

H. Serial Board

The serial board is another PC-104+ stack module, which contains eight configurable RS-485/RS-232 ports. These ports are used to communicate with the various sensors and peripherals: the IMU, compass, pressure sensor, DVL, sidescan sonar as well as the thrusters.

I. Topside User Interface

The topside interface consists of a laptop pc, the second Focal 907 Board, a monitor and a manual video multiplexer. A 3DConnection SpacePilot 3D mouse is connected to the laptop for controlling the vehicle. The entire topside user interface is built into a Hardigg case for easy transport.

J. Temperature Sensor

The vehicle has a TI TMP275 I2C temperature sensor attached to the side of the manipulator. It is typically accurate to within 1/5 of a degree centigrade. The chip is waterproofed within a small epoxy enclosure.

K. USB to I2C Bridge

A second AT90USB-KEY is used as a USB to I2C bridge that connects the various I2C peripherals to the PC. Additionally, GPIO lines on the board are used to drive the MOSFETS that control the weight droppers.

L. Passive Sonar

A custom circuit board housed in the passive sonar housing processes the sonar signals. It connects to the main PC using USB.

4. SOFTWARE DESIGN

Aerius' software system is written primarily in Java and also features C and C++. As shown in Figure 14, the system is divided into several modules, which communicate over a TCP/IP based network server onboard Aerius.

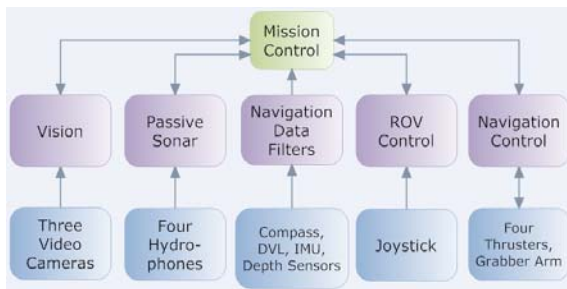

Figure 14 – Software Overview

The Mission Executer module coordinates the actions of Aerius based on inputs from the sensors. The Vision module provides relative azimuth and elevation suggestions as well as size approximations for each object detected to Mission. The Passive Sonar module provides the azimuth and elevations to a sonar beacon to Mission. In ROV mode, Mission is disabled and all control requests come from the user via the ROV client module.

The Navigational Data Filter receives data from Aerius' Compass, DVL, IMU and Pressure Sensor, and through a Kalman filter provides consistent and accurate data to both Mission and Navigation Control. Navigation Control implements a sliding mode controller, which receives data from the Data Filter, commands

from Mission or the ROV client, and actuates the thrusters to generate the desired motion. The ROV client is used for testing and Intelligent ROV operation of Aerius. Intelligent ROV operation allows the operator to combine the power of the navigational control system with the logic of a human operator.

A. ROV Client

Aerius' ROV client allows a human operator to direct the vehicle with the use of a USB 3D mouse. All communication requests are made possible through TCP/IP communication via a tether which connects Aerius' onboard computer to an onshore laptop.

The pilot can operate in one of 3 modes:

- “Direct Control” mode, where the sliding mode controller is bypassed, and the user's joystick is directly mapped to thruster power. This is beneficial in testing, and in situations where the navigational sensors fail or have reduced reliability.
- “Velocity Control” mode, where the user's input is mapped to requested velocities, and the sliding mode controller is used to attain them.
- “Position Control” mode, where the user specifies a desired destination, and the sliding mode controller brings the vehicle to that destination with no further input from the user. This is effectively an auto-pilot system.

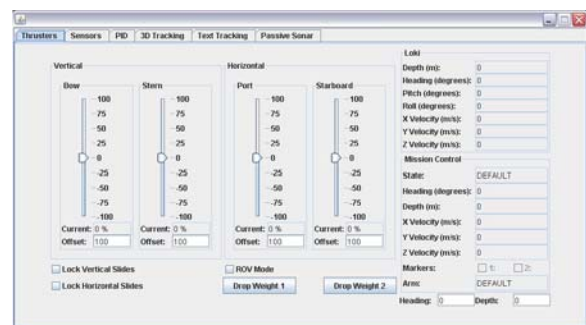

Figure 15 – ROV Client Interface

With the large amount of automation provided by the different control modes, the pilot is free to perform other tasks during the mission and can reduce fatigue on long distance missions.

B. Navigational Data Filtering

For Aeriis to navigate autonomously, the onboard navigation system must be able to determine the trajectory traveled from onboard sensor instrumentation only. GPS signals are not an option, as the carrier wavelength of a GPS signal is too short to penetrate far into the water.

The navigation hardware components on Aeriis include the IMU, DVL, digital compass and digital pressure sensor. Our system integrates the smallest hardware components currently available on the market in order to build a small, energy efficient vehicle.

The precision navigation system utilizes the IMU and is aided with ground velocity measurements provided by the DVL. Such a system is referred to as a “Doppler-Aided Inertial Navigation System.” A complementary software filter improves the gyroscope and accelerometer data, yielding more precise attitude estimation. Finally, a Kalman filter merges all sensor data together. The application of the Kalman filter creates smoother and more stable data estimation, which facilitates accurate knowledge of the vehicle’s position and attitude.

Kalman filters are employed when data from different sensors have to be merged in order to maintain high precision navigation. Sensors like the DVL have a limited update rate, which is usually in the range of 1 to 10Hz. The higher the update rate of navigation instrumentation, the more precisely navigation can be achieved. The Kalman filter estimates the gaps between the DVL readings, and produces a higher, “artificial”, update rate. In conjunction with CSSF (Canadian Scientific Submersible Facility), a navigation system has been developed specifically for the Aeriis utilizing a complementary filter for orientation, and a Kalman filter for positioning and attitude.

C. Thrusters and Manipulator

Aeriis’ lowest level of software operates the thrusters and manipulator. This software is responsible for translating thrust levels and grabber commands into electrical signals. Aeriis communicates with the thrusters through RS-485. It periodically polls the status of the thrusters, and checks for stalls, water leaks, and overheating. If it detects an error, a warning message is issued to the onboard computer and the appropriate actions are taken to ensure the safety of the vehicle and its operators. The Seabotix grabber arm is controlled through the I²C protocol. This protocol was used due to its simplicity and compatibility with Seabotix’s devices.

D. Vision

The vision system can be broken into three parts: data collection, transmission/decoding, and analysis. The data is collected by three Inuktun Crystal Cams. Each of these cameras outputs a NTSC signal, with 480 TV lines of resolution. One of the cameras points forward, the second camera points directly downwards, and the third camera is used to coordinate any grabber arm activity.

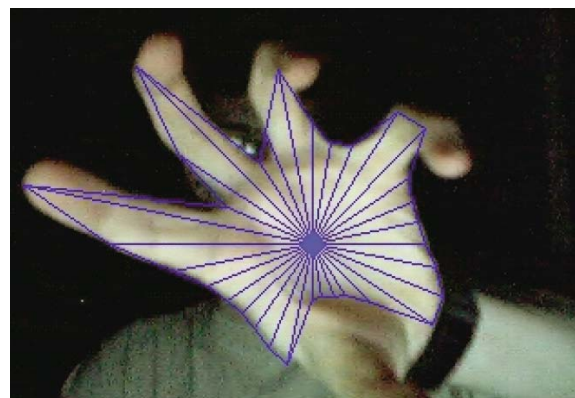

Figure 16 – Vision

The video from these cameras goes to a CM7326/CM7327 Frame Grabber module, from RTD Embedded Technologies, Inc. This board is located on the PC-104+ stack, and converts the NTSC analog signal to a digital signal that can be processed by the Vision software. Additionally, both the analog and digital video signals from the cameras are sent to the surface over the tether.

The analysis of the data is one of the most crucial areas of this process. A Vision server thread is always running on the vehicle in AUV mode, and can provide appropriate directions or headings to Mission when called upon. Vision performs an analysis on each image, and returns the results to Mission. Results include information such as a heading to the detected buoy or pipe. Mission can then instruct Navigation to adjust to this new heading. This process is executed periodically.

The digital image processing takes three steps.

1. HSL or RGB, high and low boundaries are chosen from a list of presets. At this time, the appropriate secondary analysis is also chosen. Both of these cases are dependent on prior calibration. This allows the Vision module to run specific algorithms for each portion of the course.
2. The program scans through the image once, creating polygon approximations around the areas that meet the HSL criteria.
3. Two processes (A & B) can now occur in parallel.
 - A) The polygons are analyzed according to the secondary criteria, and return data to navigation. Sometimes data will only be returned once several frames have been processed. (Flash rates, double checking, averaging, etc.)
 - B) At this point new image data can be loaded in from the camera(s), and will be ready for the next analysis. The current frame of pixel data can be overwritten, because the polygons encompass all the data that is needed for the secondary analysis.

E. Passive Sonar

Sonar is an important localization tool for any underwater vessel. Sonar is classified as either active or passive: active sonar transmits a signal and receives a reflected version of that signal;

passive sonar receives signals transmitted from an outside source.

The vehicle's passive sonar system receives underwater signals between 20 and 40 kHz from a predefined source. It will determine the azimuth and elevation to the transmitter.

The signal is received by an array of four hydrophones, converted to digital data and processed by an embedded digital signal processor. The array is an Ultra-Short Baseline (USBL) one, where the spacing of the hydrophones guarantees there is no phase ambiguity. The phase difference between the signals received by each hydrophone is converted to a time difference of arrival. The time difference and the geometry of the array are then used to find the direction to the transmitter. This method is well established and has proven to be a robust solution that can operate effectively in high noise environments.

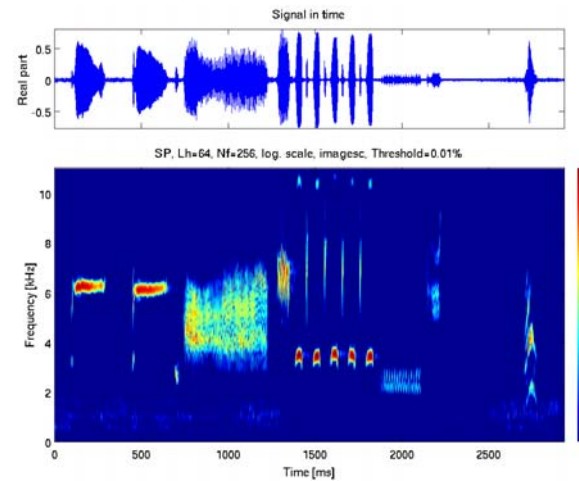

Figure 17 – Passive Sonar Spectrum

The passive sonar system is designed as a DSP solution. This means that the input signals from the hydrophones are immediately digitized, then stored in buffers and manipulated in software. This method has been chosen because it is simple in terms of hardware and because parameters and algorithms can be easily adjusted in software.

The passive sonar system is designed in-house. A single board solution was developed where four charge amplifiers pre-amplify the

hydrophone signals, an AD1974 192kHz 24-bit analog-to-digital converter samples the amplified signal, and an ADSP-21262 200Mhz 32-bit floating-point digital signal processor runs ping detection and phase difference estimation algorithms.

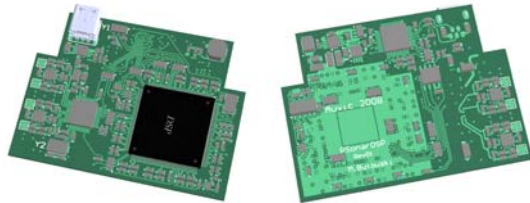

Figure 18 – Passive Sonar Board

F. Navigation Control

The system was initially designed in Matlab, to determine stability characteristics. Afterwards, it was ported to the Java framework and refined on live hardware.

The control system comprises of four modules:

1. A dynamics model for the vehicle, where mass, drag, Coriolis effects, and gravity are simulated to compute the expected motion of the vehicle.
2. A sliding mode controller minimizes the error between desired action and that seen by the Navigation Data Filters module.
3. A thrust mapper maps desired forces and moments acting at the centre of mass of the vehicle to the four thrusters.
4. A thruster control module to produce the thrust. The module uses independent PID loops around each thruster to maintain the desired RPM. A thruster characterization was performed to determine the force provided by any thruster at several propeller velocities.

G. Mission

The Mission module is at the highest level in the software hierarchy, coordinating the global state of the submarine and the state of each subsystem. It makes calls to Vision, Sonar, and Navigation to dictate how each portion of the

course is carried out. The mission software comprises of a main mission class and individual tasks for each mission objective.

Mission tasks are constructed as a finite state machine. The state machine controls the mode of each module, which in turn controls what data is returned from these modules. It takes data from the vehicle's subsystems and returns navigational requests, telling the sub where and how to move. Each task will return one of three possible outcomes for the objective: "completed successfully", "not completed", or "timed out".

The main class executes smaller tasks, determining the order in which tasks are attempted based on previous outcomes. The clauses in mission will determine if a task should be re-tried, and which task should follow a successful or failed execution. This results in an intelligent solution in which the submarine is able to make decisions and recover from errors.

5. DESIGN CHALLENGES

Aerius' control and navigation system obtains its abilities from the diversity of software and electrical sub-systems on board. However, in order for Aerius to operate at her peak, each of these subsystems must be able to communicate and work together effectively and efficiently. With system integration often being the most technically demanding and error prone process in the design and construction of an underwater vehicle, the issue was addressed in three phases: technical specifications, implementation, and system evaluation and modification.

The technical specifications were defined by several of AUVic's most involved programmers and electronics specialists to ensure compatibility between all subsystems. The process was started by creating a list of requirements and their relative importance as shown below.

1. *System Reliability* – No single subsystem can crash another subsystem.
2. *Communication Speed* – Large amount of data can transfer quickly.

3. *Information Relevance* – Subsystems receive only up-to-date data.
4. *Standardization* – Communication Protocol available to all systems.
5. *Ease of Implementation* – Ability to be implemented in many programming languages.

These requirements and the power of Aeri^{us}' onboard computer led to the decision of using TCP/IP network communication as the backbone with RS-232 being used to communicate with the lowest level of hardware. TCP/IP provides proven high speed, standardized error-corrected communication, and while RS-232 is not as reliable or high speed, it performs well in embedded applications due to its low overhead and extensive history of use.

With the requirements determined, AUVic's software team reviewed the existing subsystems and designed a solution. The solution used TCP/IP and RS-232 as required while ensuring that the most current information was easily available to each subsystem and its programmer. Aeri^{us}' software team started by building a network server that could receive and transmit data to and from each subsystem. The server was created in Java to ensure rapid development and was designed to only pass data between subsystems, thus not parsing data and increasing transmission speed. Once the server was created, a network client framework was developed for Java, C and C++ to allow all subsystems to communicate with the server.

The network client for Java was created with very few problems due to the high level approach Java takes. Unfortunately, the C and C++ network clients provided a larger challenge due to the complexity of network programming and file parsing in each respective language. However, through review of technical books and with the assistance of other programmers, the framework was created for all three languages.

Once all systems were created, the communications were tested. Several issues were detected relating to system stability and individual clients' ability to slow the whole

system down. However each issue was solved in turn with small modifications to the code.

The complex and potentially error prone challenge of integrating Aeri^{us}' many subsystems was overcome. This was achieved through a defined design process and an organized testing strategy. Moreover, through effective team collaboration, all requirements were fulfilled by the final solution.

6. DESIGN RATIONALE

To complete the tasks, the vehicle has been outfitted with several additional sensors and capabilities. The tasks will be accomplished as follows:

Task #1 – The vehicle is equipped with two horizontal facing and two vertical facing 300 Watt thrusters that provide 37 Newtons of force each; this offers ample force to move and free the OBS even if ALL eight of the two pound weights remained on the OBS through the surfacing process.

Task #2 – The vehicle is equipped with a manipulator to acquire the two pound weights through a clamping force with overlapping teeth, similar to fingers when hands are clasped. This operation will be performed three times to retrieve the weights. With the help of intelligent navigation and control systems, this process will be completed with autonomous autopilot assistance.

Task #3 – Lastly, the vehicle is equipped with a custom temperature sensor. It is attached to the forward most tip of the manipulator. The plan is to drive the vehicle's manipulator tip into the hot stream of the hydrothermal vent and acquire an accurate temperature reading.

The execution of the tasks will continue to be tested leading up to the competition. This will hone and optimize mission times and performance.

7. LESSONS

Over the past years, AUVic's team members have learned valuable lessons, and gained many new skills. In particular, AUVic has learned one very important lesson regarding the value of using off-the-shelf components wherever possible. The recent re-design of AUVic's vehicle was an ambitious project as a whole, and much more so with the choice to design and manufacture thrusters from scratch.

The thrusters consisted of Maxon brushless motors, sealed inside a lightweight CNC machined aluminum enclosure. Custom motor-controllers fit within the thruster housings, and attached directly to the motors. This was to save space within the sealed electrical hull, reduce the number of wires going to the electrical hull, and to isolate the vehicle's electronics as much as possible from noise generated by these motor controllers.

While this seemed like a good idea at the time, many problems were encountered with the custom motor controller electrical boards.

The motor controllers consisted of three 4-layer 30mm diameter electrical boards, stacked on top of each other. A considerable amount of electronics was to be fit in a very small space. Problems were first encountered during assembly. Two capacitors turned out to be much larger than specified, and did not fit well between the boards. Space was already very tight within the thruster housings, but with a bit of work, the components were adjusted to accommodate for the extra space required.



Figure 19 – Custom Motor Controllers

The considerable time required for assembly of the boards and for the subsequent troubleshooting was not accurately anticipated. The completion of the thrusters system took much longer than anticipated, and put the team behind schedule.

While on site at a competition, the motor controllers started working intermittently, and then proceeded to fail completely. Over the course of the next three days, the team devoted themselves to repairing the boards so AUVic could compete successfully, but to no avail. Two boards were thought to be repaired, but these failed again on subsequent competition runs.

When designing such a complex system, problems are expected. Because the entire vehicle is essentially a first prototype, but is required to be fully functional, it must be designed very carefully so that no major problems are encountered that cannot be easily fixed.

The major problem with the motor controller electrical boards was that too many electrical components were located in too small a space. The tolerances on the electrical boards were so tight that it was difficult to properly solder the components. The design was faulty in that it was simply too difficult to populate, and this was

something that could not be remedied except with completely new motor controller boards.

After the experience with the motor controllers, the custom thrusters were completely scrapped. These were replaced with Seabotix thrusters, which were integrated into the vehicle soon after they arrived. The Seabotix thrusters are an off-the-shelf solution; therefore, minimal testing was needed, and minimal troubleshooting was required for their implementation.

These problems with the motor controllers severely hurt AUVic's standings during that competition, but a valuable lesson was learned. To avoid such problems in the future, off-the-shelf components will be used wherever possible. This saves design and implementation time, and most importantly, the individual system works before it arrives, and the only work required is integration with the vehicle.

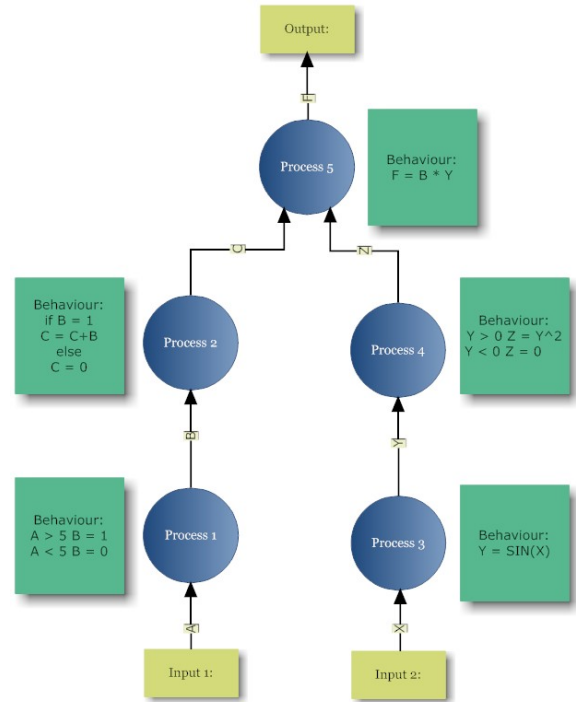

Figure 20 – Example System Diagram

8. TROUBLESHOOTING TECHNIQUES

In encountering any problem, especially a technical problem, a systematic and thorough approach is beneficial. The problem solving approach used by AUVic is based on a top down analysis. To perform a top down analysis one must break down the operation of a malfunctioning system into sub-systems. Each sub-system should be organized in a parent-child tree so inter-system dependences can be observed. Once each sub-system is identified, its expected behaviour and response to input must be specified.

Starting at the bottom-most child of the system, the behaviour of each node should be verified by applying a known input. If an error is detected, the sub-system should be broken down into more sub-systems if applicable and the process repeated. As each sub-system is verified you can move up the parent-child tree and verify the next sub-system until the problem is found. In the case when two or more branches intersect, each branch of the tree should be verified separately before the intersecting parent node can be verified.

In large scale systems this approach can become very confusing and time consuming if not documented properly. To solve these problems the AUVic organization creates system diagrams during development which can be referenced at the time of debugging, such as the diagram in Figure 20.

A top-down analysis is often a time consuming processes however with proper documentation it produces efficient, consistent and accurate results.

9. FUTURE IMPROVEMENTS

AUVic has ensured Aeriis is well equipped for all situations it may face. Even with its large array of instrumentation and sleek body, there are a few changes planned for Aeriis in the future. These improvements include further development of its Active Sonar systems, increased navigation accuracy, and increased manipulation capabilities.

In the current design for Aeriis, when the vehicle speed is abruptly changed, the vehicle rocks forward and backward before settling into a steady position. This is due to location of the two forward facing thrusters in relation to the vehicle's centres of mass and buoyancy. During the next redesign of Aeriis, this design flaw will be addressed. It cannot be altered at present due to the complexity of the overall vehicle design, as the positioning of many other components would have to be adjusted at the same time. The outer hull will also have to be modified. Repositioning the motors is not feasible with the current vehicle layout, and will be addressed in the future.

10. REFLECTIONS

This project has introduced AUVic team members to the marine industry and has allowed them to gain vast amounts of knowledge within this complex area. These connections and support from the industry have led to coop/internship placement for many of the students at some of the leading marine companies from around the world. This experience has allowed AUVic members to work hands on with a quality product and industry instrumentation making members an excellent asset to any marine-based company.

It is through these experiences and efforts that AUVic competed in the Canadian Engineering Competition. The team's efforts resulted in a first place win and a special award for Technical Excellence. With these achievements AUVic has been featured in newspapers, radio and television stations across the country, some of

which include CBC, the Vancouver Sun, and the Times Colonist. In addition, AUVic was featured in an episode of "Leading Edge: Innovation in BC" aired on the Knowledge Network in January.

Aeriis is the product of the team's collaboration and hard work. AUVic members stand proud as the creators of Aeriis, but as always are excited for continuing progress and improvements on the vehicle.

11. NEMO & THE AXIAL SEAMOUNT

Oceanic ridges form a 75,000 kilometre underwater mountain chain, and are some of the steepest formations on earth. Parts of the ridges are up to 3 kilometres high. Midoceanic ridges parallel the coastlines and separate the ocean floor between continents into almost two equal parts. These underwater mountain ranges mark the boundary between two tectonic plates. New ocean floor crust is created in the rift valley, which runs down the center of the ridge. This is a weakness in the ocean's crust, and magma rises through it forming new crust when cooled (Figure 21). The new crust pushes the old crust away from the rifts, causing a spreading action at the ridge. Shallow earthquakes and high temperature heat flows are common. [1] [2]

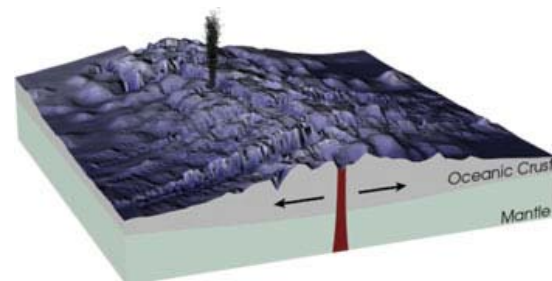

Figure 21 – Midoceanic Ridge [2]

NeMO, which is the New Millennium Observatory, is a "long term study of the interactions between geology, chemistry and biology on a dynamic part of the mid-ocean ridge system, using state-of-the-art technology." [3] Many observations will be taken at one specific location over a span of several years. The objective of this project is to document the

changes occurring in the various natural systems in this location. As a result, a multi-year sea floor observatory was established at the Axial Seamount on the Juan de Fuca Ridge. Historically, this volcano is the most active on the Juan de Fuca Ridge. The Axial Seamount is located roughly 400 kilometres off the Washington and Oregon coasts, and it lies 1.5 kilometres under the ocean's surface. Figure 22 shows a diagram of part of the equipment layout at the Axial Seamount. [3]

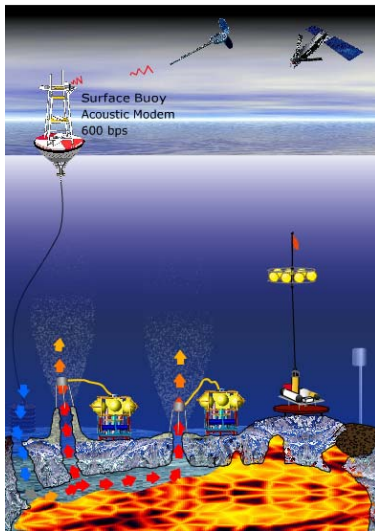

Figure 22 – Instruments at the Axial Seamount Site [3]

Many different tools and technologies have been employed in the NeMO project, but the ROVs ROPOS and Jason have played instrumental roles. ROPOS is operated by the Canadian Scientific Submersible Facility (CSSF), which is a non-profit corporation. [4] Jason is operated by the Woods Hole Oceanographic Institute (WHOI). WHOI is “the world's largest private, nonprofit ocean research, engineering and education organization.” [5]

ROPOS (Figure 23) has performed numerous vital tasks for the NeMO project over the ten years the project has been underway. Every cruise with the exception of 2005 has utilized the ROV ROPOS. The ROV Jason (Figure 24) was only used in the most recent cruise to the Axial Seamount.



Figure 23 – The ROV ROPOS [4]

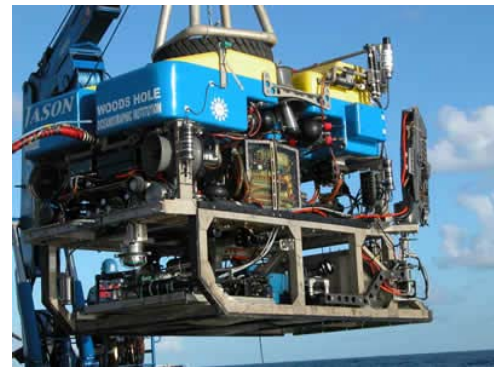

Figure 24 – The ROV Jason [3]

In 1999, ROPOS recovered more than 260 geologic, biologic and chemical samples, deployed 25 experiments, and recovered 29 experiments and instruments that had been deployed in 1998. [3]

During the 2000 cruise, ROPOS stopped at hydrothermal vents to recover and set up temperature sensors. It retrieved instruments to download the data collected during the past year. Precision lasers on ROPOS were used to take measurements of the size and spacing of lava crusts located on the lava pillars. These measurements were then compared to computer models of lava crust formation. [3]

In 2001, ROPOS visited all the extensometer instruments, took pressure readings, and downloaded data from each of the instruments. ROPOS recovered and deployed temperature sensors from two hydrothermal vents, one of which showed changes consistent with small earthquakes. A precision sensor on ROPOS was used to make measurements in and around the caldera of Axial volcano, as well as a nearby lava flow. Images of lava pillars were collected,

and the ROV's lasers were used again to accurately measure the size of the crusts on the lava pillars. [3]

During the 2002 cruise, 84 samples were collected, and many instruments were recovered. One such instrument was located at a hydrothermal vent and had been collecting one water sample each week for the past year. Bacteria traps were also recovered. [3]

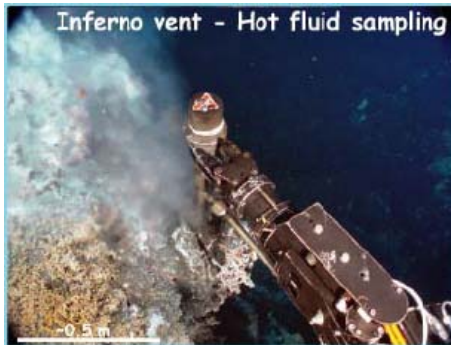

Figure 25 – Hot Fluid Sampling at a Hydrothermal Vent [3]

In 2003, 2004 and 2006, similar tasks were again performed by ROPOS. But in 2006 ROPOS's heavy lift capability was required to recover a Volcanic System Monitor, which includes sensors that record volcanic shaking. [3]

In 2007, two ships cruised to the Axial Volcano site, and each one was equipped with an ROV. ROPOS was again present, as well as a new ROV, Jason. This enabled more work to be accomplished and more ground covered in the same amount of time. [3]

The use of ROVs has been crucial to the NeMO project. Many of the dives have been to high temperature, dangerous areas. Using ROVs has eliminated the need for divers, which would be very much at risk in the environments important to the NeMO project. Divers are limited in the amount of time they can spend underwater, and the ROVs were diving regularly for up to 16 hours each day. This is much more than a diver could safely do, which means multiple divers would have been required to perform the same tasks. This would become very expensive. Many of the dives were in poor and dangerous conditions near hydrothermal vents and

underwater lava flows. Taking fluid samples from a vent with water temperatures above 200°C to 300°C could only be accomplished by a machine. ROVs can also capture images and video while performing other tasks at the same time.

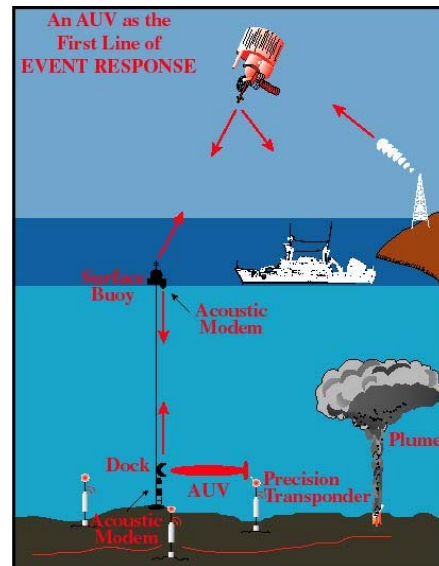

Figure 26 – AUV Rapid Response [3]

NeMO is a long term undertaking, and there are ambitious goals for the future. The events occurring mere days and weeks after a volcanic eruption are when the most interesting changes occur in the environment near the volcano. However, the volcanic activity is erratic and unpredictable. Therefore, the goal is to establish a “first response” system at Axial Volcano to collect important data in the event of an eruption. It is impossible to launch a ship and travel to the site in time to monitor the eruption and subsequent changes, therefore a suite of monitoring instruments permanently located at the site, as well as an AUV which would be launched immediately following an eruption. [3]

12. ACKNOWLEDGEMENTS

AUVic would like to thank all those involved with the team, and all those who have contributed to its success. Each and every individual has made a difference in the output of the end product, and AUVic thanks you all. The

following people have been invaluable resources for AUVic.

Thank you to:

- Dr. Michael Miller – Dean of UVic Engineering
- George Csanyi-Fritz – Faculty of Engineering (UVic)
- Dr. Brad Buckham – Department of Mechanical Engineering (UVic)
- Maria Lironi – UVic Communications
- Ray Brougham – Prototype Equipment Design
- Kory Pollner – Prototype Equipment Design
- Dean Steinke – Dynamic Systems Analysis
- Harry Maxfield – Teledyne RD Instruments
- Gina Lopez – Teledyne RD Instruments
- Omer Poroy – Teledyne RD Instruments
- Randy Marsden – Teledyne RD Instruments
- Paul Devine – Teledyne RD Instruments
- Jeff Lemker – Solid Concepts
- Scott Lubel – Solid Concepts
- Mark Reibel – Solid Concepts
- Scot Thompson – Solid Concepts
- Gary Karns – Advanced Digital Logic
- Dieter Beck – Advanced Digital Logic
- Martin Mayer – Advanced Digital Logic
- Chris Roper – Roper Resources
- Robin Kent – Hardigg Cases
- Dr. Roberto Racca – Jasco Research Limited
- Steve Koepenick – SPAWAR Systems Center
- James Buescher – SPAWAR Systems Center
- Darryl Davidson – AUVSI
- Dave Novick – AUVSI
- Angela Carr – AUVSI
- Gretchen Wherry – AUVSI
- AUVSI Competition Judges
- Jill Zande – MTS MATE
- MTS MATE Competition Judges
- Office of the Dean of Engineering

13. SPONSORSHIP

AUVic would like to send out a special “thank you” to all its sponsors, as they have made this project possible and have enabled the students at the University of Victoria to take part in an amazing educational endeavor. Due in no small part to all the sponsors’ generous contributions, this organization has been able to build a world-class competitive vehicle.

Many thanks to:

- University of Victoria – Faculty of Engineering
- Teledyne RD Instruments
- Solid Concepts
- Seacon Connectors
- Emerging Power
- Falmat
- Lancer Systems
- Prototype Equipment Design
- Imagenex
- Focal Technologies
- Sparton Electronics
- Seabotix
- Canadian Scientific Submersible Facility (ROPOS)
- Engineering Students Society
- Westmar
- Dynamic System Analysis
- Inuktun
- 3D Connexion
- Ocean Server
- Altech Anodizing
- Aqua Lung
- BMT Fleet Technology
- Princetel
- Pelcian Cases
- IGUS
- Logitech
- International Submarine Engineering
- ORE Offshore
- Great Ocean Adventures
- Deepsea Power and Light
- Roper Resources
- Jasco Research Limited
- NSERC
- Kongsberg
- Oceanworks International
- XS Scuba
- Bare
- Engineered Syntactic Systems
- Teleflex Marine
- Hardigg Cases

14. CONCLUSION

Aerius, AUVic's 2008 unmanned underwater vehicle, is a considerable improvement over previous vehicle models. This year's submersible is the third version in an iterative design process, and has improved ROV capabilities over last year's model. Complements of our sponsors, AUVic was able to integrate some of the world's most technologically advanced instrumentation onto an ultra-compact unmanned underwater vehicle. In conjunction with our partnering sponsors, the University of Victoria has been able to create its finest vehicle ever.

15. AUVIC TEAM MEMBERS

The AUVic design team includes students with expertise in Mechanical, Electrical, Computer and Software Engineering, as well as Business Administration. The core members of AUVic are:

Matt Burdyny – *Project Director, Business Affairs, Mechanical Design*
Jamie Marshall – *Mechanical Design*
Ian Clark – *Software Design, Electrical Design*
Mark Butowski – *Software Design, Electrical Design*
Tony Kroeker – *Software Design*
Tyler Price – *Software Design*
Gabby Odowichuk – *Software Design*
Caleb Shortt – *Software Design*

16. REFERENCES

- [1] <http://www.cliffsnotes.com/>
- [2] <http://www.wikipedia.org/>
- [3] <http://www.pmel.noaa.gov/vents/nemo/>
- [4] <http://www.ropos.com/>
- [5] <http://www.whoi.edu/>

APPENDIX I
BUDGET

Vehicle Components

Sensors

Doppler Velocity Log	\$25,000
Inertial Measurement Unit	\$12,500
Magnetic Compass/Gyro	\$1,250
Pressure Sensor	\$3,500
Hydrophones (4)	\$4,800
Underwater Camera's (4)	\$7,000
Side scan sonar	\$5,500
Multibeam sonar	\$35,000

Electronics

Primary Core Duo PC104+	\$2,500
Secondary Geode PC104+	\$500
Com port board - PC 104+	\$350
Frame grabber - PC 104+	\$500
Power supply - PC 104+ (2)	\$1,400
Fiber Optic Conversion board - PC104+	\$4,000
Fiber Optic/Electrical Slip ring	\$4,000
Custom HUB board - PCB	\$500
Test Range Blinker - PCB	\$350
Wiring - Cables	\$150
Electronic Components	\$1,000

Mechanical

Underwater Connectors/Cable Assemblies	\$15,000
Fiber Optic Tether/Connectors	\$5,000
Brushless Thrusters (4)	\$5,000
Grabber Arm	\$2,000
Pressure Relief Valves	\$1,250
Urethane Casts - hulls	\$20,000
Materials	\$1,000
Machining	\$2,500
Anodizing	\$50
Hardware and Fasteners	\$100
Vehicle Stand	\$100
Flootation	\$500

Other

Vehicle Case	\$1,500
Sponsorship Decals	\$500

Total Vehicle Components \$156,300

Team Costs

Team transportation costs	\$1,000
Team Hospitality	\$500
Sponsor Hospitality	\$750
Corporate Visits	\$5,000
Sponsorship Costs	\$500
Pool Tests	\$1,500
Promotional Material	\$2,500
Phone, Phone Setup, Long Distance Bills	\$750
Competition Registration Fees	\$750
AUVSI/ONR AUV Competition Travel	\$10,000
MTS MATE ROV Competition Travel	\$5,000

Total Team Costs \$25,250

Total Costs

Vehicle Costs	\$156,300
Team Costs	\$25,250
Shipping and Customs Costs	\$1,000

Total Project Costs \$182,550

Revenue

Grant Allocations	\$15,000
Component Sponsorships	\$135,000
Financial Sponsorships	\$32,500
Prize Money	\$2,500

Total Project Revenue \$185,000

Please note due to confidentiality agreements with corporate partners, individual sponsorship amounts may not be disclosed.

APPENDIX II
TOP-SIDE CONTROL FLOWCHART

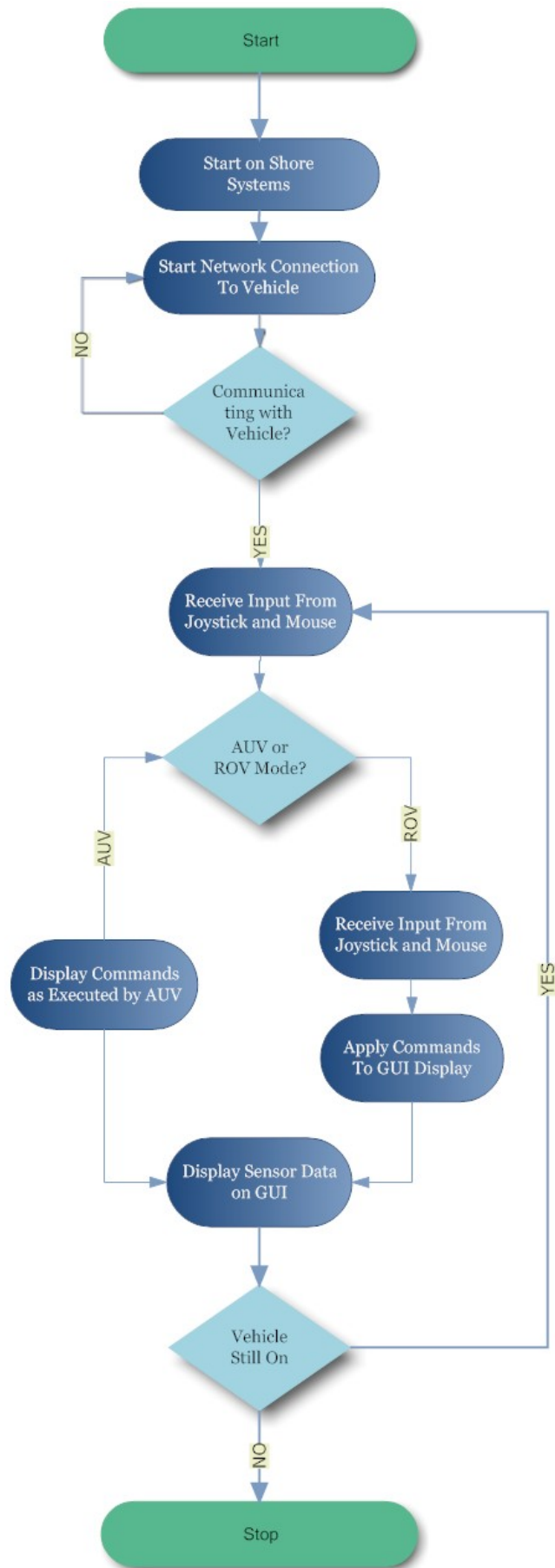

APPENDIX III
BOTTOM-SIDE CONTROL FLOWCHART

