

# The British Columbia Institute of Technology Underwater ROV System



## **Team members:**

Peter Zielke, Fazmin Mohamed (Frame and Propulsion)

Andy Io, Wesley Fan (Control system)

Wolf Tivy, Omar Suleman (Tool System)

All team members expected to graduate from BCIT Mechanical Design  
Technology June 2009

**Sponsor:**  
Taco Niet

**Abstract:**

The BCIT ROV was designed for the MATE 2009 international ROV competition. The goal of the design was to be as elegant as possible with minimal waste.

The design includes 5 Seabotix thrusters giving four degrees of freedom. Four of the thrusters are mounted around the perimeter for horizontal motion. The other thruster is mounted vertically in the centre of the ROV for vertical movement.

There is no separate frame; instead all components mount to a central pressure hull inspired by real submarine rescue vehicles.

For tools, the ROV has two simple multipurpose manipulator arms made from sheet metal and coat hanger wire. The tools are general in ability but are optimized for the competition tasks.

The ROV is controlled by software on three Atmel AVR microcontrollers. One microcontroller sits on the surface to get user input and communicate with the other two, which are onboard the ROV. For sensors, the ROV supports up to four cameras, but is currently using only three.

## Table of Contents:

<b>Introduction</b>	<b>2</b>
<b>The Remora Submarine Rescue Vehicle</b>	
<b>Design Considerations</b>	<b>3</b>
• <i>Overall Design Goals</i>	
• <i>Frame</i>	
• <i>Stability and Buoyancy</i>	
<b>Design Overview</b>	<b>4</b>
• <i>Subsystems Outline</i>	
• <i>Propulsion System</i>	<b>5</b>
• <i>Pressure Hull</i>	<b>6</b>
• <i>Tool Module</i>	<b>7</b>
• <i>Camera System</i>	<b>9</b>
• <i>Tether</i>	
• <i>Surface station</i>	
• <i>Assembly Details</i>	<b>10</b>
<b>Control System Details</b>	<b>11</b>
• <i>System layout</i>	
• <i>User Interface Module</i>	
• <i>Tool Control Module</i>	<b>12</b>
• <i>Thruster Control Module</i>	<b>13</b>
<b>Challenges and Troubleshooting</b>	<b>13</b>
• <i>Control Meltdown</i>	
• <i>Floatation</i>	<b>14</b>
• <i>Tool Design Iterations</i>	
<b>Scheduled and Hypothetical Changes</b>	<b>14</b>
• <i>Tether Optimization</i>	
• <i>Floatation Rebuild</i>	
• <i>Lighter Cameras</i>	<b>15</b>
<b>Project Budget and Expenditures</b>	<b>15</b>
<b>Reflections</b>	<b>16</b>

## **Introduction:**

For the 2009 MATE international competition, British Columbia Institute of Technology is entering an explorer class ROV. The BCIT ROV is made entirely from scratch by students. The project started in January with no previous ROV or any design plans; the team went through a comprehensive design process to come up with a simple and effective ROV design. Six students are involved in the project, all in the mechanical design technology program at BCIT.

This report describes the BCIT ROV design, a real life submarine rescue ROV system, and the experience that the team has gained as a result of the project.

## **The Remora Submarine Rescue Vehicle:**

North Vancouver, BC based Nuytco Research Limited is a leading edge underwater technology company that focuses on the development and implementation of undersea technologies. Several members of the BCIT ROV team went to the OceanWorks International shop (previously Hard Suits Inc.) and had a chance to see some of their products being manufactured.

Dr. Phil Nuytten, the president of Nuytco Research limited, developed a rescue/intervention system called the Remora in the 1990's. Some of the main design features of the Remora included a converted diving bell and two swivelling connections on the mating skirt which allowed for connections at angles up to 60 degrees. Figure 1 below shows a conceptual image of the Remora and its mating skirt:

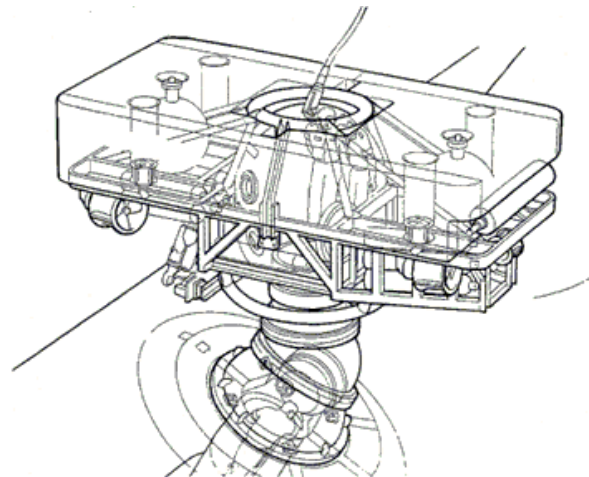

**Figure 1: The Remora attached to a submarine**

It is important to note that the converted diving bell was used because of time constraints, but that future developments included much larger cylindrical pressure hulls. This design was not perfect but it did bring fresh perspective to the field of submarine rescue during the 1990's, and it brought fresh inspiration to our ROV design as well.

We decided to adopt some of the Remora design features, including having our floatation and frame built around a central pressure hull. We wanted our pressure hull to be capable of the realistic demands involved in submarine rescue. This included a constant pressure of one atmosphere, a dry atmosphere, and a large enough space for several occupants (scaled down). We decided to place our electronics inside the pressure hull since the need for dry physical space is shared by both human occupants and electronics, and we were not expected to actually take anything into our pressure hull, as described by the competition guidelines.

## **Design Considerations:**

### ***Overall Design Goals:***

The BCIT ROV was designed to be simple and elegant. To that end, every piece was carefully considered for added functionality. A general strategy was to start with the simplest design possible and only complicate it as required. A consequence of this was that a number of components were eliminated or integrated into other components. The systems that were considered and eliminated are as follows:

- Separate frame
- Dynamic buoyancy system
- Tool switching system

Small size was another goal of the project, as a small design costs less to ship, is more maneuverable, and uses less power.

### ***Frame:***

The frame is a crucial part of large commercial and scientific ROVs. This is because frame strength grows with dimension squared while inertial forces grow with dimension cubed. The consequence of this is that, to keep inertial forces proportional to frame strength, frame thickness must grow with dimension to the power of  $3/2$ , requiring a more prominent frame on larger ROVs. This also works in reverse; as the design shrinks, required frame thickness shrinks faster.

The growth rate differences allowed the elimination of the separate frame typical of most ROV designs; at the size of ROV required for the MATE competition, inertial forces are very small, so a prominent separate frame would be wasteful.

### ***Stability and Buoyancy:***

In the interests of simplicity, the ROV was designed to have fixed neutral buoyancy with the propulsion system taking up any loading changes. The buoyancy would be tuned by the addition or removal of foam.

The horizontal axis rotation of an ROV in water can be mathematically described as a damped harmonic motion system. The equation governing damped harmonic motion is a well-known second order linear ordinary differential equation. The almost critically damped solution case corresponds to ideal ROV behaviour; it returns from displacement as fast as possible without significant overshoot. This solution case places some restrictions on the coefficients of the equation.

Owing to the difficulty of parameterizing the equation coefficients in terms of the ROV dimensions, the equation cannot be used to directly produce dimensions. However, understanding the equation can give meaning to the ROV's behaviour and provide a guideline of what to tweak to change it. For instance the equation says that widening the ROV does nothing for static stability and is detrimental to dynamic stability, which is somewhat counterintuitive.

## Design Overview:

### *Subsystems Outline:*

The BCIT ROV system design was simplified and integrated as much as possible without creating troublesome dependency issues. The subsystems that are included in the ROV are as follows:

- Propulsion system
- Pressure hull
- Tool module
- Camera system
- Tether
- Ground station

A schematic view of the placement of components is shown in figure 2 below:

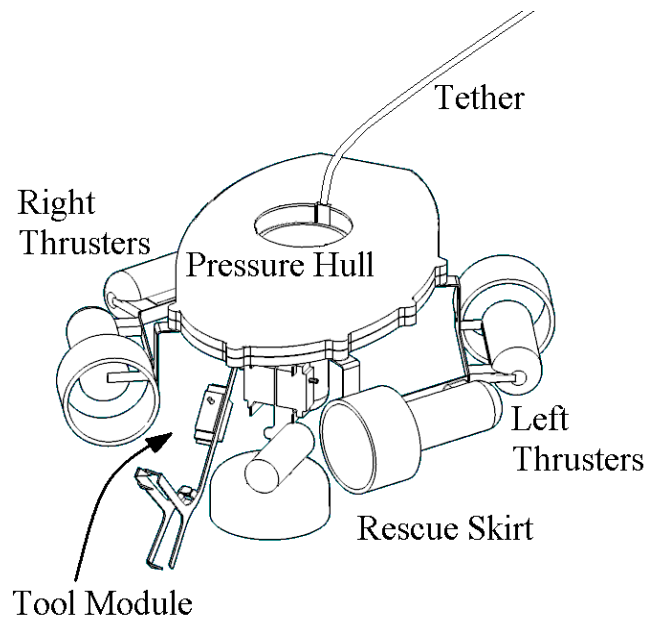
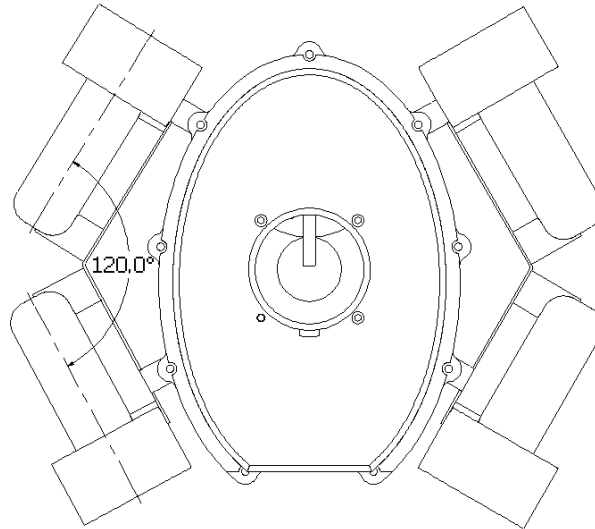

**Figure 2: The ROV layout**

Note that the pressure hull acts as the central component of the entire ROV.

***Propulsion System:***

The propulsion system consists of five 20 V Seabotix BTD 150 thrusters. Each thruster draws 4.25 A at 19 V to produce 20 N of thrust. Four are mounted around the perimeter of the ROV to provide three degrees of freedom in the horizontal plane. The remaining thruster is mounted vertically in the middle to provide movement on the vertical axis. The layout of the thrusters is shown in figure 3 below:



**Figure 3: Thruster layout**

Note the angles of the thrusters. These angles were chosen to give a bias towards forward and reverse speed, at the cost of left and right speed. Maximum forward thrust is approximately 70N. Maximum sideways thrust is approximately 40N. Maximum current draw is 21.25 A.

Strictly speaking, only three thrusters are actually required for 3 degrees of freedom, but the asymmetry of a three thruster design makes the balancing and control math more difficult and error prone.

The four perimeter thrusters are fixed to two subframes, the left subframe and right subframe. The subframes are attached to the bulkhead plate at two points each.

### ***Pressure Hull:***

The main pressure hull serves three separate purposes:

- To provide flotation
- To hold the electronics
- To act as the central “frame” of the ROV

The design has to implement these functions efficiently and elegantly.

Because it acts as the flotation, the volume of the pressure hull has to be independent of other systems and it has to be roughly centred and at the top of the ROV. A duct for the single vertical thruster runs through the centre of the pressure hull.

To keep volume independent of other systems, all physical and electrical connections to the pressure hull are made through a main bulkhead. The bulkhead is a 9.53mm PVC plate. The rest of the pressure hull is separable from this bulkhead for access to the electronics inside. All electrical connections are made through Subconn waterproof connectors. Having all the connections made through the bulkhead leaves the rest of the pressure hull free to change size and shape to suit flotation or space needs.

The seams between the bulkhead and pressure hull are sealed by custom length o-rings. The o-rings sit in CNC machined grooves in the bulkhead that run around the perimeter and thruster duct. PVC plate is used on the pressure hull side to provide a flat surface for the o-ring. The pressure hull itself is made of layers of hard closed cell foam epoxied together and hollowed out. The pressure hull and bulkhead are clamped together with nine bolts around the perimeter and four through bolts around the thruster duct. The assembled pressure hull is shown in figure 4 below:



**Figure 4: The pressure hull bulkhead side**

The bulkhead side (bottom) of the pressure hull is shown. Note the positions of the bolts and connector stubs.

With the thruster duct going up the centre, layout of the electronics inside the hull had to be creative. An ellipse with the back truncated was found to be the best compromise between electronics space, drag, and ROV layout considerations; two printed circuit boards go one at either end of the of the floatation, with the connectors along either side. The internal layout is shown in figure 5 below:

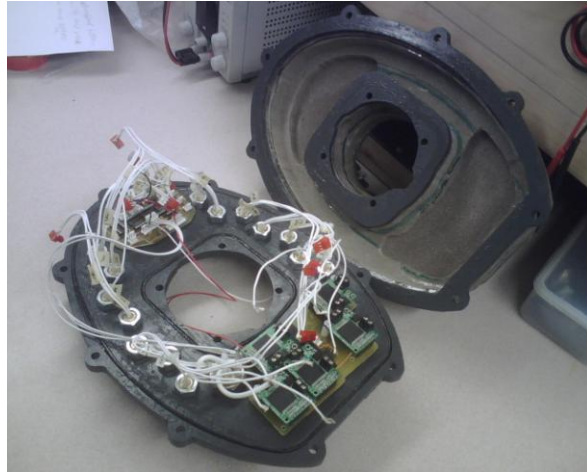
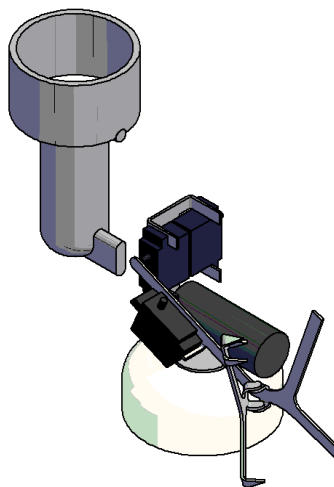

**Figure 5: Pressure hull inside layout**

The bulkhead plate and circuits are shown with the top cover removed. Note the two o-rings around the outside edge and inside edge.

***Tool Module:***

A criterion of the tool subsystem was that it should not be affected by changes to the design of the ROV. To that end, the tool system was encapsulated into a simple module designed to attach to the bottom centre of the ROV, which ended up being the vertical thruster. The tool system attaches to the vertical thruster as shown in figure 6 below:



**Figure 6: The tool module attaches to the vertical thruster**

All the tool subcomponents mount to the central bracket component.

The tools themselves were designed to be

- Simple
- Low impact (drag and weight)
- Multipurpose
- Quick to prototype and change
- Able to do all the tasks as fast as possible

To make prototyping and modification as fast as possible, all the custom tool parts are made of galvanized steel sheet, standard bolts, and coat hanger rod. Sheet metal is used because it is easy to cut out shapes and work with them, which speeds up prototyping.

The tools consist of two mirrored arms, each of which uses two servos for actuation. Each arm pivots at the shoulder and has two sets of fingers that can open and close. One of the arms is shown in figure 7 below:

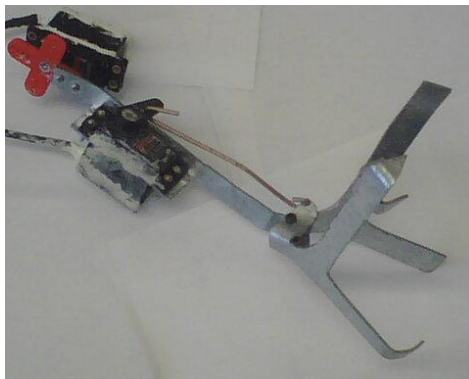

**Figure 7: A tool arm with servos and linkage**

The arms pivot directly at the shoulder servos, and the fingers are actuated through a linkage to the finger servo, which is mounted part way up the arm. Each arm can carry two ELSS pods comfortably for a total load capacity of four pods. To open the hatch wheel, the two rear fingers are inserted into the slots and the entire ROV is rotated. For the air line and hatch rescue tasks, the arms are swung up to the forward position to manipulate the door, lever and air line, and to get out of the way for landing.

The finger and shoulder servos are attached to the arm and bracket by the same tab system. Two tabs are placed a servo length apart, and small bolts are used to fix the servo to the tabs.

The tool system uses servos because they are cheap, available and have a simple pulse width modulation control interface. To waterproof the servos, an o-ring is placed around the output shaft and the cracks are sealed with marine sealant. The tooling uses four Hitec HS-645MG servos.

The rescue skirt is mounted on the bottom of the tool module. The overall placement on the ROV is slightly forward of the bottom center. The rescue skirt is a cheap plastic lunch container. This is used because it is of exactly the right dimensions, and it is very light.

### ***Camera System:***

The connector bulkhead and transmission system of the ROV supports up to four composite signal cameras. The cameras are Lights Camera Action waterproof infrared cameras.

One camera is mounted right on top of the rescue skirt for a forward view. Two more cameras are mounted above behind and to either side of the tool module, to oversee tool operation. Two cameras are used for tool views to give some amount of depth perception to the operators. Another camera may be placed if it is needed.

### ***Tether:***

The tether consists of three parts:

- Category 5e patch cable
- Power wire
- Macrosphere floatation

The macrospheres are contained in an expandable cable sleeve, and the whole assembly is zap-strapped together. The macrospheres keep the tether neutrally buoyant, but it also has larger floats placed at strategic locations to keep it under control.

The power wire carries 24 V and up to 25 A. The Cat 5e cable has four twisted pairs of wires. Two pairs are used to transmit two video signals. The other two pairs are used for EIA 485 serial communication between the ROV and the surface.

At the ROV side, the tether plugs into the bulkhead and is routed up through the thruster duct to leave the ROV at the top centre. The tether was designed to come out of the axis of rotation so that it doesn't hinder maneuverability. A groove in the top of the pressure hull encourages the tether to lie down flat such that it effectively comes out of the back of the ROV during forward movement. This design was inspired by what is done on some professional ROVs.

### ***Surface Station:***

The surface system consists of the electronics that communicate with the ROV, input systems, a power supply, and screens to display what the ROV can see.

The input system was originally a knock-off Playstation 2 controller, but due to problems with that system, the controls are being ported to a single joystick with some extra potentiometers.

The only feedback from the ROV is the video signals from the cameras, which are displayed on two television screens. Each screen can switch between two cameras. The switching is done electronically on the ROV and only two camera signals are sent up the tether.

The ROV is a 24 V system so a TRC Electronics 24 V DC power supply is used to step down the voltage from 48V.

***Assembly Details:***

The ROV assembly is put together from the following subassemblies:

- Pressure hull
- Thrusters
- Tools and cameras
- Tether

These assemblies go together all at once and it is difficult to remove just one subassembly without disassembling the entire ROV. Fortunately, the ROV is simple and small so this is not too much of a problem.

The tool module with the forward camera screws into the mounting holes on the vertical thruster to form the bottom assembly

The vertical thruster is pressed into the thruster duct in the hull along with the tether. The thruster is kept from turning by a protrusion on the thruster acting as a key. It is kept from going through the top by a step to smaller diameter in the duct. It is kept from falling out the bottom by washers on the through bolts that hang over the edge of the hole. This secures the bottom assembly to the top and the tether.

The horizontal thrusters are screwed onto the left and right mounting brackets, which are attached to the left and right side of the ROV by the wing nuts that hold the box closed. The entire assembly is shown in figure 8 below:

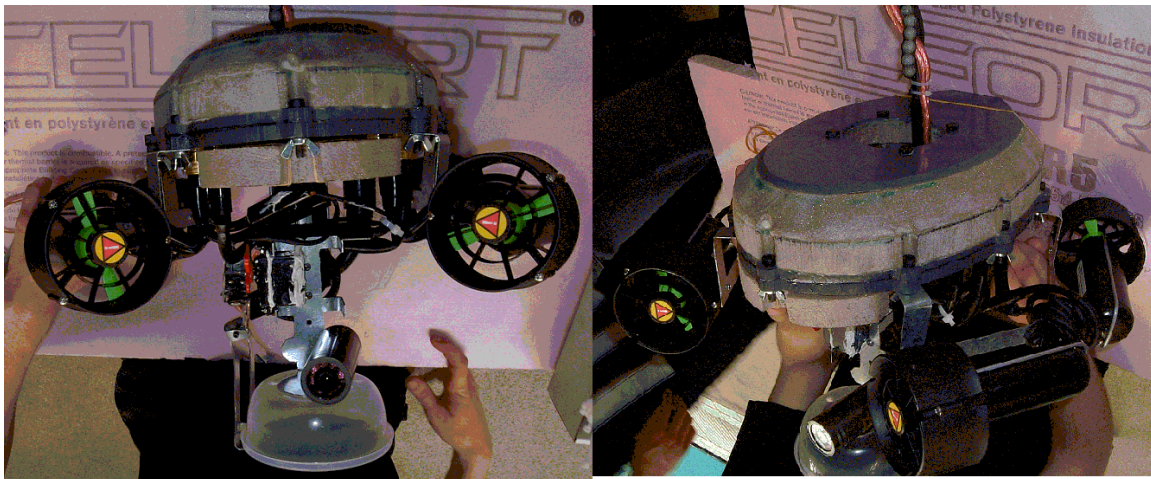

**Figure 8: The finished ROV**

Once everything is in place, the connector wires are wrapped up and organized so they don't interfere with camera views or tool operation.

## Control system Details:

### *System layout:*

The control system electronics are distributed between three separate modules:

- User interface module
- Tool control module
- Thruster control module

Each module contains an Atmel ATmega644 AVR microcontroller on a custom printed circuit board. The GNU Compiler Collection supports the AVR architecture so programming can be done in high level languages like C. Being able to program the ROV in a high level language allows faster design changes and easier debugging.

### *User Interface Module:*

The user interface module is located in the controls on the surface. It receives input from the input devices, transforms it into instructions for the ROV, and sends the instructions down the tether via EIA485. Its operation is outlined in figure 9 below:

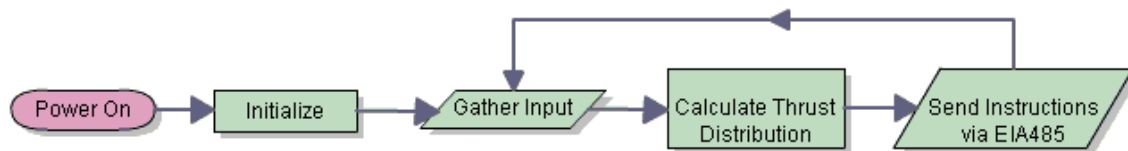

**Figure 9: User interface module flow chart**

Transforming the input values to horizontal motor instructions involves a number of sub-steps. The steps for converting from input to output instructions is as follows:

- The input values are biased so that they go from -128 to 127 instead of 0 to 255
- The input is interpreted as desired amounts of forward/reverse, left/right and clockwise/counter clockwise
- The forward/reverse and left/right is interpreted as a desired direction vector
- For each motor, the dot product is taken between the direction vector and the thruster direction unit vector
- The rotation amount is either added or subtracted to the dot product, depending on the direction of the thruster. This gives the desired thruster output.
- Thruster output is capped to avoid overflow
- Thruster output is encoded into the transmission format

The vertical thruster input is simply biased and encoded into transmission format. The servo control inputs are sent down directly. Once all the inputs have been processed, they are packed into a ten byte message and sent down the tether.

The input devices include:

- A three-axis joystick for horizontal control
- A dial for vertical control
- Switches for speed control
- Four dials and a switch for tool control
- Switches for camera control

The joystick and dials use potentiometers for output.

A list of parts and schematic diagram of the user interface board is included in appendix A.

### ***Tool Control Module:***

The tool control module is located in the front of the ROV. It receives the instructions from the surface through the tether, sends instructions for four of the thrusters to the thruster control module via SPI (Serial Peripheral Interface), and controls the cameras, servos, and one thruster according to the remaining instructions. A diagram of its operation is shown in figure 10 below:

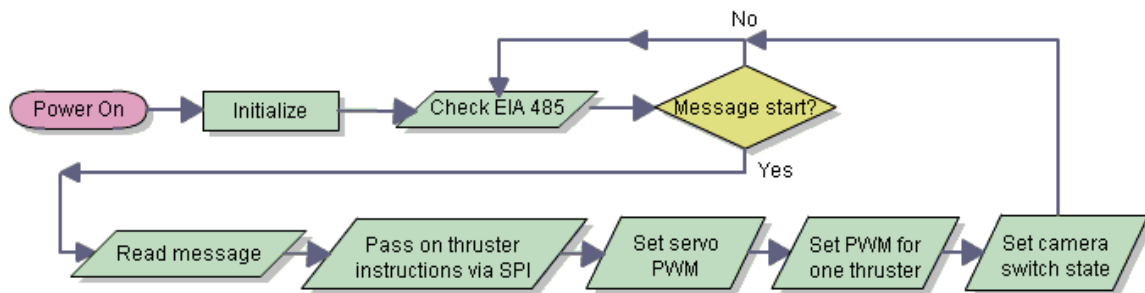

**Figure 10: Tool control module flow chart**

The tool control module controls one of the thrusters because the SPI slave select takes up a pulse width modulation pin on the thruster control processor. This configuration is non-ideal, but changing it would create a hardware imbalance because of the other duties that the tool control board fills.

A list of parts and schematic diagram of the tool control board is included in appendix A.

### ***Thruster Control Module:***

The thruster control module is located in the back of the ROV. It receives instructions from the tool control module via SPI, and outputs PWM signals to the motor controllers according to the instructions. Its operation is outlined in figure 11 below:

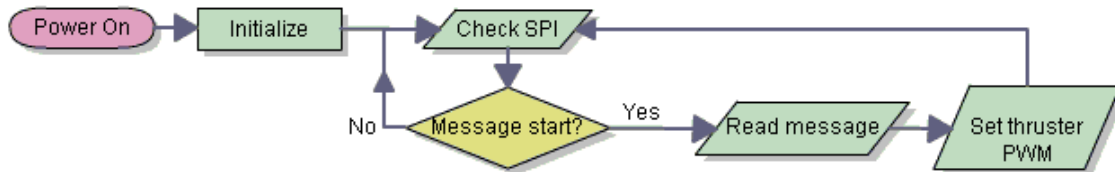

**Figure 11: Thruster control module flow chart**

The thruster control board doesn't have a lot to do because the thruster control hardware takes up a lot of space; the motor control board has five Pololu DC motor drivers attached to it.

A list of parts and schematic diagram of the thruster control board is included in appendix A.

### **Challenges and Troubleshooting:**

#### ***Control Meltdown:***

Right before the qualifications on May 9<sup>th</sup>, the controls stopped working. Only three thrusters were running and they weren't responding correctly to input. Also, the potentiometers in the controller had bad connections in them so the input signal was very unreliable.

Using the oscilloscope, we figured out that the motors weren't running because the pulse width modulation was too fast so the motor controllers had overheated and shut down. When we went to reprogram the PWM and get the motors responding correctly, we discovered that the programming board wasn't working either.

We went out to try to get more reliable potentiometers and a new programming board, but we couldn't find an electronics store, so we got lamp cord and DPDT switches. We managed to get the whole thing soldered together and running in time to qualify for the competition. It was a challenge to drive but it worked.

We used an oscilloscope extensively for debugging and troubleshooting of the controls.

From that experience we learned how well we can work together as a team. We also learned that we should get the ROV running before worrying about anything else, because if the ROV doesn't run, nothing else makes a difference.

### ***Floatation:***

Throughout the design process, we made the assumption that because the controls had to fit inside the floatation, it would be oversized and we would have to add weight to the ROV. This assumption made us spend a lot of time making the electronics as compact as possible. When it came time to put the ROV in the water, we discovered that it sank quite quickly. We had to add a lot of foam to get it to float, and the added foam ruined a lot of the elegance of the design.

The mistake we made was to make too many unfounded assumptions and to leave it too late to get actual data. If we had done a lot of testing to get the feel for how much floatation a given component needs, we could have avoided the problem.

To solve the problem we will be rebuilding the pressure hull to displace more water.

### ***Tool Design Iterations:***

As soon as we had a tool design that we felt could do the tasks, we started prototyping and testing, first in cardboard, then aluminum. The prototypes allowed us to test the geometry and discover problems. The following design changes resulted from prototyping and testing the tools:

- Galvanized steel instead of aluminum
- Extra claws to grip air line
- Extra fingers for more ELSS pods and hatch wheel
- Bends in the tools to clear the skirt

If we had not chosen to do prototypes with a design that is quick to build and change, we wouldn't have been able to improve the tools to the level that they are at.

The success of the tool design and the failure of the floatation together taught us the value of prototyping and testing.

## **Scheduled and Hypothetical Changes:**

### ***Tether Optimization:***

The tether is oversized and too stiff. The 12 gauge speaker wire and heavy duty category 5e patch cord together make it quite bulky and heavy. The density of floatation required to keep it neutrally buoyant make the stiffness and drag problems even worse.

In the optimized tether, 16-gauge wire will be used instead of 12-gauge. A lighter duty patch cord will also be used to reduce stiffness.

### ***Floatation Rebuild:***

The floatation is insufficient as is without adding large amounts of foam in awkward places.

The top cover of the electronics will be rebuilt to occupy a lot more space. Additional foam may be used in a few places to tune the floatation, but it will be kept to a minimum.

**Lighter cameras:**

Part of the problem with the floatation is that the cameras are extremely heavy. They are machined from solid brass and weigh 450g each.

If possible, lighter cameras will be found and used.

**Better Electronics:**

If there was a lot more time, or if the project were continued next year, the electronics could be made much smaller by using surface mount integrated circuits instead of dual inline package. Surface mount would allow the use of only one microcontroller on the bottom, because it could have enough pins to control everything. Everything would fit onto one small board, which could give a lot more freedom in the design of the pressure hull.

These improvements will not be made before the competition.

**Project Budget and Expenditures**

The project did not have explicit budget constraints. BCIT had to approve large purchases, but that was the only limitation. The parts that were bought and how much they cost is outlined in table 1 below:

**Table 1: Money Spent**

<b>Description</b>	<b>Details / Part Numbers</b>	<b>Qty</b>	<b>Unit Price</b>	<b>Spent</b>
Camera Switch	Digikey # ADG509AKNZ-ND	2	\$6.82	\$13.64
EIA485	Digikey # MAX487CPA+-ND	3	\$3.79	\$11.37
Microcontroller LM5575 Evaluation Board	Digikey # ATMEGA644-20PU-ND LM5575EVAL	5 1	\$10.61 \$53.79	\$53.05 \$53.79
DC-DC convertor 48V-24V	SD-1000L-24	1	\$376.92	\$376.92
Tether	12 gauge speaker wire	18.5 m	\$3.90	\$72.15
Thruster	Seabotix BTD 150	5	\$500.00	\$2,500.00
Wire	18 gauge electrical wire	3	\$21.00	\$63.00
PS2 controller	For controlling the ROV	1	\$8.00	\$8.00
PVC Plate	From smallparts.com	4	\$15.00	\$60.00
Servos	Hitec HS-645MG	6	\$50.00	\$300.00
Other components	Assorted other components			\$100.00
			Total bought	\$3,611.92

All prices are in Canadian dollars. A number of components were also donated to the project they are shown in table 2 below:

**Table 2: Donated parts**

<b>Donor</b>	<b>Description</b>	<b>Details</b>
BCIT	Waterproof Cameras	Lights Camera Action LCA 7700-C
Private Donation	Closed cell hard Foam	For the pressure hull
Subconn	Waterproof Connectors	Subconn micro series connectors
Subconn	Tether	Category 5 patch cable
BCIT	Galvanized steel sheet	Used for tools and thruster brackets
BCIT	Plastic boxes	For ground station

A \$100 dollar private donation was also received.

**Reflections:**

Building the BCIT ROV has been a very valuable learning experience. We learned a lot about the design process, what works and doesn't, and we have all become better team members. The skills and experience gained during the course of this project have nicely complemented our formal education.

We also learned a lot about the marine industry and the engineering industry in general as we have had to do a lot of communicating with professionals and organizations. This experience will help us greatly as we begin our careers in engineering.

## **Research Sources:**

Frank Owen, LCDR David Jones RAN,. "REMOTELY OPERATED RESCUE VEHICLES – ARE THEY REALLY THE SOLUTION?" 05 2002. 03 2009 <<http://www.idpm.biz/downloads/RINA%20RORV%20v%20SRV.pdf>>.

Research-Submarine Rescue System. 03 2009 <<http://www.nuytco.com/research/rescue.shtml>>.

US Navy introduces “State of the ART” remotely operated submarine rescue vehicle to the world. 10 10 2008. 03 2009 <<http://www.shephard.co.uk/news/331//>>.

## **Appendix A: Parts lists and schematics**

### ***User Interface Module Parts:***

The major components of the user interface module are as follows:

- 1x Atmel AVR ATmega 644-20PU microcontroller.
- 1x MAX 488CPA+ serial communication chip.

### ***Tool Control Module Parts:***

The major components of the tool control module are as follows:

- 1x Atmel AVR ATmega 644-20PU microcontroller.
- 1x MAX 488CPA+ serial communication chip.
- 1x LM5575 power supply board, 5V.
- 1x ADG509AKNZ analog multiplexer.
- 1x LM7812CT Linear regulator, 12V.

### ***Thruster Control Module Parts:***

The major components of the thruster control module are as follows:

- 1x Atmel AVR ATmega 644-20PU microcontroller.
- 5x Pololu MD02B motor drivers.

User interface Schematic:

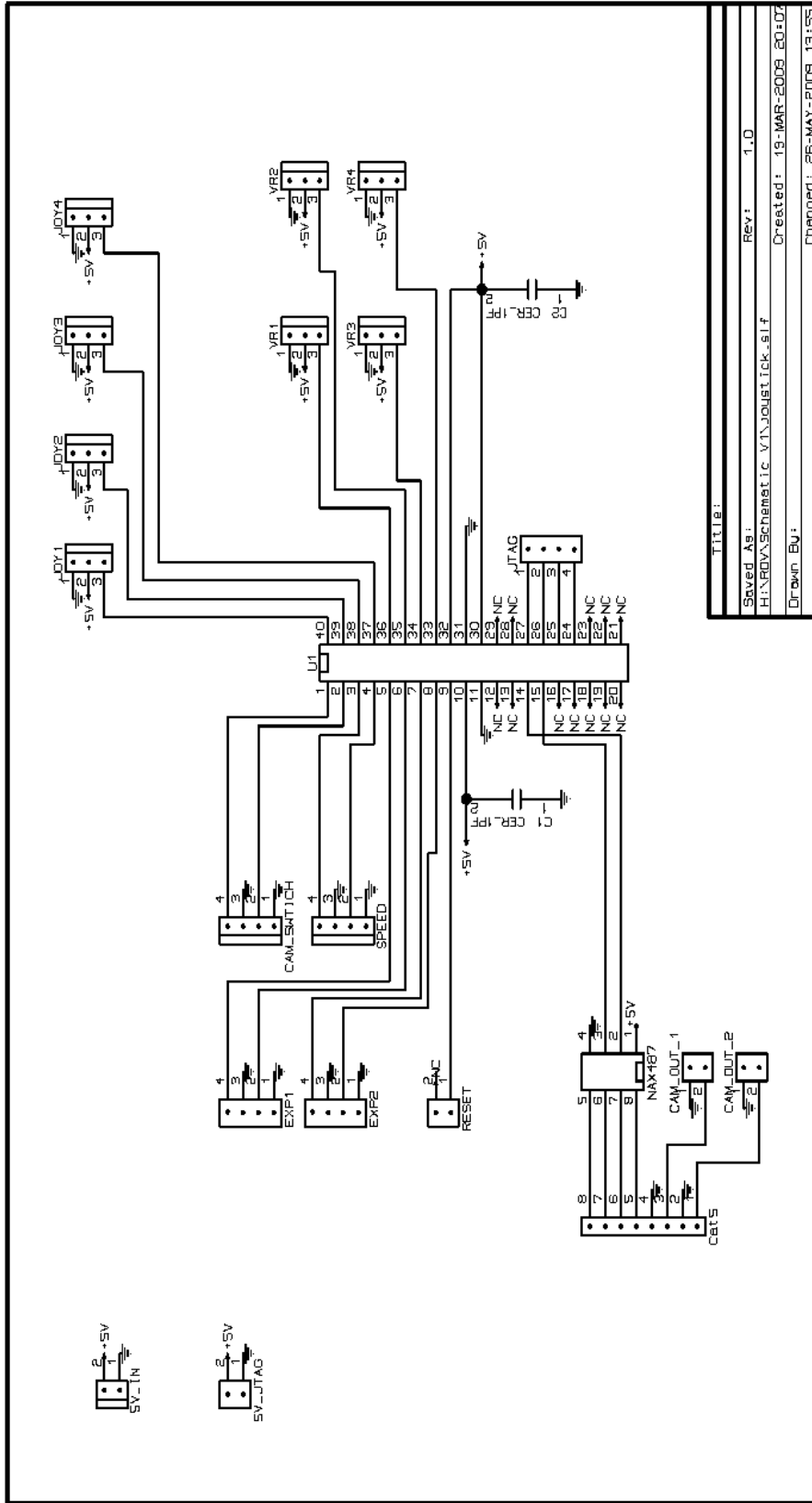

Title:	
Saved As:	Rev: 1.0
H:\PROJAS\Schemat.Ic.V1\Jouist.Ick.s1.f	
Drawn By:	Created: 19-MAR-2009 20:07
Changed: 26-MAY-2009 13:55	

# Tool Control Schematic:

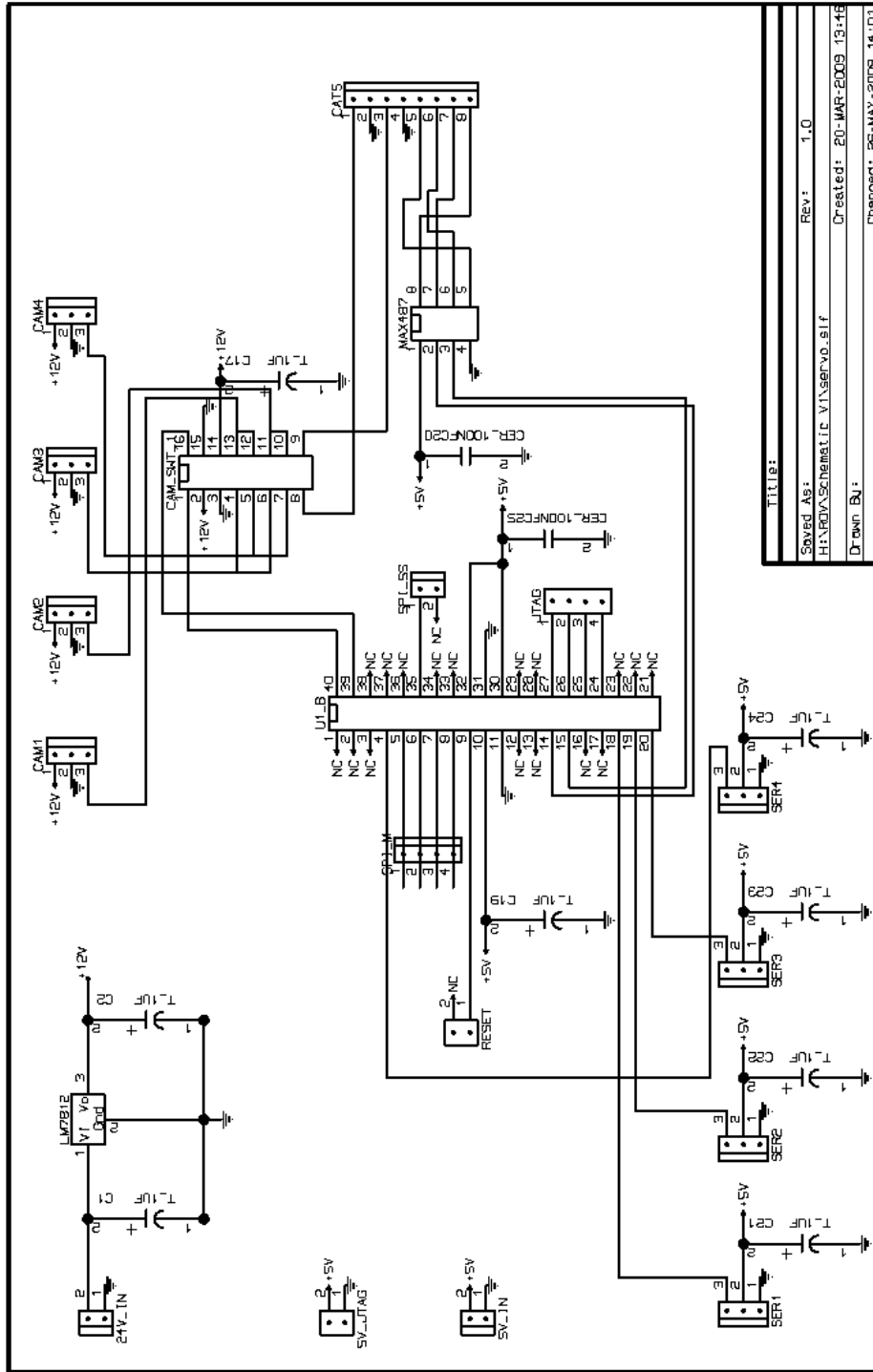

TITLE:	
SAVED AS:	REV: 1.0
FILE:	HI-POV\SCHEMATIC\VISERVO.SIF
CREATED:	20-MAR-2009 13:16
DRAWN BY:	CHANGED: 26-MAY-2009 14:01

# Motor Control Schematic:

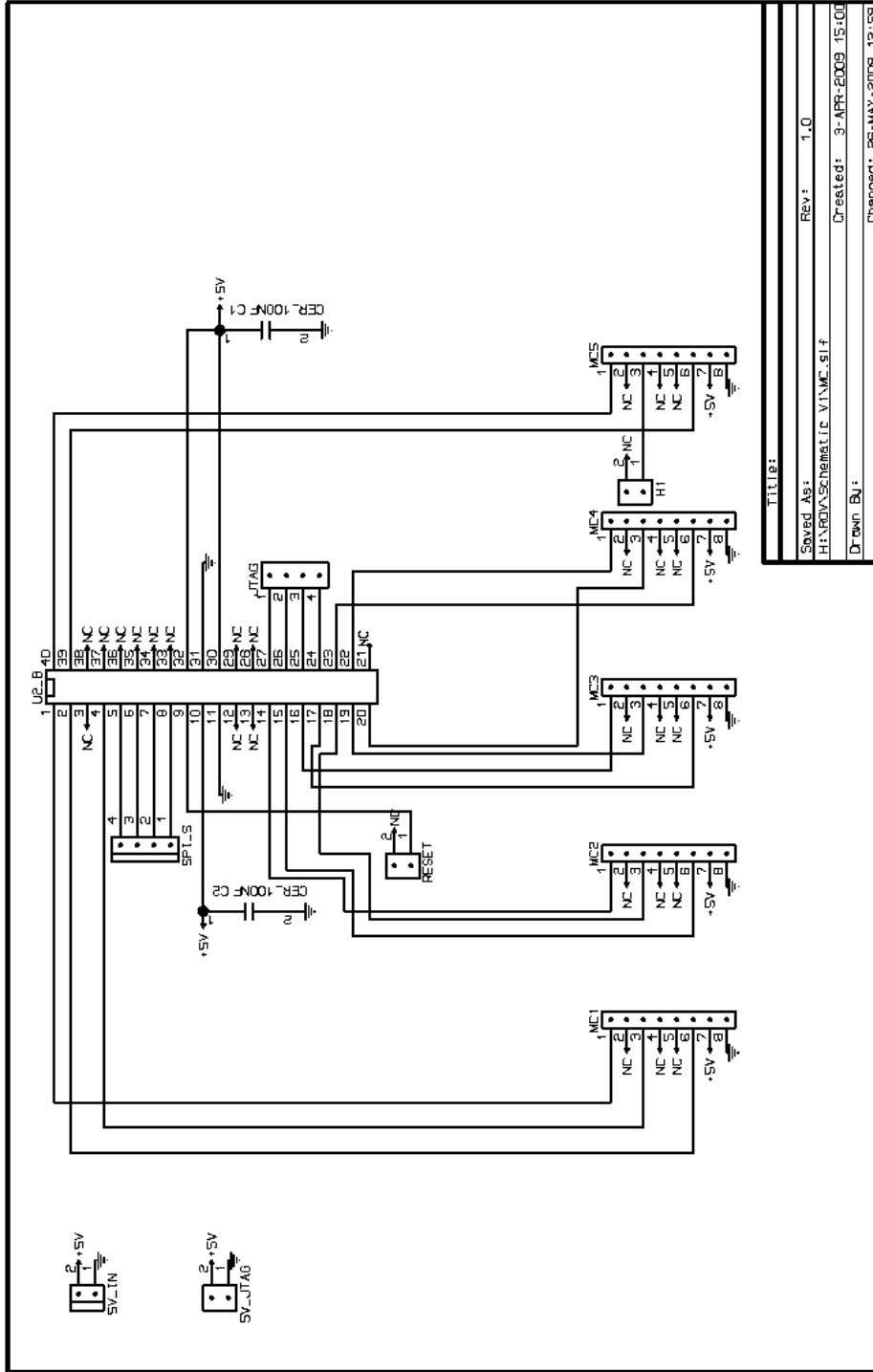

TITLE:		
Saved As:	REV:	1.0
H:\PDA\SCHEMATIC\1\1\M.C.51.f		
Created: 3-APR-2009 15:00		
Drawn: BU		
Changed: 28-MAY-2009 13:53		