

The Dalhousie Privateers

Dalhousie Engineering

2009 MATE International ROV Competition

Explorer Class

The Black Pearl

The Team

Ian Bailey, Sebastien Bourdage, Chris Brake, Stuart Conrad, Joe Duschense, Matthew Gale, Robert Jefferson, Piotr Kawalec, Michael Marchand, Ellen McCardle, Kaylyn Monk, Dainis Nams, Trevor Pace, Peter Pearl, Timothy Pohajdak, Danilo Prieto, Alexandra Smith, Kathleen Svendsen, Daniel Verner

Mentors

Dr. J Gu, Dr. G. Jarjoura, Dr. C. Watts

Contents

Contents	i
Acknowledgments	ii
Abstract	iii
The Crew	iv
Project Budget	v
The Construction of the Black Pearl.....	1
The Frame	1
Propulsion Systems.....	1
Electronics Housing	2
Tether	2
Power Box	4
Camera Mounts.....	5
Onboard Electronics	6
Micro-Controller Board.....	6
Octal Unidirectional Motor Control.....	6
Multidirectional Motor	7
Software.....	8
Video Interface.....	10
Tools	10
Multi-Purpose Brush.....	10
Pod Transfer Hooks	10
Airline Insert Alignment System.....	11
Escape Hatch Cover	11
Challenges Faced.....	11
Troubleshooting Techniques	12
Lessons Learned and Skills Gained.....	12
Reflections	13
NSRS NATO Submarine Rescue System.....	13
Appendix A – Exploded view of core mechanical components	A

Acknowledgments

We would like to sincerely thank our generous sponsors:

- Shell Canada
- The Binnacle
- Rods Machine Shop
- Department of Engineering of Dalhousie University
- Kinacor Inc

We would also like to thank our mentors for all the help they have given us. Dr. George Jarjoura, Dr. Chris Watts and Dr. Jason Gu.

A special thanks to:

Dr. Joshua Leon, Dr. Larry Hughes, Chris Hill, Mark LeBlanc, Ian McKenzie, Angus MacPherson, Albert Murphy, Reg Peters, Linda Conrad, Barbara Labecki, Dennis Myers, Jim Parsons, Ian Dempsey, and Glenn Macleod.

We would also like to thank all of our families, friends and people who helped and supported us upon our endeavour.

Abstract

The Dalhousie Privateers' report details this year's entry into the 2009 MATE ROV competition. The report details the design rationale behind both the mechanical and electrical systems implemented in our ROV: the *Black Pearl*. Whenever possible, our vehicle's components were designed, manufactured, programmed, and assembled by team members. This year much of our raw material was donated from various sponsors, enabling us to keep the construction cost of our vehicle to a minimum.

Housed in our aluminium frame are the five motivational motors required to move our vehicle about the pool. The lift motor, a full size MinnKota trolling motor, was salvaged from last year's design and provides our vehicle with 36lb of lifting force. Arranged in a vector drive format are four Rule 1100 bilge pumps, providing the *Black Pearl* with extremely fine lateral control.

To improve upon a past weakness our on board electronics are housed in a solid aluminium box capped with a half inch acrylic lid to prevent water damage. In addition to the enhanced electronics housing we have spent considerable time creating our own power distribution system in order to test our robot.

Once again, all of our software has been created in house, but last year's on-board computer has been replaced by a PIC micro-controller. Control of our ROV is accomplished through a X-box 360 controller that is connected to a standard laptop.

In short, we are proud to return to the MATE international ROV competition to present the second Dalhousie Privateers' vehicle:

The Black Pearl

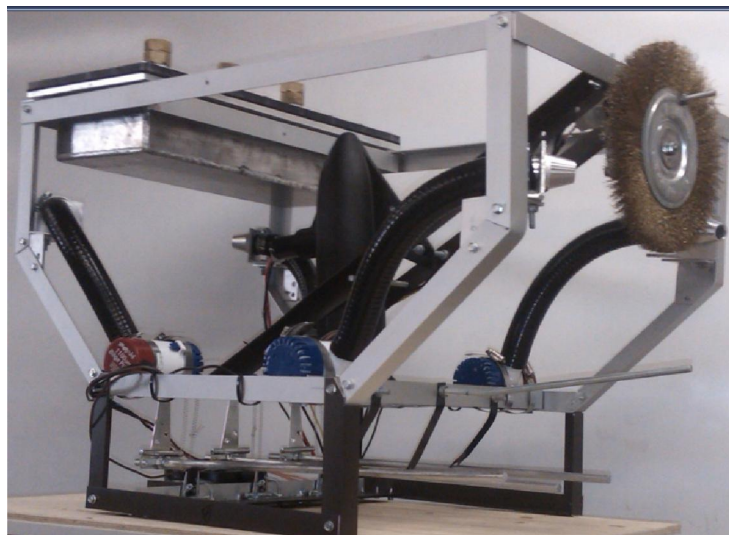

The Crew

Despite the hardships faced by the crew last year many chose to remain, and in addition to these stalwarts we have bolstered our ranks with new recruits from the first two years of Dalhousie's Engineering program.

Rescue not being a normal activity for a privateer some would question whether we could bring ourselves to design for such a task, but alas... there is little that we will not do in pursuit of gold and silver.

Ships Officers

Captain Peter Pearl (Electrical Leader) - 3rd Year Electrical
First Mate Dainis Nams (Mechanical Leader) - 3rd Year Mechanical

Deck Hands

Ian Bailey- 2nd Year Mechanical
Sebastien Bourdage- 2nd Year Electrical
Chris Brake- 2nd Year Mechanical
Stuart Conrad- 2nd Year Mechanical
Joe Duchense- 3rd Year Computer Engineering
Matthew Gale- 3rd Year Computer Sciences
Robert Jefferson- 1st Year Mechanical
Piotr Kawalec- 2nd Year Mechanical
Michael Marchand- 3rd Year Mechanical
Ellen McCardle- 3rd Year Environmental
Kaylyn Monk- 2nd Year Environmental
Trevor Pace- 2nd Year Electrical
Timothy Pohajdak- 3rd Year Mechanical
Danilo Prieto- 2nd Year Mechanical
Alexandra Smith- 2nd Year Mechanical
Kathleen Svendsen- 1st Year Computer
Daniel Verner- 3rd Year Mechanical

Project Budget

Part	Quantity	Cost Per Unit (CA)	Total (CA)	Source	Donated/ Purchased
Resistors Various Values	60	0.01	0.6	Dalhousie Electrical Department	Donated
Heavy Duty Ring Connectors	40	0.11	4.4	Princess Auto	Purchased
Screw Down Terminal (2post)	20	0.55	11	Digikey	Purchased
Project Development Boards	3	30	90	Dalhousie Electrical Department	Donated
IRF540 Hexfet N-Channel	8	1.75	14	Dalhousie Electrical Department	Donated
10TQ040PBF Power Diode	10	3.2	32	Dalhousie Electrical Department	Donated
LM7805 Fixed Voltage Reg	4	0.59	2.36	Dalhousie Electrical Department	Donated
74LS00 QUAD NAND Dual input	4	0.74	2.96	Dalhousie Electrical Department	Donated
2N3904 NPN BJT Transistor	8	0.14	1.12	Dalhousie Electrical Department	Donated
4N25 Optical Coupler	1	0.74	0.74	Dalhousie Electrical Department	Donated
Red LED	20	0.87	17.4	Dalhousie Electrical Department	Donated
Green LED	3	0.87	2.61	Dalhousie Electrical Department	Donated
EMUFD 48-12 Power converter	1	519.98	519.98	Digikey	Purchased
Polulu Dual H-bridge	1	70.53	70.53	Robotshop.ca	Purchased
100u Electrolytic Caps	3	1.53	4.59	Dalhousie Electrical Department	Donated
PIC16f877 Micro Controller	1	4	4	Microchip.com	Purchased
TIP 31C NPN Power Transistor	1	0.5	0.5	Digikey	Purchased
TL084 Rail to Rail Op Amps	2	2.29	4.58	Dalhousie Electrical Department	Donated
16V Zener Diode	1	1.57	1.57	Dalhousie Electrical Department	Donated
SPDT switch	3	2.99	8.97	Princess Auto	Purchased
Marine Master Battery Switch	1	5.99	5.99	Princess Auto	Purchased
40A resettable breaker	1	2.99	2.99	Princess Auto	Purchased
Emergency Cut off Switch	1	5.99	5.99	Princess Auto	Purchased
60A Analog Current Meter	1	29.99	29.99	Princess Auto	Purchased
20V Analog Volt Meter	1	29.99	29.99	Princess Auto	Purchased
Power Bar	1	9.99	9.99	Real Atlantic Superstore	Purchased
Tyco Power Relay DPDT w Stand	10	25	250	Digikey	Purchased
120AC to 12 VDC Power Adaptor	1	29.99	29.99	Princess Auto	Purchased
48VDC to 12V DC Converter	1	110.95	110.95	Digikey	Purchased
Power Distribution Box	1	9.99	9.99	Princess Auto	Purchased
12 Volt 6 Cell Battery	4	79.98	319.92	Dalhousie Electrical Department	Donated
12 Volt 2A Charger	1	59.99	59.99	Princess Auto	Purchased
RCA Jacks	5	2.99	14.95	Dollar Store	Purchased
15m Power Extension Cord	1	49.99	49.99	Princess Auto	Purchased
17 Inch LCD Monitor	1	220	220	Dalhousie Core Years Director	Donated
Electrical Bus Strips	5	5.99	29.95	Princess Auto	Purchased
DB9 Connector	1	3.99	3.99	Dalhousie Electrical Department	Donated
USB to RS232 Converter	1	19.99	19.99	Greenlyph Computers	Purchased
Phenolic Project Boards	2	5.99	11.98	The Source	Purchased
Rule 1100 Bilge Pumps	4	45	180	The Binnacle	Purchased
Minn Kota Enduring Trolling Motor	1	149.99	149.99	Canadian Tire	Purchased
Surplus Electrical motor with Gear Box	1	10	10	Princess Auto	Purchased
Surplus Power door lock mechanisms	4	9.99	39.96	Princess Auto	Purchased
Machined Nozzles	4	50	200	Rod's Machine Shop	Donated
Camera Mounts Fast Proto-typed	5	12	60	Dalhousie Mechanical Department	Donated
Fish TV	5	89.99	449.95	Cabela Canada	Purchased
Brush Wired	1	14.99	14.99	Canadian Tire	Purchased
Plate Aluminum	1	100	100	Metals are Us	Donated
Aluminum 1 1/2 Angle (Meters)	20	20	400	Metals are Us	Donated
Aqua Seal Tank Sealant	14.99	3	44.97	Pets Unlimited	Purchased
1 1/2 Rubber hosing	3	0.75	2.25	The Binnacle	Purchased
Gasket Material (square meters)	0.5	4	2	Nova Automotive	Purchased
Mechanical Fasteners	1	60	60	Canadian Tire	Purchased
		Sub Total	3848.99		
Proto typing Budget	1		700	Shell Canada	Donated
		Total	\$4548.99		

The Construction of the Black Pearl

The Frame

The frame of the Black Pearl was constructed out of 1 ½" by 1/8" angle aluminium. This material was chosen because it is light, easy to work with, and provides easy 90° angle mounting points for attachments. The wide-top frame design with open fore/aft sections was chosen to provide excellent stability due to the fact its center of mass is well below its center of buoyancy. In addition the frame allows ample room for central-front mounted tooling. Refer to *Appendix A – Exploded view of core mechanical components* for a more detailed schematic of the core frame components.

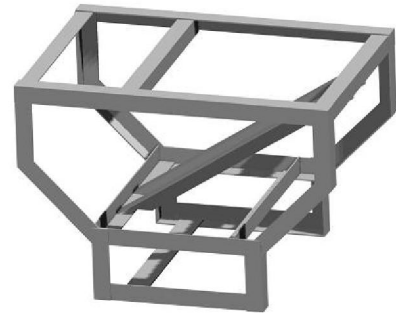

Figure 1: Aluminium Frame

Propulsion Systems

The propulsion system for the Black Pearl consists of two distinct components. A single MinnKota trolling motor provides the vertical thrust for the ROV. Capable of delivering 160N of thrust this motor provides our vehicle with more than enough power to lift all five supply pods simultaneously. Four RULE 1100 bilge pumps in a vector configuration provide front/back and lateral motion to the vehicle. Due to the high degree of manoeuvrability allowed by the vector configuration and the small space requirements of bilge pumps, the vehicle is highly manoeuvrable.

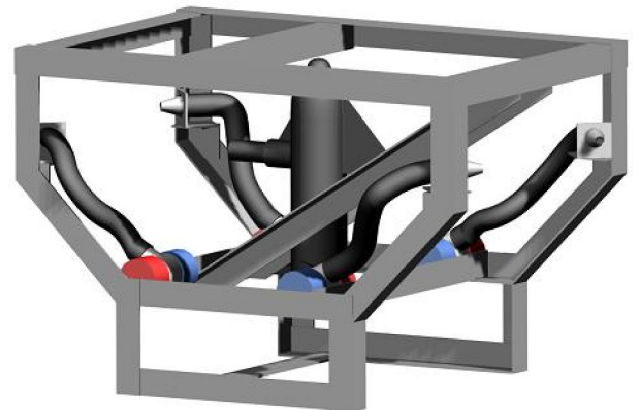

Figure 2: Propulsion System

Since our team decided to use a water jet propulsion system in order to effectively move the ROV underwater, our challenge was to optimize that system to be as cost and power efficient as possible. Because we decided to use commonly available bilge pumps with limited capabilities the only way to increase their thrust output was by using optimally designed nozzles.

Our team decided to implement a venturi type nozzle, commonly used in jet skis and other jet propelled vehicles. This nozzle is based on the effect of a pressure drop in pipe flow when the cross sectional area of the pipe decreases and by doing so it increases the velocity of the fluid flowing downstream. The amount of increase of velocity can be simply calculated using Bernoulli's continuity equation, as detailed below.

$$p_1 - p_2 = \frac{1}{2} (V_2^2 - V_1^2)$$

$$\text{and } A_1 V_1 = A_2 V_2$$

Therefore:

$$A_2 < A_1, V_2 > V_1, \text{ and } p_2 < p_1$$

Decreased area = decreased pressure = increased velocity

Force (Thrust) = mass flow * velocity

The major challenge in designing the nozzles was to optimize the step-down in diameter while still maintaining sufficient flow from the bilge pumps. In order to be able to do that we have contacted the manufacturer of the pumps and obtained the pressure-head charts which gave us information about the expected flow from the pumps for given amount of nozzle backpressure. Having that information allowed us to plot a chart with a series of possible nozzle sizes matched with their corresponding amount of flow, highlighting the one which created maximum amount of thrust.

As a result we have produced a nozzle which theoretically gave us approximately 60% increase in the amount of thrust each pump can generate. We were also able to qualitatively confirm that result during our pool tests when we compared the speed of the craft with the nozzles installed to the speed with unrestricted pumps. Even though the nozzles do increase the pump's thrust, an improvement for future designs would be to add a secondary set of pumps and nozzles, effectively doubling the ROV's lateral thrust capacity.

Electronics Housing

Since a majority of problems last year arose from our on board electronics box flooding, this year team members designed an improved electronics housing. This design was machined and assembled by Dalhousie's Mechanical Engineering Department machine shop. The housing is constructed from 6mm plate aluminium and 13mm Plexiglas. A neoprene gasket was cut to fit the exact dimensions of the box in order to form absolute seal between the Plexiglas lid and aluminium box. In order to ensure the wires used to power the various motors of the ROV could be passed into the box while maintaining its water tight seal, brass pipe fittings have been fitted into the lid. In order to provide removable connections the desired cables have been inserted through a 5cm length of hose and then through another brass fitting. This assembly has been filled with Aquaseal®, a high grade adhesive sealant used to construct aquariums. Constructing the body of the box from aluminium allows us to heat sink the electronics directly to it, and the Plexiglas faceplate allows us to observe the status indicators of the on board electronics without opening the box.

Tether

Our 15m tether consists of a heavy duty extension cord and the tethers for the five Fish TV cameras. Sections of pipe insulation have been used in order to ensure the tether is neutrally buoyant.

The extension cord used is rated to deliver 3.6KW, and the maximum electrical power allowed by competition rules is 1.9KW. The difference between the cables rating and our requirements give a large margin for safety.

In order to allow easy disconnection of the tether from the command centre the female end of the extension cord was severed from the cord itself. This end of the cord was then fed into the power distribution box and its two main conductors connected to the output of the 48V_{dc} lines. This makes connection of the tether a simple matter of quite literally plugging the male of the extension cord into its matching female end.

Since the length of the tether is over 15 meters 'ohmic' losses make the conversion of the 48V_{dc} to 12V_{dc} at the surface problematic. In order to overcome the voltage loss, which depending on the current draw could be up to 2 volts, the full 48V_{dc} source is transmitted to the ROV. In order to step down the voltage to twelve volts a DC/DC converter is used (EUMFD60Y12A). This power converter can provide 600 watts of power at 12 volts. The output of this voltage converter is isolated from the input, which means that the ROVs electronics are isolated from the surface side power systems and faults.

In addition to providing power to the ROV the extension cords third conductor has been used for data communication to the ROV. A 4N25 optical isolator has been configured to both to convert the RS232 serial signal to TTL levels for the micro-controller, and to ensure no grounding loops occur between in the input of the power brick and its output. Figure 3 shows the electrical details of the tether.

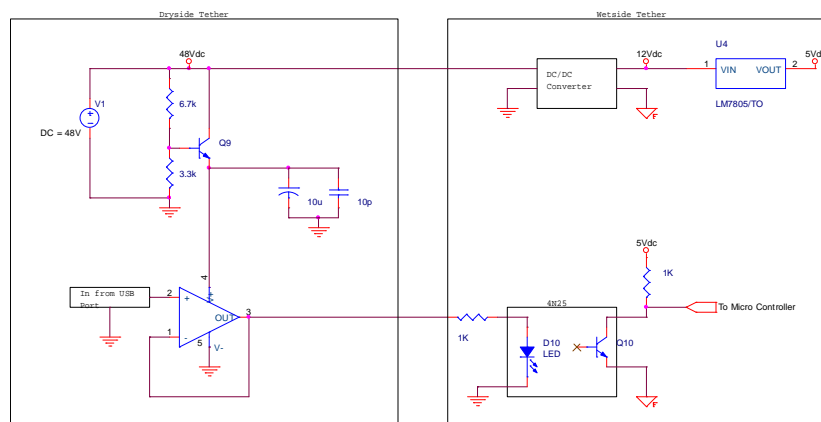

Figure 3: Tether Schematic

While the current tether is sufficient for the *Black Pearl*, two opportunities for future improvement have been identified. First, the addition of a second control wire for bi-directional communication, allowing the ROV to return telemetry information to the surface to aid the pilot's awareness of the vehicle's condition and environment. Secondly, the FishTV tethers and main power / communications line could be integrated to streamline the overall tether.

Power Box

One of the unique problems faced in the design of the power system was to create a $48V_{dc}$ supply which could be easily transported and maintained.

Since the ROV can potentially draw $30A_{dc}$ using standard wall outlet as a power source by rectifying and transforming the $120V_{ac}$ to $48V_{dc}$, this was not an option as wall outlets are normally only rated for $15A_{ac}$ draw. Therefore in order to obtain the appropriate levels of voltage and current, four batteries have been used. However maintaining a $48V$ battery bank is problematic as most battery chargers can only provide $12V$.

In order to overcome the challenge of providing both a forty eight volt supply while at the same time being able to keep the batteries in good condition we installed a bank of power relays in our power distribution box. Under normal operations of the ROV the relays are unpowered and set in their closed position, which connects the four batteries in series. However, upon completion of activities we can plug our distribution box into a standard wall outlet and actuate the relays so that the batteries are then wired in parallel. While in parallel, a standard $12V$ $2A$ battery charger can maintain the batteries. Figure 4 details the power box electrical schematic.

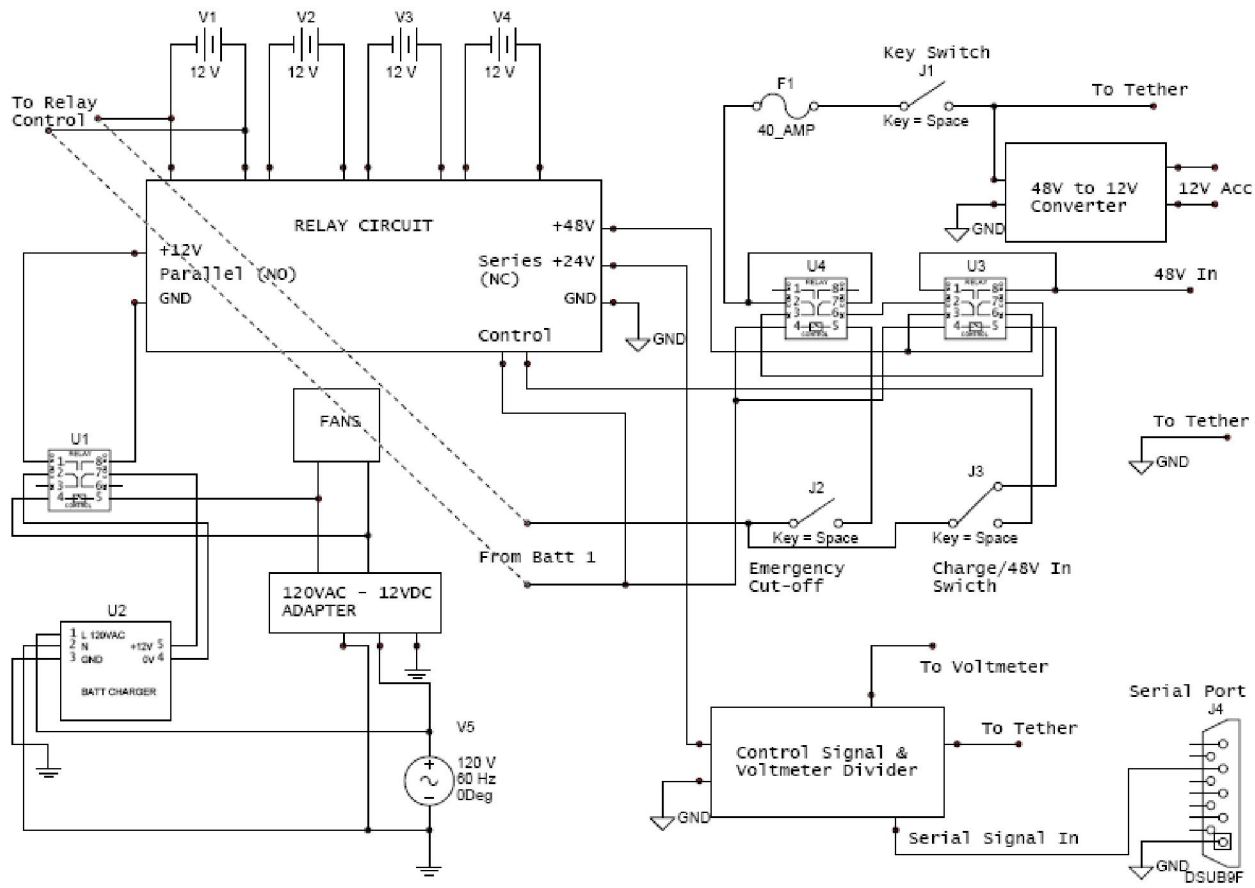

Figure 4: Schematic of Power distribution box

We have also included several safety features in the design of the power distribution box to ensure maximum safety. The positive rail of the 48V tether has been fused with a 40A resettable breaker, a master battery key, and an emergency kill switch. Since the MATE competition will be providing their own power supply during the competition a relay has added prior to these safety features, which can be actuated in order to disconnect our power internal power supply and allow us to power our ROV completely from the provided one. In order to ascertain the general condition of the box several indicator devices were added to the face plate of the power box, as shown in figure 5.

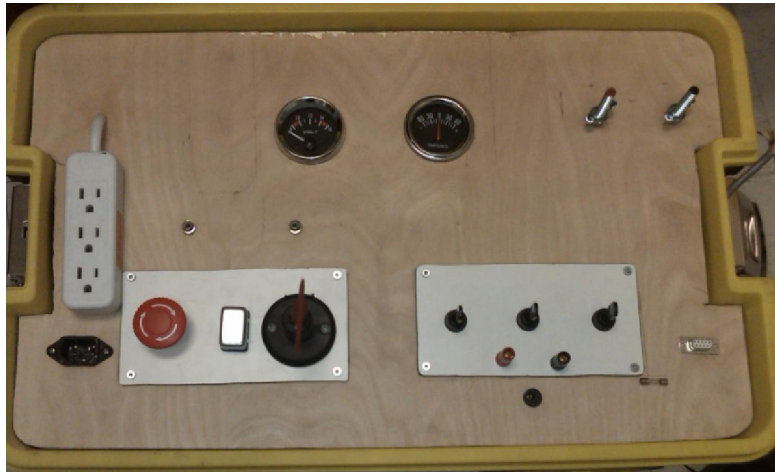

Figure 5: Box Faceplate

A one quarter voltage divider circuit read into an operational amplifier in a buffer configuration allows us to observe voltage applied across the tether on a 20V analogue meter. Also we have included a current meter rated for 60A in order monitor the electrical current flow in the tether. Two LEDs are present to indicate the status of the tether. The red LED indicates that an external power supply is being used while the green indicates that the tether is live to the ROV.

Camera Mounts

In order to ensure that our cameras are stable when the vehicle is in operation, but allow flexibility in orientation, we designed our own camera mounts. The final design was then manufactured using the Dalhousie Mechanical Department's rapid prototype machine. A ball joint was included in the design which allows for maximum flexibility of camera orientation.

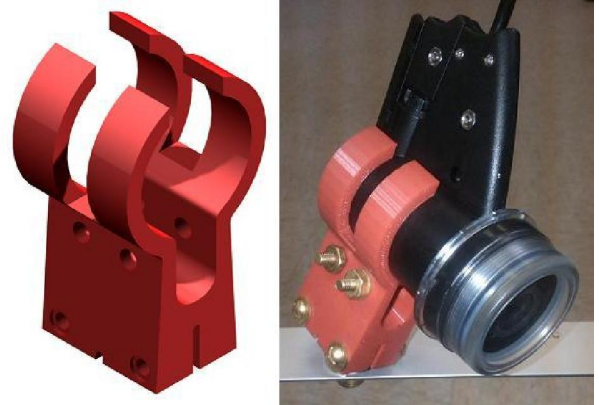

Figure 6: Camera Mount

Onboard Electronics

The onboard electronics system for the Dalhousie ROV consists of 3 separate circuit boards:

1. Micro-controller Board
2. Octal Unidirectional Motor Control
3. Dual Multidirectional Motor Control Board

Each of these boards is powered independently of each other from the main twelve volt out of the power brick mentioned in the tether system. This modular approach makes it very easy to change out components from year to year as required.

Micro-Controller Board

The micro controller board is the main control centre of the onboard electronics. Consisting of a pic16f877 micro-controller, LM7805 voltage regulator, and a 4N25 optical isolator this board responds to the control information sent from the pilot.

Since the 4N25 is a relatively slow optical isolator it was determined that a serial stream of about 2400 baud was all that it could sustain reliably.

In order to be able to determine the output state of the micro-controller, LEDs were placed in parallel with the output pins. This allows for at a glance micro-controller trouble shooting.

Octal Unidirectional Motor Control

This board contains two banks of four unidirectional motor controllers as shown in Figure 7; each bank has an optional PWM input pin which can be used to modify the average voltage applied to the motors. One bank of these controllers is dedicated solely to energizing the vector drive bilge pumps, while the other is used to actuate various tools.

Each controller uses a NAND gate coupled with a 2N3904 in order to drive a MOSFET. One pin of the NAND gate is tied to a shared PWM input pin with 4 others; this pin is pulled up through a 10k resistor in order to make its connection totally optional. The other input is connected to one of the micro controller pins in.

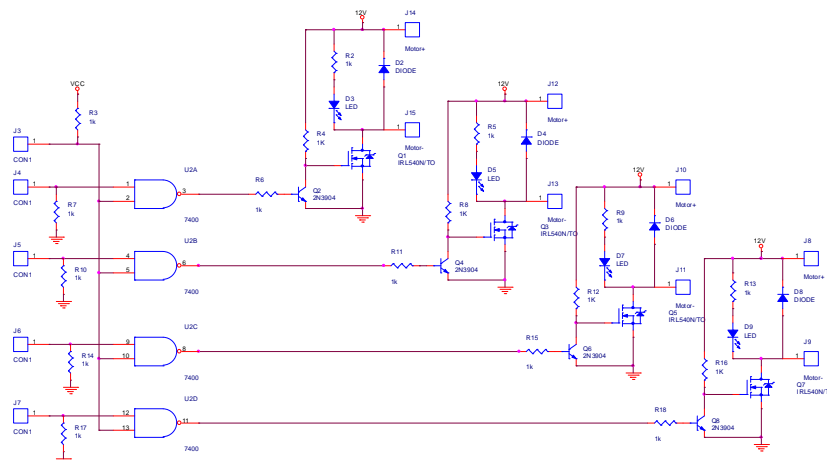

Figure 7: Schematic of 1 bank of unidirectional controller

Multidirectional Motor

The original intent of designing and constructing our own multi-directional controller board had to be abandoned due to time constraints. However, Figure 8 details its schematic to show that given more time we would have been include this in our final design. The schematic below allows for 2 pin control of a permanent magnet DC motor. The directional pin determines the direction in which current would flow, while the enable pin can be pulsed in order to achieve speed control of the motor.

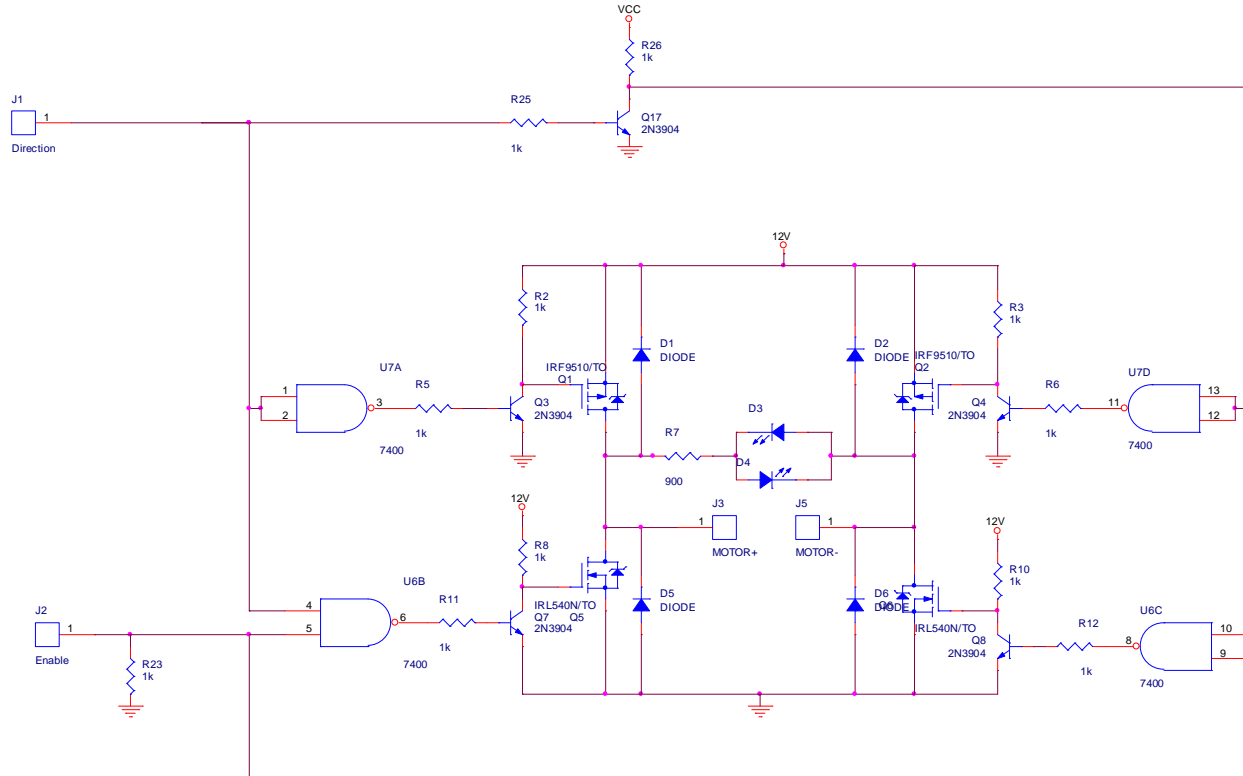

Figure 8: H-bridge with two input pin control

The dual H-bridge controller being used by the Dalhousie ROV is a Pololu Dual Motor driver. The board contains 2 H-Bridges which may be used to control both of the Bi-direction motors on the ROV. The board originally was controlled by a 3 pin interface an enable/PWM, A direction, and B direction. However, since A and B can never be engaged at the same time, we have installed an inverter between the two directional pins. This arrangement allows us to control each H-bridge with only 2 pins since whenever a high is set on one pin a low will appear on the other.

Software

All of the software used to control our ROV was created using a combination of the C and C++ programming languages. The user interface with the vehicle consists of a laptop and X-box 360 controller gamepad, while the onboard electronics are controlled by the PIC micro-controller.

An X-box 360 controller was chosen as the primary method of control in order to ensure the operation of the vehicle is as intuitive as possible. Figure 9 shows the basic flow of the user interface program.

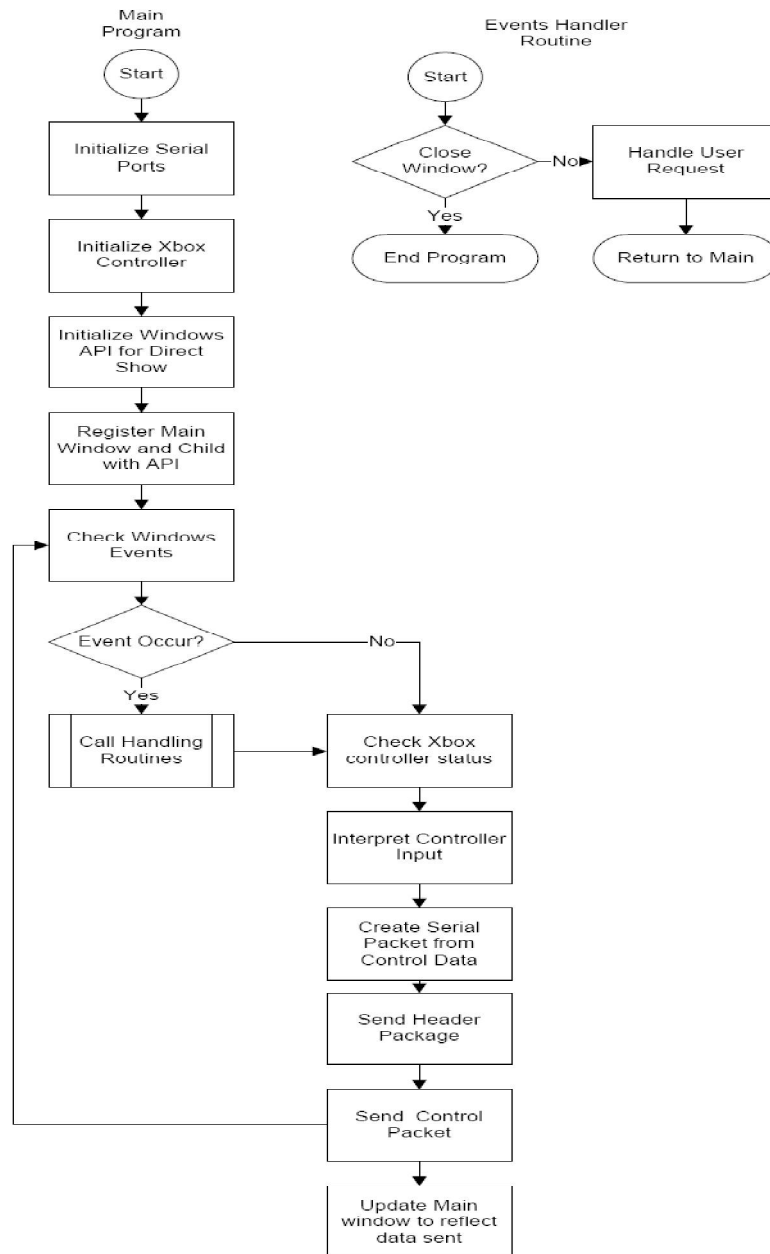

Figure 9: Software flow chart for User Interface

The micro-controller chosen for the onboard electronics is a PIC 16F737. This micro-controller features an on board 8MHz internal oscillator, 3 PWM output pins, a integrated UART, and has four 8 bit ports, meaning we have been able to keep the design of this master controller board as simple as possible. The micro-controller has been coded in C with a minimal amount of in line assembly code. Figure 10 is the basic flow of the microcontrollers program and error handling method.

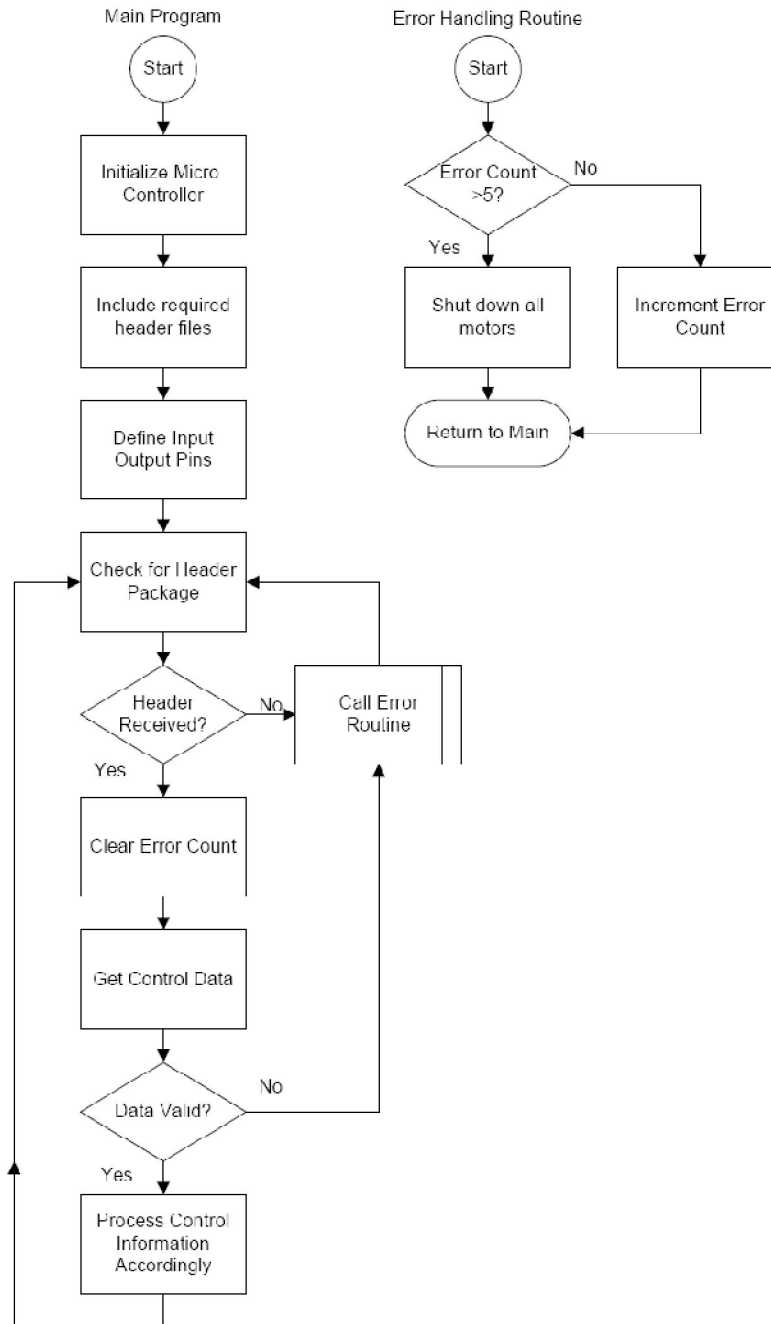

Figure 10: Onboard software flow diagram

Video Interface

In order to comply with the competition rules regarding the maximum number of monitors allowed we have reverse engineered the video input of our FishTV cameras systems. By removing the original CRT monitors were able modify the cameras original tethers to output to a standard RCA jack.

Tools

The Black Pearl's tooling systems were designed to allow the ROV pilot to accomplish the mission tasks with minimum manoeuvring in order to conserve time.

Multi-Purpose Brush

A gearbox motor mounted front and center on the Black Pearl drives a 20cm wire brush. This brush spins in the vertical plane and is used to rotate the supply hatch door through contact friction between the wire brush and the top of the hatch door. There is also a small peg protruding 4cm at a radius of 5cm from the center of the brush. This peg is used to manipulate the airline control valve. This integrated brush-and-peg design was chosen because it allows one motor to accomplish two functions, decreasing weight and complexity.



Figure 11: Brush

Pod Transfer Hooks

The most efficient way to move the ELSS pods from the carousel to the supply hatch is to move them all simultaneously. However, the small size of the hatch means the pods must be individually dropped into the hatch. The Black Pearl is able to transport all five pods from the carousel and drop them individually into the hatch through the use of three independent rotating hooks. The hooks are positioned such that the pilot may pick up all five pods in one motion. The hooks are equipped with latches to prevent premature pod release during travel. When positioned above the hatch, the pilot may activate each of the three hooks in turn, causing them to rotate down 20° and release either one or two pods into the hatch. The hooks are spring-loaded such that once the pods are released they will return to their original configuration, in case a pod misses the hatch and must be retrieved.



Figure 12: Hooks

Airline Insert Alignment System

One of the most intricate mission components is the insertion of the airline insert into the submarine airline connection. To aid the pilot in properly positioning the craft, a locator guide is attached to the front of the Black Pearl. The locator allows the pilot to properly position the ROV without fear of overshoot. Once the ROV is in the correct position, the airline insert is released from a shaped guide mounted at the same 45° angle as the submarine connector. This guide causes the airline insert to drop directly into the airline connector. The Black Pearl is designed such that the frontally-located motor (as described in the Multi-Purpose Brush section) uses a peg to manipulate the airline valve *without having to reposition the ROV*. When the valve has been opened and closed, the airline insert is removed through the use of a simple wire circle positioned directly above the airline connector. This interconnected system allows the Black Pearl to complete virtually the entirety of the airline insert task without repositioning the ROV.

Escape Hatch Cover

The escape hatch cover was mounted on the rear underside of the ROV; this allows the pilot to settle the bottom of the ROV onto the top of the submarine during the mating process. Such positioning will improve stability during the mating operation. An alternative design was to have a flexible accordion-style coupling that would compress as it mated with the hatch, providing an effective seal. This idea was discarded as it proved too difficult to restrain a flexible coupling during normal ROV operations.



Figure 13: Hatch Cover

Challenges Faced

One of the technical challenges we faced was the problem of opening the hatch 360 degrees. The idea of a robotic arm was ruled out as last year we created one, but it proved too difficult to manipulate. Many of the other ideas for solving this problem required complex manoeuvring of the ROV – causing it to turn a full 360 degrees. Finally, we decided on using a design incorporating a gearbox motor and a metal brush in order to turn the hatch.

Another challenge that we faced was managing our design schedule. The team all had entirely different class, work, and commuting schedules, meaning it was unusual to have the entire team present at any given meeting. To better manage this we divided into design groups based on interest and skills, and had periodic general meetings to keep everyone updated on the overall progress.

Troubleshooting Techniques

“**Troubleshooting** is a form of problem solving most often applied to repair of failed products or processes. It is a logical, systematic search for the source of a problem so that it can be solved and so the product or process can be made operational again”.¹

During one of the trial runs of the ROV we noticed that the ROV was moving very slowly in the water. Previously, the motor and bilge pumps had been functioning better and were manoeuvring the ROV through the water more quickly. Since the last trial run, several modifications had been made. The new tether had been added, the electronics box was installed, and a new control system was implemented. With these three new improvements there were a series of problems that could be causing the failure in the motor and bilge pumps.

1. The wires in the tether are damage causing a shortage in power.
2. The connections to the electronic box are faulty and causing power loss there.
3. The new control system was not working properly and causing the motor and bilge pumps to not run at full power.

After some careful analysis we noticed plating had appeared on the connection from the electronics box to the tether. We realized that the combination of exposed electrical connectors, two dissimilar metals, and chlorinated water created a perfect situation for electrolytic plating. This plating was the cause of our power loss, so we redesigned the tether connections to the electronics box to be water proof. These actions solved our power loss problems.

Lessons Learned and Skills Gained

Over the past months we have all have learned many lessons and gained many new skills. We have had a chance to apply what we have learned in class or our own readings to a real life project. Although for each of us the important lessons and skills are different, here are an example of one skill and a lesson we all learned:

A technical skill learned by our team is the ability to think outside the box to solve problems. In many of our challenges we had to come up with some strange solutions to solve our problems. Examples of this are using cameras designed for fishing in order to see under water, using a wire brush mounted in a vertical plane to turn the hatch, and positioning the airline insert and valve manipulators in manner that does not require any repositioning of the ROV during the airline task.

An interpersonal lesson we have learned and perfected is the use of communication such as email, text and Facebook in order to keep everyone on the same page. Our team is large and the different schedules made it hard to get everyone together at once, so using different forms of communication allowed us to keep track of everyone and everything.

¹ Wikipedia The Free Encyclopaedia, Edited on 11 May 2009
<http://en.wikipedia.org/wiki/Troubleshoot>

Reflections

We started off this year with few of us knowing each other and only members from last year's team understanding what we were attempting to build. For years we have been learning in classes, labs and from books what it is to be an engineer or a computer scientist, but this was the first time we truly had to apply what we have learned. All the study and work has paid off, as all of us put to practice what we have learned for years and built an ROV for submarine rescue. Our physics and mechanics classes have paid off as we built the frames and tool. The electronic, circuits and programming classes allowed us to create the power and software to run and control our ROV. We also managed to keep our cost down and collect a number of sponsors. All of us have learned skills and lessons and we will walk away with new abilities.

NSRS NATO Submarine Rescue System

The NSRS is an international submarine rescue team primarily run by the U.K, France, Norway and other NATO countries. The project is designed to provide aid to any NATO submarine at a moment's notice anywhere in the world.²

The NSRS is comprised of three separate steps. The first step is the IROV, Intervention Remotely Operated Vehicle, this machine is designed to locate the distressed submarine and establish communications with it. Then it will assess the submarine's damage, remove debris as needed, measure radiation levels and prepare for the rescue operations.³



Figure 14: IROV

² U.K British Royal Navy, 2009

<http://www.royalnavy.mod.uk/operations-and-support/submarine-service/future-submarines/nato-submarine-rescue-system/>

³ Jonty Powis, Stewart Little

http://www.ismerlo.org/assets/NSRS/NSRS%20Factsheet%20Issue%204%201%20lo-res1%20_2_.pdf

After these steps have been established the SRV, submarine rescue vehicle, will come into play. The vehicle can safely perform at depths reaching 610 meters, perform up to sixty degrees to the horizontal and rescue fourteen people per trip. Once the crew are safely inside the SRV they are returned to the surface. The third stage involves the TUP system, Transfer under Pressure, this can depressurize up to seventy-two people safely. TUP also has an environmental control facilities, oxygen storage and complex control centre needed to deal with rescues under pressure, and safely return the crew to the surface.



Figure 15: SRV Launch

Unlike most ROVs and rescue systems the NSRS does not have a mother ship. These mother ships are designed to deploy and retrieve the ROVs. The reason the NSRS does not have a mother ship is because it is instead design to be able to use any large ship that is closest to the distressed submarine. This allows the NSRS to be able to travel by land and air, reducing the time required for it to get to the submarine. It uses another system called the PLARS, portable launch and recovery system. This is a machine design to deploy and retrieve the various NSRS ROVs from the water and to adapt to various ships around the world.⁴

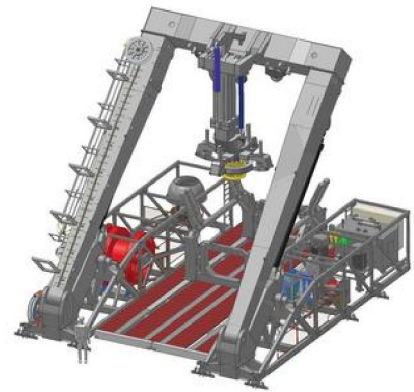

Figure 16: PLARS

Many of the tasks that the NSRS will perform are much like the missions that our own ROV is to be able to complete. It will have the ability to assess the damage to the submarine using the IROV much like the first mission in which our ROV must locate various damage points. Then the SRV will perform the rescue of the crew onboard the submarine which is like one of the last missions that our ROV must complete.

⁴ <http://www.ismerlo.org/assets/NSRs%20ISMERLO.pdf>

Photo Credits

Figure 14: An image of one of the ROVs that will be involved in the NSRS can be found on the UK royal navy website.

<http://www.royalnavy.mod.uk/operations-and-support/submarine-service/future-submarines/nato-submarine-rescue-system/>

Figure 15: The SRV being deployed by the PLARS of a ship.

http://www.sonistics.com/smer_update_ind.php?id=35

Figure 16: A model of the PLARS.

http://www.sonistics.com/smer_update_ind.php?id=35

Appendix A – Exploded view of core mechanical components

