

# **2009 Technical Report Underwater Robotics Research Team**

At

Embry Riddle Aeronautical University  
Prescott, Arizona

## **Technical Report for the Marine Advanced Technology Education Competition**



### **Team Members:**

Taylor Davis (JR., Aeronautical Science), Sam Douglass (Soph., Aerospace Engineer),  
Eduardo Moreno (JR., Mechanical Engineer), Cory Ravetto (JR., Aerospace Engineer),  
Rene Valenzuela (JR., Aerospace Engineer)

### **Faculty Advisor:**

John Nafziger PhD.

## Table of Contents

<b>Section</b>	<b>Page</b>
1.0 Abstract	1
2.0 Budget	2
3.0 Design Rational	3
3.1 Structure	3
3.2 Thrusters	4
3.3 Cameras and Sensors	8
3.4 Robotic Claw	10
4.0 Electrical Schematic	11
5.0 Software Flow Chart	12
6.0 Challenges	13
6.1 Control System Challenges	13
6.2 Thruster Challenges	14
7.0 Future Improvements	14
8.0 Submarine Rescue System	15
9.0 Reflections	16
9.1 Eduardo Moreno	16
9.2 Cory Ravetto	17
9.3 Rene Valenzuela	17
9.4 Taylor Davis	17
10.0 References	18
11.0 Acknowledgements	18

### 1.0 Abstract

This project constitutes Embry-Riddle Aeronautical University's first entry into the underwater world. Two of the team members have past experience with robotics, one of whom has built an RC submarine before. However, this project was to surpass all previous involvements in the robotics world in both scale and complexity, pushing the team to the limits of its ingenuity. The beginnings of the project date back over a year to our previous competition at the Nation Underwater Robotics Challenge held in Chandler, Arizona in 2008. There, the Embry Riddle team took first place at the University level.

## 2.0 Budget

<b>Expenses</b>				
	<b>Item</b>	<b>Qty.</b>	<b>Price</b>	<b>Total</b>
<b>Electronics</b>	Diamond Systems Athena II Board	1	\$1,025.00	\$1,025.00
	24V DC Motor Controllers	10	\$39.95	\$399.50
	IFI Controller (Donated)	1	\$0.00	\$0.00
	Misc. Electronics	1	\$140.00	\$140.00
	Underwater Camera (Donated)	1	\$0.00	\$0.00
<b>Thrusters</b>	Maxon 24V DC Motor	10	\$20.00	\$200.00
	Thruster Shaft Seals	11	\$13.24	\$145.64
	Thruster Needle Bearing	11	\$7.20	\$79.20
	Thruster U-Joints	11	\$8.09	\$88.99
	Thruster Propellers	10	\$6.25	\$62.50
	Underwater Connectors	12	\$60.00	\$720.00
<b>Hardware</b>	Polycarbonate Sheeting	1	\$303.12	\$303.12
	Misc. Polycarbonate	1	\$90.00	\$90.00
	Misc. Hardware and Materials	1	\$450.00	\$450.00
	Travel Expenses for Boston	5	\$1,160.00	\$5,800.00
			<b>Total</b>	<b>\$9,591.75</b>
<b>Funding</b>				
	<b>Source</b>			<b>Amount</b>
	Lockheed Martin			\$5,300.00
	Embry Riddle Aeronautical University			\$5,800.00
			<b>Total</b>	<b>\$11,100.00</b>

### 3.0 Design Rational

As with all great engineering feats, we started our endeavor by conducting an extensive research of existing vehicles. We then looked at the competition requirements for the MATE competition. In addition, we looked at the technical reports from prior competitions, which provided many ideas for design options. Our goal was to build a vehicle that could not only compete at MATE, but that could also compete at other underwater competitions.

#### 3.1 Structure

We began by selecting a base structure onto which all other components would be based on. We decided to start by focusing on a circular design with a large waterproof interior space. The circular structure and dome have better hydrodynamic properties than a box-shaped structure. A dome and cylinder also provide considerable structural strength. The watertight compartment is oversized to provide space for future improvements and to reduce costs by housing critical items, which would otherwise have to be individually waterproofed.

##### 3.1.1 Drag

In this section we considered the theoretical drag of our vehicle focusing on the two predominate shapes of our design, which are the dome and the cylinder. Drag is dependent on velocity, body size, and viscosity of the fluid. There is an abundance of data available in literature for drag coefficients ( $C_d$ ) of common shapes.

$$C_d \text{ Dome} = C_d \text{ Sphere}/2 = 0.235$$

$$C_d \text{ Cylinder} = 1.2$$

We used the drag equation (Eqn. 1) to calculate the force on a moving object due to the water's resistance. It is a very practical equation for calculating the drag experienced by an object due its movement in a static fluid.

$$F_d = \frac{1}{2} \rho v^2 C_d A \quad \text{Eqn. 1}$$

We set the velocity of our vehicle to be 0.25 (m/s) as this was the measured maximum speed of our vehicle during a strait-line pool test. We calculated that the force of drag associated with the vehicle's 36 cm dome as 0.73N and for the vehicles 10 cm tall cylinder as 0.38N, with a total drag of 1.11N. Since our vehicle contains more objects that contribute to drag besides the dome and cylinder we assumed the drag to be around 2N. By adding the vectors of the maximum 15N of force that we get from our thrusters at 0.25 (m/s) we were able to determine the resultant "pulling force" of our vehicle to be 13N.

##### 3.1.2 Materials

All major structural elements where constructed of clear acrylic or polycarbonate. This design feature was chosen because it allows the team to quickly find and diagnose any potential leak sources, or internal mechanical failures. The clear watertight compartment also offers virtually unlimited possibilities for positioning and mounting cameras.

After reviewing many different designs from past competition vehicles, we identified the need for an external structure that would provide mounting options for a variety of sensors, thrusters, and external mechanisms. We decided to adopt a double polycarbonate ring structure at the top and bottom of the cylinder. These two rings also help provide structural support by reinforcing

the two ends of the cylinder and by providing protection for the cylinder and thrusters. The rings also serve as a handle for transporting the vehicle when outside of the water.

A critical part of the design was the location of the access hatch. The access hatch is located on the bottom of the main cylinder. All entry points into the waterproof housing are located there with no other openings anywhere else on the vehicle. This provides us a measure of safety in case of failure, of the main seal or any of the other points on the hatch. All critical electrical components are also located high in the WTC, keeping them out of the water in case of leaks.

### 3.1.3 Stability

From a stability standpoint, we believe our cylinder and dome structure is one of the better design elements. Since virtually all of the weight of the vehicle is found on the 20lbs ballast weights the vehicle has a very low center of mass (Figure 1). The dome at the top of the vehicle provides a centered point of vertical buoyancy, which is 15.2cm away from the center of mass, creating a vehicle that is very stable in a water environment.

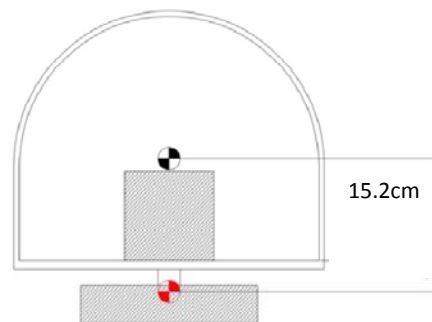

Figure 1: Location of Center of Buoyancy (black) and Center of Mass (red)

## 3.2 Thrusters

### 3.2.1 Price Constraints

When looking at other robotic designs, we found that one of the most expensive components of any vehicle was the thruster system. Typically, commercially available thrusters, in the size requirements we were looking for, sell for approximately \$700.00 which surpassed our budget capabilities. In lieu of this constraint, we opted to design and build our own thrusters. By making the thrusters ourselves, we were able to reduce costs to about \$100.00 in materials per thruster; a significant savings compared to commercial thrusters.

### 3.2.2 Construction

Choosing to make our own thrusters had several benefits. First, we were able to extend our learning options to not only include underwater structures, but also to include underwater propulsion systems. Another benefit of manufacturing our own thrusters was the ability to make a thruster that would be uniquely suited to our vehicle. Our first step was to select a motor that would fit our RPM, torque, and price requirements. Once the

motors were selected we designed the waterproof housing around them, and selected a suitable propeller (see Figure 2). The motors we are using are 24V, 5,300rpm dc motors manufactured by Maxon motors(bought off of EBay for a fraction of the retail price).The thrusters were then assembled and we moved on to our next step: testing.



Figure 2: Thruster Components

### 3.2.3 Testing

To determine actual thrust we conducted a Bollard test in a hydro tunnel (a graph of the results is provided at the end of the report). Our measurements revealed a pulling force of approximately  $6 \frac{1}{2}$  N (or  $1 \frac{1}{2}$  lbs) of force at full power. This force compares favorably with that of leading commercial thrusters, which produce around 10N (2lbs) of force at the same voltage.



Figure 3: Bollard Mechanism

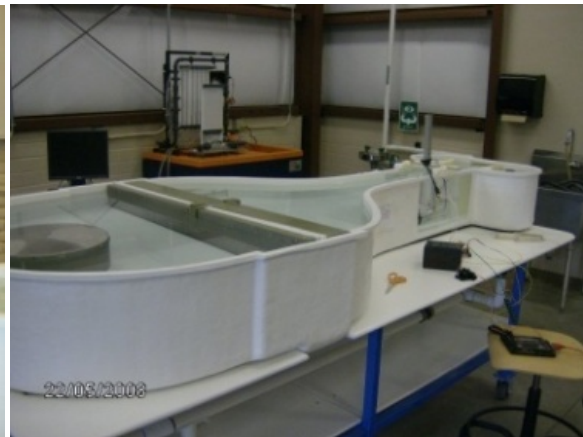

Figure 4: Hydro Tunnel

### 3.2.4 Thruster Configuration

The lateral thrusters are laid out in a diamond configuration. This layout allows us to vector forward and reverse thrust between the four angled thrusters allowing us to move in virtually any direction without having to turn the vehicle. However, in case turning is required, the capability to do so remains. Each thruster is attached to the vehicle with detachable waterproof connections allowing the operator to quickly exchange or remove

each thruster. In addition the thrusters are mounted with a single bolt which allows for quick mounting and un-mounting.

The diamond configuration of the vehicle's thrusters produces a net thrust in a given direction. This net thrust is the result of the combination of thrust from each of the 4 thrusters. The net thrust can be broken down into a summation of vector components that are contributed by each of the individual thrusters. Figure 5 below shows how vectors one through four are oriented. The vehicle has the ability to control both the magnitude and the sign direction of each of these thrust vectors. Three scenarios are outlined below.

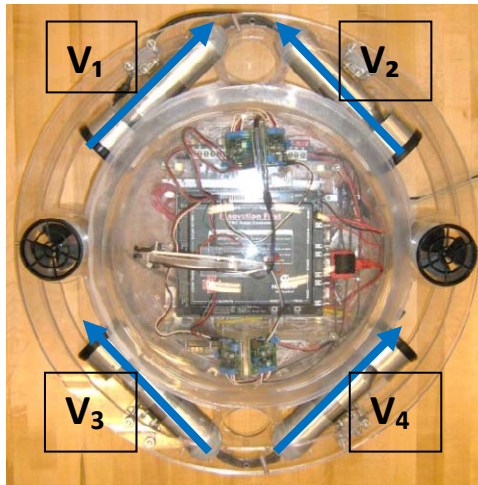

Figure 5: Thruster Vector Location

Scenario one is where the vehicle moves in a forward direction. All four of the lateral thrusters are activated. If we assume that  $V_n$  is a unit vector pointing in the direction of the thrust force, the magnitude of the thrust can be represented by  $V_n$ . The magnitude ( $V_n$ ) is the same for each thruster. For forward motion, the total thrust can be represented by the following equation:

$$V_T = V_1 \left( \frac{\hat{i}}{\sqrt{2}} + \frac{\hat{j}}{\sqrt{2}} \right) + V_2 \left( \frac{-\hat{i}}{\sqrt{2}} + \frac{\hat{j}}{\sqrt{2}} \right) + V_3 \left( \frac{-\hat{i}}{\sqrt{2}} + \frac{\hat{j}}{\sqrt{2}} \right) + V_4 \left( \frac{\hat{i}}{\sqrt{2}} + \frac{\hat{j}}{\sqrt{2}} \right) \quad \text{Eqn. 2}$$

since  $V_1 = V_2 = V_3 = V_4 = V$ , Equation 1 simplifies to:

$$V_T = 4 * V \left( \frac{\hat{j}}{\sqrt{2}} \right) \quad \text{Eqn. 3}$$

As can be seen from equation 3, the total thrust from all four thrusters is pointed in the positive Y direction as a result of the cancelation of thrust in the X directions. The net movement of the vehicle will therefore be in the Y direction. Figure 6 illustrates this principle with a vector field.

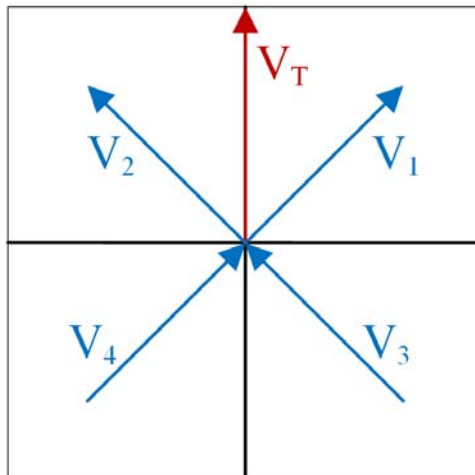

Figure 6: Forward Motion Vector Field

If all of the thrust values are reversed, that is, if both the  $i$  and  $j$  components are negated in equation 2, the net effect would be a thrust vector pointing in the negative  $Y$  direction yielding backward movement of the vehicle.

There are two options for sideways movement: the first is in the  $x$  direction only. This occurs when the four lateral thrusters are aligned as shown below in Figure 7. Note that this graphic is the same as Figure 6 except the  $V_2$  and  $V_3$  vectors are negated.

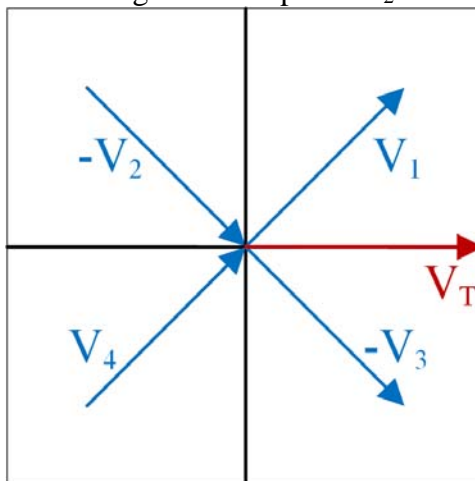

Figure 7: Sideways Vector Field

The net thrust equations can be represented as:

$$V_T = V_1 \left( \frac{\hat{i}}{\sqrt{2}} + \frac{\hat{j}}{\sqrt{2}} \right) + V_2 \left( \frac{\hat{i}}{\sqrt{2}} + \frac{-\hat{j}}{\sqrt{2}} \right) + V_3 \left( \frac{\hat{i}}{\sqrt{2}} + \frac{-\hat{j}}{\sqrt{2}} \right) + V_4 \left( \frac{\hat{i}}{\sqrt{2}} + \frac{\hat{j}}{\sqrt{2}} \right) \quad \text{Eqn. 4}$$

$$V_T = 4 * V \left( \frac{\hat{i}}{\sqrt{2}} \right) \quad \text{Eqn. 5}$$

Net thrust is therefore in the positive  $x$  direction pushing the vehicle in sideways direction.

The final option for movement is in a diagonal direction. If thrusters on opposite sides of the vehicle are turned off, diagonal movement in the x-y plane is possible. For example if  $V_2$  and  $V_3$  are set equal to zero as shown in Figure 8, the following thrust equations can represent net thrust of the vehicle:

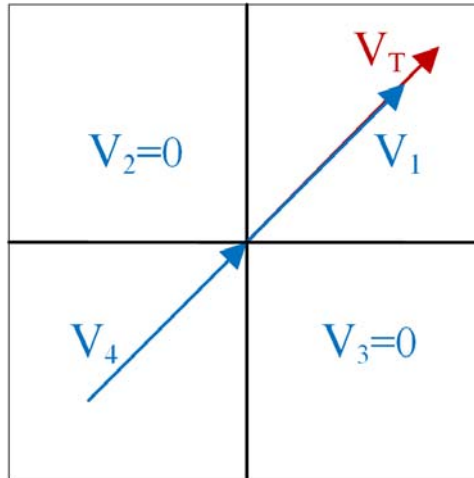

Figure 8: Diagonal Vector Field

$$V_T = V_1 \left( \frac{\hat{i}}{\sqrt{2}} + \frac{\hat{j}}{\sqrt{2}} \right) + 0 \left( \frac{\hat{i}}{\sqrt{2}} + \frac{-\hat{j}}{\sqrt{2}} \right) + 0 \left( \frac{\hat{i}}{\sqrt{2}} + \frac{-\hat{j}}{\sqrt{2}} \right) + V_4 \left( \frac{\hat{i}}{\sqrt{2}} + \frac{\hat{j}}{\sqrt{2}} \right) \quad \text{Eqn. 6}$$

$$V_T = 2 * V \left( \frac{\hat{i}}{\sqrt{2}} + \frac{\hat{j}}{\sqrt{2}} \right) \quad \text{Eqn. 7}$$

The net thrust will therefore result in a diagonal movement of the vehicle due to the combined thrust in both the i and j directions seen in Equation 7.

The three examples outlined above are for movement in the forward/reverse, sideways, and diagonal directions. However, since the vehicle is controlled by a joystick, the operator can vary the direction of the net thrust to include an infinite number of net thrust unit vectors that can point in any direction in the x-y plane. This coupled with the ability to control the net amount of thrust magnitude allows the vehicle to move freely in any direction and at any speed in the x-y plane without introducing rotation.

### 3.3 Cameras and Sensors

The sensor fit on the vehicle is composed of three cameras. A thermometer, hydrophone, and depth sensor have also been designed and built for the vehicle; however, since they are not required for this competition they will not be covered in this report.

The first camera is a Supercircuits PC180XS (lower left). This black and white camera has a 0.0003 lux level rating, which allows the camera to operate in near-total darkness. This camera is mounted on a GWS G125 sail winch servo, which allows the camera to rotate a full 360 degrees, allowing it to make full use of the acrylic dome and giving the pilot a great view of the underwater environment.



Figure 9: PC100XS Camera

The second and third cameras are PC100XS. While nowhere near as capable as the 180XS, these cameras were chosen for their very low cost. The first camera is mounted inside the vehicle facing downward toward the bulkhead in such a way that allows the pilot to control one of the robotic claws to pick up the required props and to assist the vehicle with the docking procedure.

The third and final camera is a Lights Camera Action LCA-7700-C underwater low lux camera. This camera was won by the team at the 2008 National Underwater Robotics Challenge in Chandler, Arizona. Since this camera is housed in a waterproof case, it can be mounted externally on any part of the vehicle.

All camera power connections and video signals will be routed directly to the surface. The pilot will be able to select from each of the three signal inputs on a television monitor at the control area. Originally, the team planned on using a PC104 Video Capture Module in conjunction with the Athena II computer to process video. This setup would have eliminated 3 cables from the vehicle tether resulting in less drag. However, since the Athena II computer is no longer available, and since the Video Capture Module is not compatible with the Innovation First Controller, the camera cables are run directly to the surface, bypassing the robot controller entirely. While not an ideal setup, the system worked well as a backup plan. In the future, when the Athena II computer is back in use, the camera signals will be run directly through the main robot operating system, streamlining the vehicle's wiring and controls.

### 3.4 Robotic Claws

The final major component of the vehicle is the robotic arm. The arm will be mounted on the outside of the vehicle and have its own separate waterproof electronics housing. The claw will be used to manipulate levers and open and close doors underwater. It can also be used to transport materials from the surface to an underwater environment or vice versa.



**Figure 10: Claw Mounted on the Vehicle**

The arm is powered by an RC servo connected to a pulley system to open and close the claw. This system was chosen due to its simplicity and ease of programming. The grabber is mounted to the vehicle with a two axis joint which allows for manual adjustment of the grabber to allow the picking up of rods that are either horizontal or vertical.

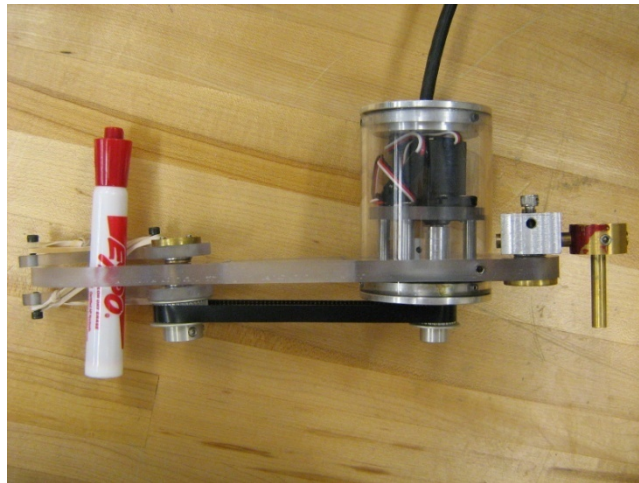

**Figure 11: Claw Servo Mechanism**

The servo is housed in a polycarbonate tube with aluminum end caps that contain a shaft seal. These tubes allow the user to quickly identify any potential leaks or mechanical problems. An underwater connection extends from one side of the servo end cap and connects to the underside of the vehicle with a bulkhead connector allowing for quick and easy mounting. The entire arm is mounted on a polycarbonate plate, which has several brackets. This bracket allows the team to mount the claw any place on the vehicle. The claw was not only cost effective, but it is also highly versatile.

## 4.0 Electrical Schematic

The following electrical schematic details safety features of the robot. The entire robot is protected by a 40A breaker and individual components are protected by fuses to ensure that both the entire electrical circuit and individual electronic components are protected in the event of a short-circuit.

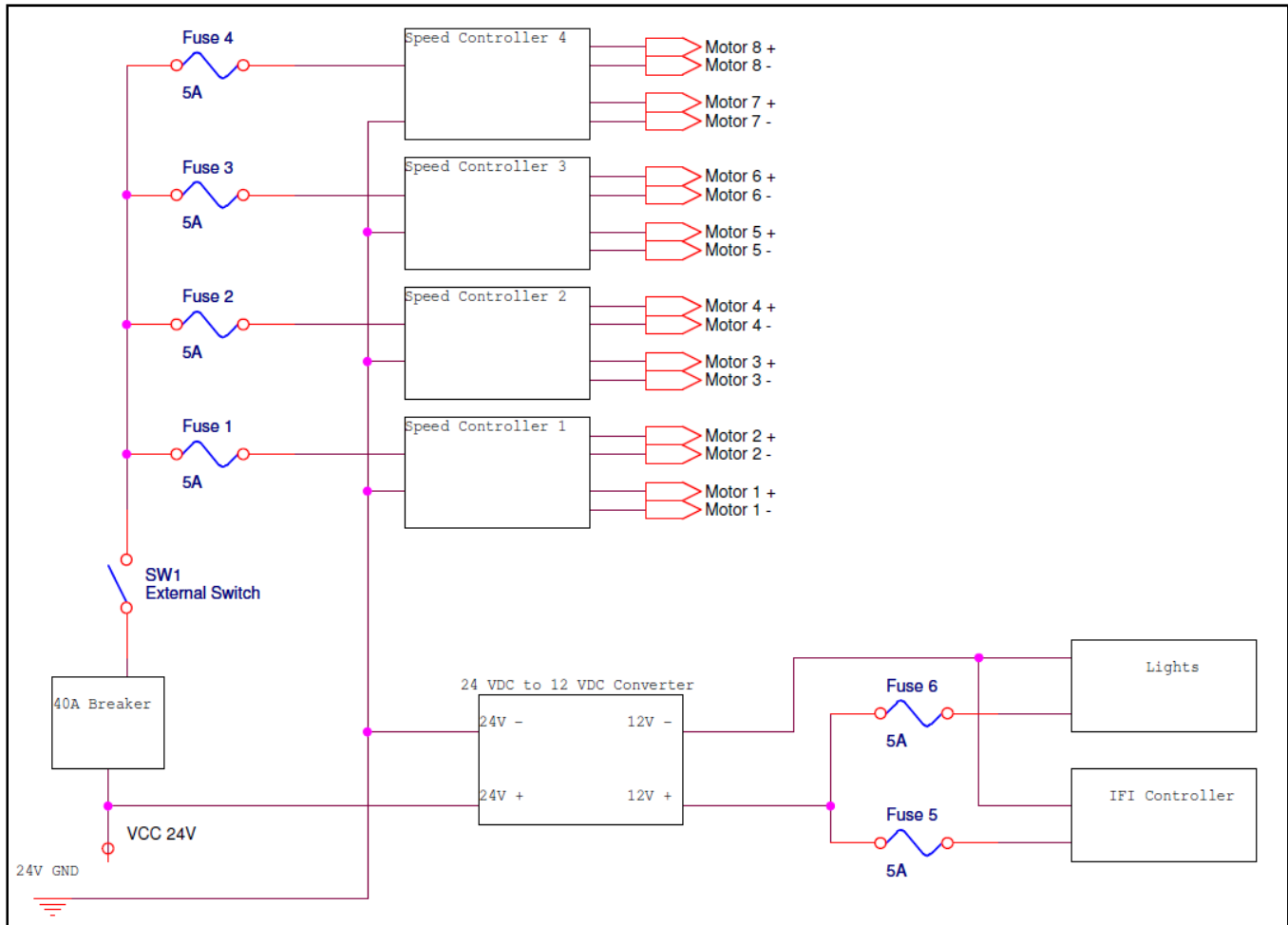

Figure 12: Electrical Circuit

## 5.0 Software Flow Chart

The team's original goal for this year was to use a Diamond Systems Athena II single board computer for the robot control system. This system would have allowed the team to create their own operating system to load onto the computer to control the robot. Unfortunately, a laboratory accident caused the Athena computer to be damaged beyond repair. Had the team been able to utilize the Athena controller, they would have created an operating system using Mathworks software. A Simulink control model would have been created using a graphical user interface. In addition to the Simulink software, Matlab coding would have been used to control specific functions within the Simulink control model. Due to limited time and funding, the team had to revert back to an older control system. Previously, the team used the Innovation First Robot controller. This system, while less capable than other controllers,

allowed the team to utilize a backup system after a failure of the main robot controller. The Innovation First controller uses C coding language and a much more simplified control algorithm (See Figure 13).

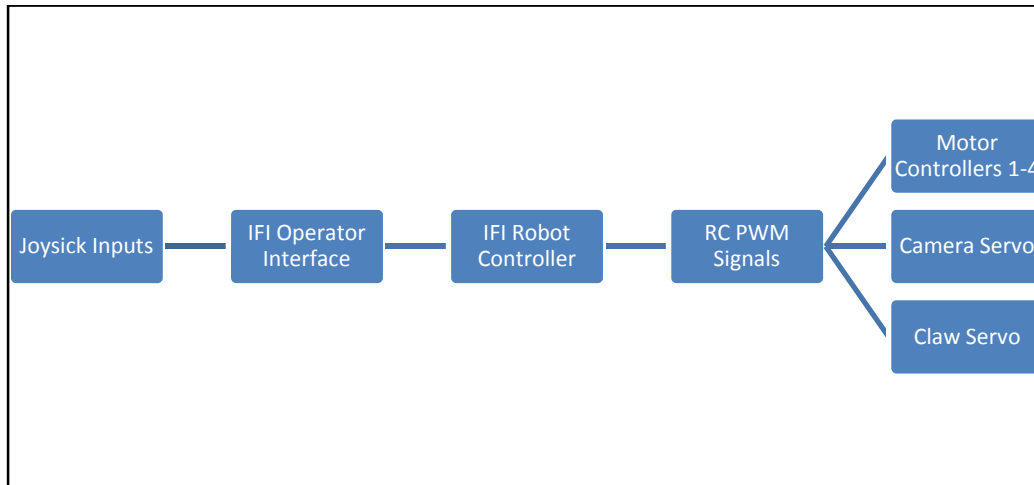

Figure 13: Control Algorithm

## 6.0 Challenges

### 6.1 Control System Challenges

One of the biggest challenges the team faced this year, and perhaps the most disappointing challenge, centered on the control system. Originally, the team wanted to use a single board PC104 style computer to control the vehicle. The goal was to use an Athena II computer from the Diamond Systems Corporation. This computer would have allowed the team to program their robot using a software combination of the Simulink graphical user interface and the Matlab coding language from Mathworks. This setup would have allowed the team to control the robot with a greater variety of control input devices making operation more intuitive. The Athena board would have also allowed the team to integrate video feeds from the vehicle directly into the control system for viewing on a computer monitor instead of a separate Television based circuit. The team purchased an Athena board and had a working control model that was about to be implemented on the vehicle.

Unfortunately, disaster struck and the Athena board was damaged beyond repair only 2 months before the team's first competition. With a limited budget, the team had to revert back to an older, less capable control system. The team is currently using a 2005 IFI robotics controller from First Robotics Systems. This controller, which is programmed using C coding language, is able to satisfactorily control the robot, but not with as much ease as the team had originally planned.

With any electrical circuit, mistakes and errors are bound to happen. While the team was not able to achieve its goal of an upgraded control system this year, a backup system was in place to cover the accident. Having a backup system for any engineering project is extremely important: an idea that was emphasized for the team this year.

## 6.2 Thruster challenges

One of the challenges we encountered when testing the vehicle was minor leakage in the thrusters. This leaking was due to the shaft wobbling where the shaft seal is found.

To fix the problem we replaced the ball bearing on each thruster with a needle bearing to keep the shaft in line with the seal. The shaft seals were also replaced. Industrial grade PTFE seals with better friction-to-pressure sealing capacity replaced the older rubber seals.

While testing the vehicle in the pool, a wire accidentally became entangled in the spinning propeller, which destroyed the propeller. We then identified the need for a mechanism to protect the propellers.

The solution we found was to place a grid on the back end of the propeller shroud. This part was made in a 3D prototyping machine. Several designs were considered and the best one was selected based on its strength and the least amount of drag it produced in the water.



Figure 14: Thruster Grid

## 7.0 Future Improvements

One of the primary design requirements was to provide for future upgrades. The vehicle was deliberately made larger than required to allow future equipment to be fitted inside. The motor housings were also scaled to allow motor upgrades. Several areas have been selected for future improvements. These include, the vision system, control system, tether, and ballast systems.

The first and most ambitious project involves the vision system. With the large internal space provided by the dome, we intend to install a full 3D camera system, allowing full 3D vision along the entire upper hemisphere of the vehicle. The cameras would then be integrated into a motion sensing headset, where the pilot would need only to turn his head to where he wants to look and the cameras would follow. This would exponentially increase the capabilities of the entire vehicle by allowing more fluid control and a feeling of being inside the vehicle.

The second upgrade is the control system, this involves two parts. The Innovation FIRST controller is a great piece of equipment; however, it does have some limitations and is relatively bulky. The second part involves experimenting with different ways of controlling the vehicle instead of using joysticks.

The third improvement is the tether system. Our current tether includes two video cables and one signal cable. In the future we would like to reduce it to only one cable. Current options being explored include Ethernet cables and fiber optic systems. However, the choice of tether will greatly depend on the choice of control and vision systems.

The fourth improvement is to be the addition of a fully controllable water ballast system. This ballast system will eliminate the current steel weights involved in balancing the vehicle, while providing a secondary, backup, form of vertical control to the vehicle, and also compensating for the change in buoyancy due to water depth, allowing the vehicle to operate in deeper waters.

The fifth and final improvement is the integration of a laser rangefinder system. Two laser pointers are mounted angled inward in relation to each other. A camera is then used to see the light points made by the lasers. The distance ( $L$ ) between the points allows us to calculate the range to the object we are looking at. See Figure 10 for a diagram of the system. The system is not perfect as one would need the "object" to have a flat surface, which ultimately means that the lasers would have to be equidistant from the object.

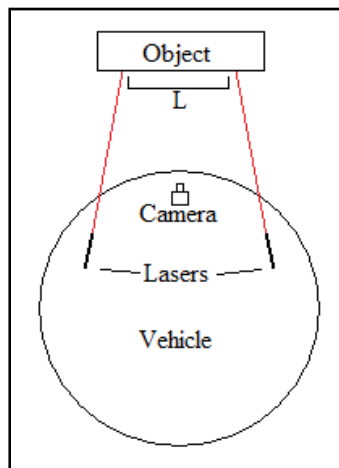
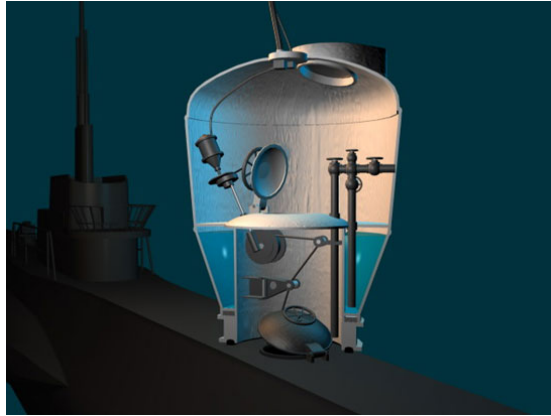

Figure 10: Laser Rangefinder System

Improvements to the motors, sensors and the vehicle itself are also being considered, however, they are beyond the scope of this report at the moment. While ambitious, we believe this program of upgrades to be within our capabilities. Even if we fail, the experience and knowledge we gain in attempting it will prove invaluable in this and other competitions, as well as in our engineering careers.

## 8.0 Submarine Rescue System

The McCann bell was the first operational submarine rescue system, and the only one that has been used successfully to date. The bell was developed by Lieutenant Commander Allen McCann as a result of the loss of S-4 in 1927. A few men survived inside the sunken submarine but the lack of a submarine rescue system prevented their rescue.



**Figure 15: McCann Bell**

Source: Dickie Burston Associates

The bell was simple in design and operation. Like the name states the system in is the shape of a bell with the main hatch on the bottom of the bell. It used the principle seen when an inverted cup is placed into a bowl of water. The air trapped inside the cup keeps the water from entering inside, and allows the bell to dock onto a sunken sub with ease.

The bell was transported aboard a converted minesweeper, and once the location of the sunken submarine was found the bell would be lowered and docked to the sub. The bell could hold a total of nine people per trip and so would require a number of trips to bring in all the survivors.

The McCann bell was successfully used in 1939 after the USS Squalus sank after flooding due to a faulty induction valve. In a rescue mission conducted over a period of thirty-nine hours, in squalls and bad weather, the McCann bell successfully rescued all thirty-three remaining crewmen of the Squalus. To this date, this remains the only successful rescue mission of a sunken submarine. An updated and more advanced version of the McCann bell still remains in service with the US Navy, as the Submarine Rescue Chamber.

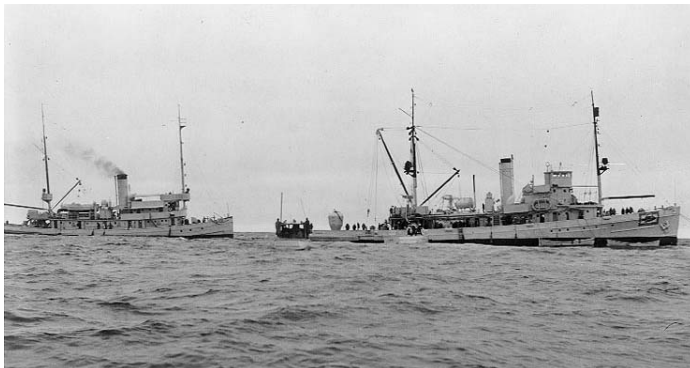

**Figure 16: USS Falcon and USS Wandank during rescue operations**

Source: Naval and History Heritage Command Website



**Figure 17: USS Squalus**

Source: Naval and History Heritage Command Website

## **9.0 Reflections**

### **9.1 Eduardo Moreno**

My interest in underwater vehicles began more than seven years ago. With the support of my parents I started to design and build RC submarines from scratch. Having no idea what these projects involved, I spent countless hours on the internet researching for a guide to get started. My dad proposed buying a model kit, but I knew that wouldn't do it. I had to design my own. It quickly became apparent that it was not a one-week project. The more problems that arose, the more I became enthralled with the venture. At the end of the project, I had learned how to use AutoCAD, how to use a majority of the machines at a fabrication shop, and how simplicity rules in engineering. My first submarine took two years, some burned electronic components, and several adjustments, but the calculations were right and it dived and rolled and gave me the spark to continue.

As the president of Embry Riddle's Underwater Robotics Research Team, I am continuing to pursue my creativity and passion for applied engineering. I enjoy the fact that being a member of this team has allowed me to share my passion in these undertakings with fellow students and great professors. This competition is the perfect venue for me to display my compilation of knowledge in the underwater robotics field. Up until this competition, I have learned the organizational challenges and responsibilities that go along with being a leader.

### **9.2 Cory Ravetto**

In addition to teaching me how to overcome obstacles, helping design a robot for an underwater competition has allowed me to gain experience with a hands on engineering task. As a junior Aerospace Engineering student at Embry Riddle Aeronautical University, this project has allowed me to apply engineering theories learned in the classroom to a real-life engineering challenge. Bridging the gap between theory and application is an invaluable skill I will need when I enter the industry workplace. This project has strengthened those skills for me.

As the chief programmer for the vehicle, the last couple of months leading up to the June competition were very frustrating for me. Losing our main robot controller, the Athena II computer, was disappointing for the team and for me especially. Working with the older C based controller has presented several programming challenges and limited the vehicle's functionality. However, I have come to understand the importance of having a backup system in place. As has happened to our team this year, one never knows when disaster can strike. Even though we lost our main controller, we had an older backup system that could quickly be converted into a usable controller for us. Without that backup system, it is possible our team would not have been able to compete at MATE. Failsafe systems are invaluable.

### **9.3 Rene Valenzuela**

This project has been a great learning experience for me. It has shown me what engineering is truly about. Not only has it shown me the fun and rewarding part of engineering, but has also shown me the difficult side. Deadlines, pressure, and budgetary concerns are all part of the

project at one time or another. While at the same time, teamwork presented its own problems with conflicting ideas and time schedules getting in the way. But even then I believe that it has prepared me for what I will face once I enter the work force as an engineer.

#### **9.4 Taylor Davis**

I have been an RC enthusiast for many years. This project has taught be many new things that I would have not otherwise learned in RC. I have now more appreciation for building something from scratch, as precise fabrication and much time goes into play. So as the only pilot coming into this venture without the engineering background has made me realize all that engineers go through as they design new things. I really enjoyed and learned from our brainstorming sessions. I have to say that I enjoyed the overall team experience.

## 10.0 References

1. Naval and History Heritage Command Website. Accessed 5-10-2009.  
<<http://www.history.navy.mil>>.
2. Fundamentals of Fluid Mechanics. Munson, Bruce R.; Young, Donald F.; & Okishi, Theodore H. John Wiley & Sons, Inc: New York, 2006, Fifth Edition.
3. Globalsecurity Website. Accessed 5-10-2009.  
<<http://www.globalsecurity.org/military/systems/ship/systems/src.htm>>.
4. Dickie Burston Associates Website. Accessed 5-10-2009.  
<<http://dbal.co.uk/images/rescue/rescue02-large.jpg>>.

## 11.0 Acknowledgements

We would like to acknowledge all those people and organizations whose help and assistance have made this project a reality. We greatly appreciate all of your contributions.

*Lockheed Martin*

*ERAU College of Engineering*

*ERAU Athletics Department*

*Carl Hayden High School & Fredi Lajvardi*

*Our Families*

*We would especially like to extend our thanks to the Marine Advanced Technology Education Center for hosting the 2009 International ROV Competition. Your efforts are greatly appreciated.*