

GEORGIA INSTITUTE  
OF TECHNOLOGY  
SAVANNAH

# GTS-ROV- $\alpha$

---

## GTS ROV Team

Dr. Fumin Zhang (Academic Advisor)

Justin A.S. Shapiro (Graduate Advisor)

Steven T Bradshaw

Angel Berrocal

Brandon Groff

Spencer Burch

Winton Key

Chasen Born

Matthew Carroll

Richard Nguyen

Jasmine Magerkurth

## Abstract

In January 2009, on the Savannah Campus of the Georgia Institute of Technology (GTS) a group of ambitious undergraduate students began coordinating their research efforts on the development of a Remotely Operated Underwater Vehicle (ROV). Though Georgia Tech's main campus hosts many competitive student engineering teams, this GTS-ROV initiative is both the first such group on the Savannah Campus and the first student underwater vehicle team at the Georgia Institute of Technology. Since its inception, GTS-ROV has strived to develop a research group and underwater vehicle deserving the prestige associated with the Institute, while uniquely identifying GTS from main campus in Atlanta. To achieve these goals, the team has been assembled from students in mechanical, electrical and computer engineering programs at varying stages of degree completion and a wide range experience in the disciplines of electronics and robotics. The group has designed a vehicle using a strategy of evolutionary acquisition, whereby the initial prototype is developed to fulfill an initial need and to serve as a starting point for subsequent redesign.

Before realizing the final design, several prototypes were built and tested to gain valuable experience with the constraints on a successful vehicle. Early designs included elaborate PVC frameworks wrapping pre-fabricated waterproof housings and revealed the importance of attaining neutral buoyancy and the benefits of a simple, fault proof hull. The resultant design, born in SolidWorks, consists of a fabricated aluminum tube dimensioned to optimize the ratio of internal mass to volume. The rear of the vehicle is equipped with a flange drilled with a circular bolt pattern. The vehicle is sealed by fastening a complimentary end cap to the flange. A shelf welded to the center of the end cap allows onboard electronics to be securely mounted, and easily removed for inspection.

The onboard electronics consist of systems for control, communication, and power electronics. The vehicle is controlled by software running on a National Instruments CompactRIO, which provides a pulse-width modulated signal for each thruster controller. A host computer on the surface communicates with the CompactRio via a Local Area Network connection which passes through a signal boosting network switch. Provisions for vehicle power, signal, and actuation of external loads consist of a combination of potted wiring and quick release through hull connectors. Onboard circuitry is protected by self-resetting circuit breakers chosen to prevent the loss of communications with the embedded computer, nominal current draw, and transient current induced during back EMF.

Mission specific hardware and software will be detailed throughout the report. A system of cameras is placed strategically around the vehicle for observing and completing missions.

# TABLE OF CONTENTS

ABSTRACT .....	1
ELECTRICAL SYSTEMS .....	3
SOFTWARE CONTROL SYSTEM.....	5
DESIGN RATIONALE: .....	9
CHALLENGES FACED .....	15
TROUBLESHOOTING METHODS .....	15
LESSONS LEARNED .....	16
FUTURE IMPROVEMENTS .....	16
SUBMARINE RESCUE ORGANIZATION PROFILE.....	17
REFLECTIONS.....	18
REFERENCES.....	20
ACKNOWLEDGEMENTS.....	20
APPENDICES.....	21
BUDGET/EXPENSE REPORT:.....	21
COMPACT RIO AND THRUSTER SPECIFICATIONS .....	23

## Electrical Systems

### **National Instrument's CompactRIO**

The CompactRIO is a programmable automation controller (PAC) used for advanced embedded control and data acquisition. CompactRIO has been designed for applications that require high performance and reliability. The CompactRIO is powered by National Instruments LabVIEW FPGA and LabVIEW Real-Time technologies which give engineers the ability to design, program, and customize the CompactRIO embedded system with easy-to-use graphical programming tools.

The CompactRIO combines an embedded real-time processor, a FPGA, and I/O modules. Each I/O module is connected directly to the FPGA. The FPGA is connected to the embedded real time processor via a high speed PCI bus.

### **C Series I/O Modules**

A variety of I/O types are available including voltage, current, thermocouple, RTD, accelerometer, and strain gauge inputs; up to  $\pm 60$  V simultaneous sampling analog I/O; 12, 24, and 48 V industrial digital I/O; 5 V/TTL digital I/O; counter/timers; pulse generation; and high voltage/current relays.

### **FPGA (Field Programmable Gate Array)**

A FPGA is a semiconductor device that is programmed using a logic circuit diagram or source code in a hardware description language (HDL). It can be used to implement any logical function. The embedded FPGA in CompactRIO is a high-performance, reconfigurable chip that can be programmed with LabVIEW FPGA tools. By using the FPGA hardware embedded in the CompactRIO, we can implement a custom control for the ROV ESC's analog input.

### **Real-Time Processor**

LabVIEW has built-in functions for transferring data between the FPGA and the real-time processor within the CompactRIO embedded system. It is also possible to integrate existing C/C++ code with LabVIEW Real-Time code to save on development time.

## Power Distribution

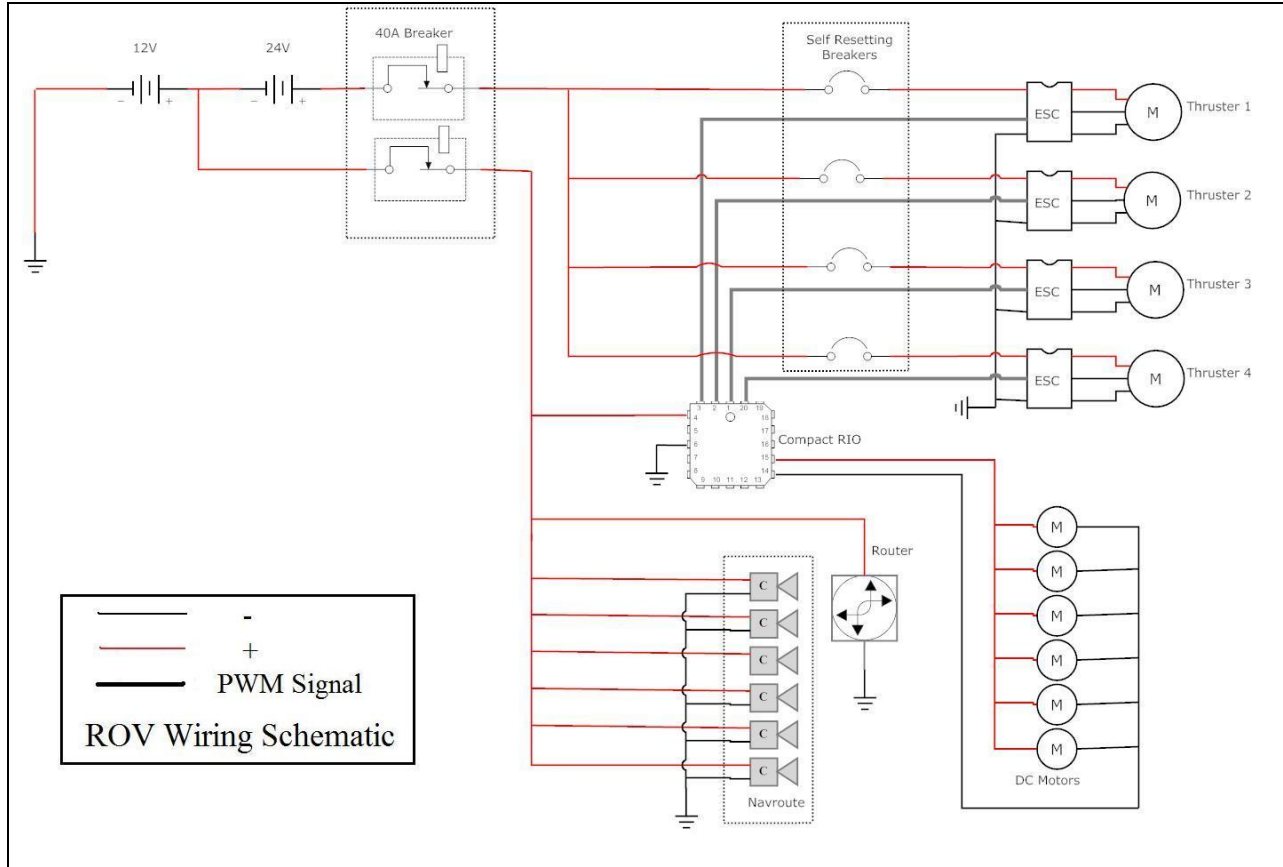

Figure 1 Electrical Schematic

## LabVIEW

LabVIEW (short for Laboratory Virtual Instrumentation Engineering Workbench) is a platform and development environment for a visual programming language from National Instruments called "G". LabVIEW ties the creation of user interfaces (called front panels) into the development cycle. LabVIEW programs and subroutines are called virtual instruments (VIs). Each VI has three components: a block diagram, a front panel, and a connector panel. The graphical approach also allows non-programmers to build programs simply by dragging and dropping virtual representations of lab equipment with which they are already familiar.

## PWM (Pulse Width Modulation)

To control the speed of a DC motor a variable voltage DC power source is needed. However, if the power to a 12 volt motor is switched on, the motor will start to speed up; motors do not respond immediately so it will take a small time to reach full speed. If the power is switched off sometime before the motor reaches full speed, then the motor will start to slow

down. If the power is switched on and off quickly enough the motor will run at some speed between zero and full speed. This is exactly what the ESC (Electronic Speed Controller) does: it switches the motor on and off in a series of pulses controller by a pulse width modulated signal.

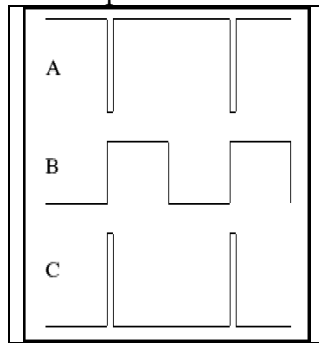

Figure 2 PWM examples

The figure above shows three different PWM signals. Figure A shows a PWM output at a 90% duty cycle. That is, the signal is on for 90% of the period and off the other 10%. Figures B and C show PWM outputs at 50% and 10% duty cycles, respectively. These three PWM outputs encode three different analog signal values, at 10%, 50%, and 90% of the full strength. If, for example, the supply is 5V and the duty cycle is 10%, a 0.5V analog signal results.

## Software Control System

### Phase I

Because the speed controllers require pulse-width modulated signals to control the thrusters, a simple Lab View module was created allowing four independent square waves to be generated with a variable duty cycle controlled by a text box. While this Lab View module was extremely simple and easy to test both software and the speed controllers and thrusters, it was not very intuitive for flying the ROV. A screenshot of the interface follows.



**Figure 3- Screenshot of GUI interface for Phase I thruster controller**

## **Phase II**

The next phase of software control improvements uses slider inputs (controlled by mouse or keyboard) to control the four thrusters. Buttons lock and allow control of two thrusters at once for ease of use, while sliders for turning and rolling allow a single mouse click that increases thrust to one thruster and decreases it to the other to perform the desired turn or roll. While this interface is much more intuitive it still does not allow great ease of control and requires quick keyboard/mouse movements for complicated ROV maneuvers.

The block diagram shown below displays two blocks that run in parallel. The top block is the logic and math used to manipulate the values received from the sliders to usable duty cycle percentage value inputs to the square wave generators for each thruster. This block also performs the logic required to turn or roll as mentioned previously. The lower block is the timing engine which receives data from the corresponding slider, feeds it to the square wave generator, and ties the generated square wave to the corresponding output pin of the output module on the CompactRIO. For simplicity purposes only one thruster timing engine is displayed.

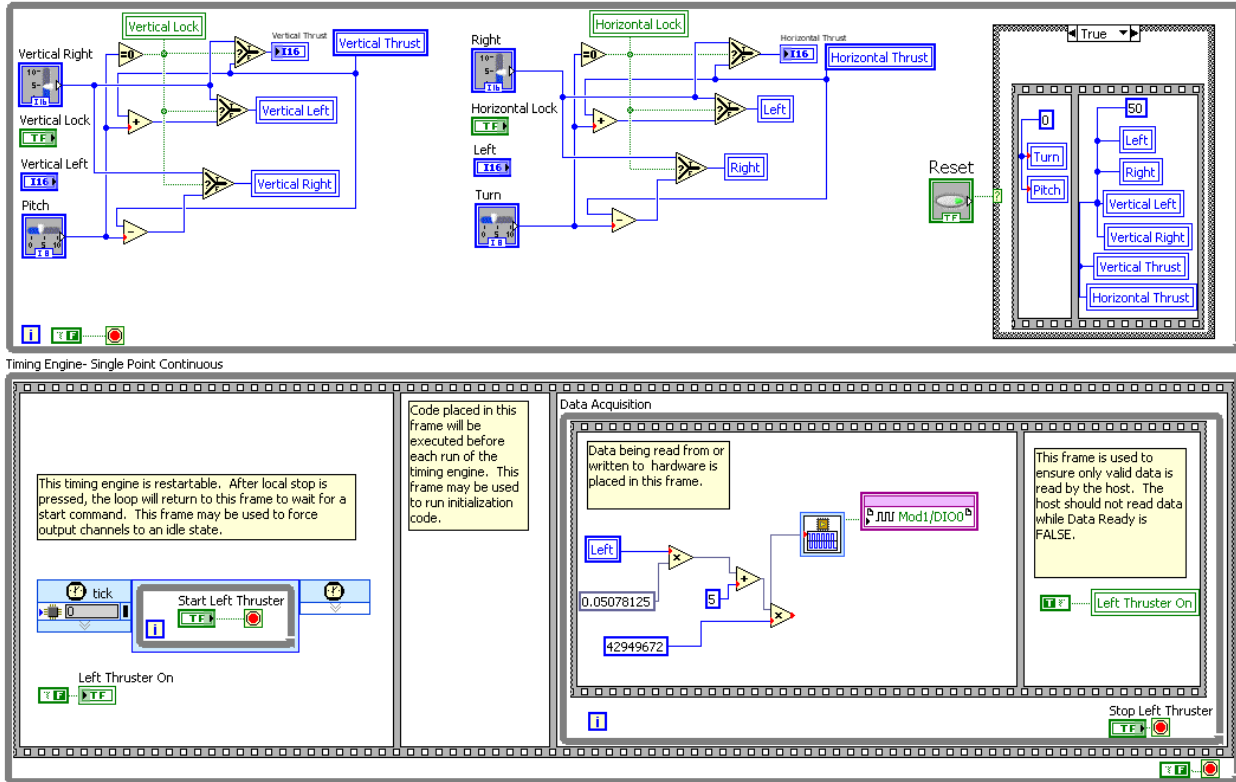

Figure 4-Lab View block diagram of control system and timing engine for a single thruster

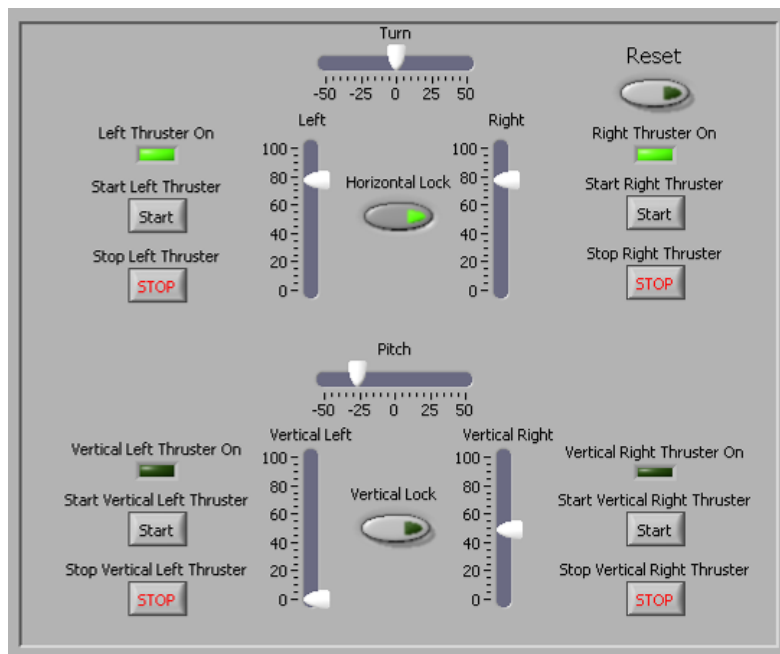

Figure 5-Screenshot of GUI interface for Phase II thruster controller

### Phase III

The next phase of improvement to the ROV control system is to replace the slider interface with a three dimensional mouse from 3dconnexion. This change will allow very intuitive movement of the ROV as well as be much faster than the software slider interface. An example of this technology is shown in Figure 7.



Figure 6 3D mouse control system<sup>1</sup>

<sup>1</sup> Image from <http://www.3dconnexion.com>

## Design Rationale:

### Hull

Several early hull designs were prototyped and tested throughout the life of this project. The early editions were frames made of 1'-PVC constructed around a Pelican waterproof box. A few of these are shown in Figure 8.

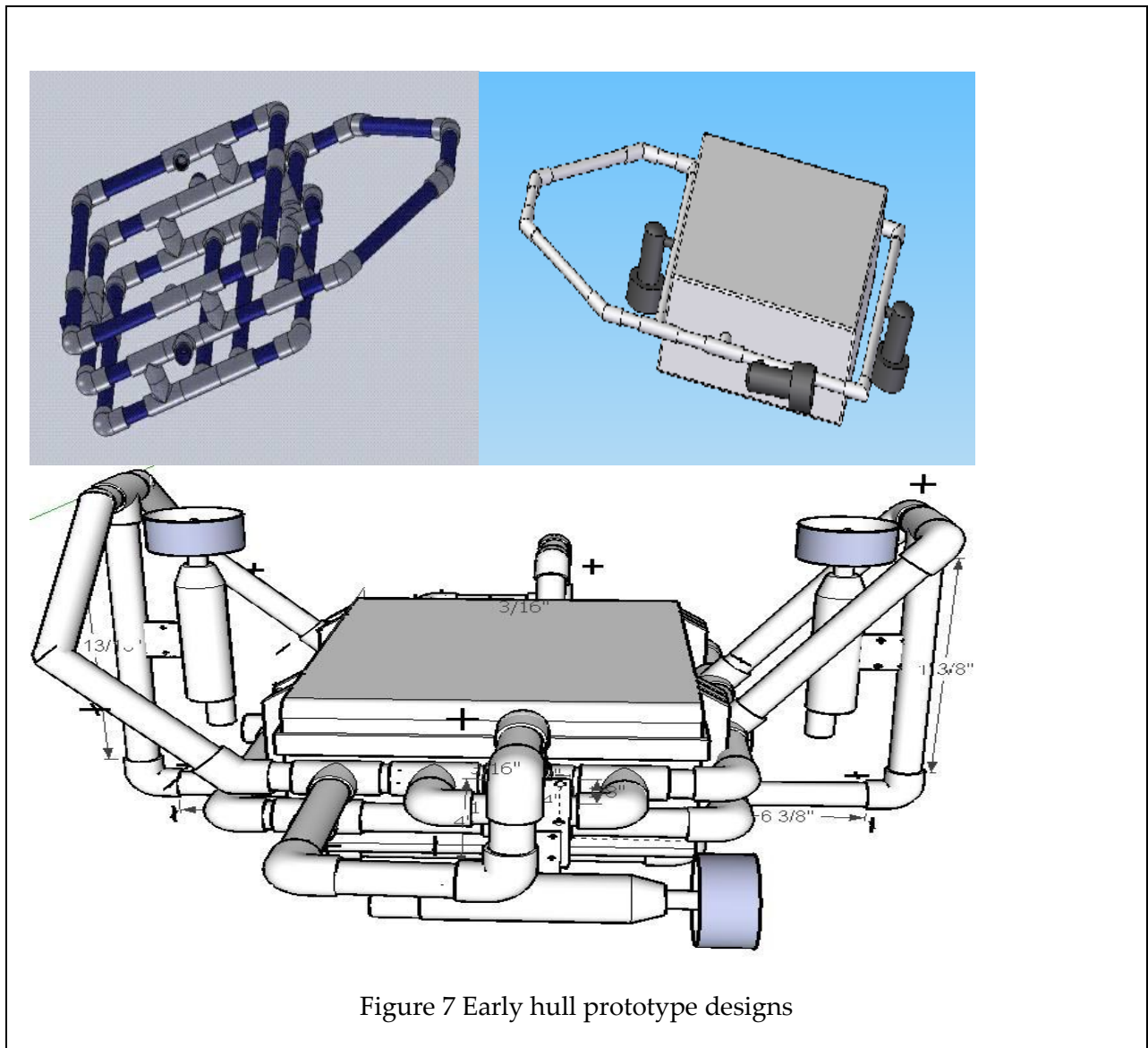

Figure 7 Early hull prototype designs

Although the Pelican box had many positive attributes like easy access, durability during machining through-hull connections, and a stable form in the water, the large volume of water displaced lead to a large buoyant force to overcome. Initial water tests done with free weights being added to the inside of the box yielded a positive buoyant force of over 350 N (80 pounds). Achieving neutral buoyancy was possible by adding weighted plates to the inside of the box that led to a robot that was almost 500 N out of water. A leaky O-ring was the last straw of this design and a complete hull redesign was sought.

The material chosen was PVC again for its ease of machining and availability. This time a section of 8"-PVC was used with an 8"-6" reducing T-bracket and end caps with screw in plugs. An exoskeleton made of angle iron and U-bolts provided a low center of mass to maintain proper orientation in the water and a platform for mounting the thrusters and mission specific mechanisms. This design, shown in Figure 9, was used in the demonstration at the regional competition at Gray's Reef.

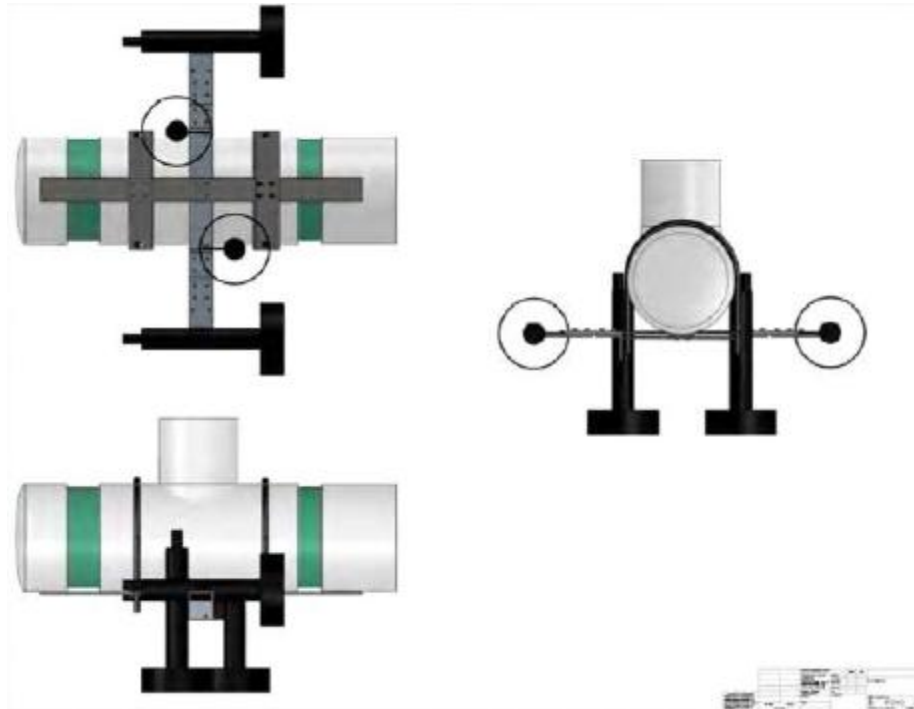

Figure 8 Design 2.0

While this design greatly reduced our overall size and weight and mainstreamed the entire vehicle, it had some major disadvantages as well. Even with the reduced volume, the overall buoyant force was positive and upwards of 175 N. Also, the through-hull connections were through one of the screw-in plugs of the end cap. This meant that when the vehicle was opened the entire tether, as well as some wiring inside, would twist as the cap was loosened or tightened. Also with the design being compacted, connecting wires and changing fuses while

the vehicle was assembled through the top cap was next to impossible. Although we achieved neutral buoyancy and all four required forms of motion to qualify for the international event, we had a leak through our top cap that caused the onboard electronics to short.

These issues and the addition of team members with metal machining knowledge led us to the aluminum hull that was custom fabricated for our specific needs. The main constraints are the onboard electronics. They were modeled in Solid Works and a hull was constructed around them as shown in Figure 10.

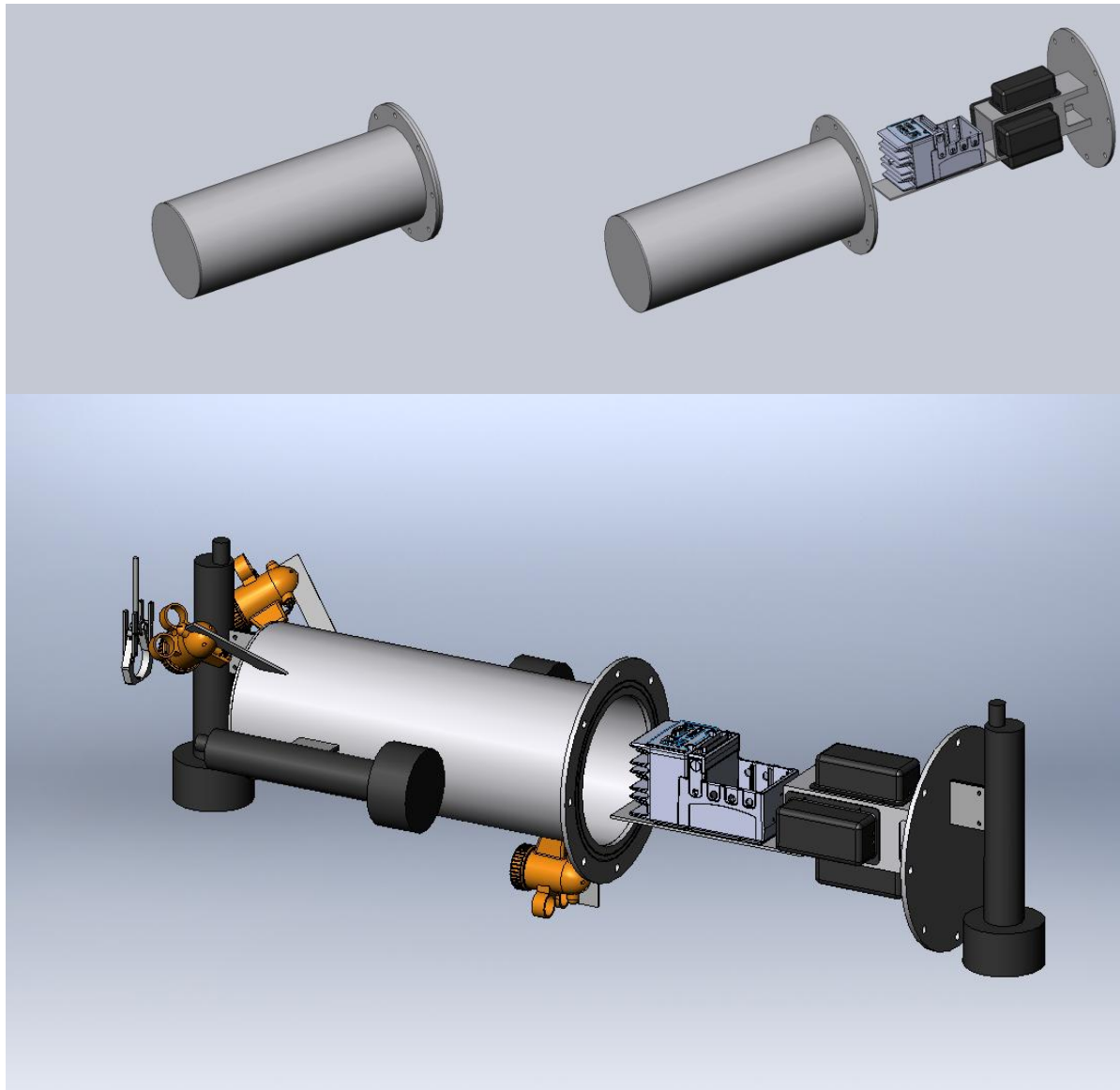

Figure 9 Metal designs in Solid Works

This design further reduced the volume of water displaced and therefore the positive buoyancy issue. Early calculations done in Solid Works actually yielded a slightly negatively

buoyant vehicle. Access to the vehicle is also much simpler with a flange containing a system of two o-rings and being held in place simply by nuts and bolts. All the electronics on the inside will be mounted on a single shelf which will be mounted to the back cap containing the through-hull connections. This allows for the areas sensitive to failure, hull penetrations, to be permanently put in place and reduce the loads on them that could cause leakage. Instead of bulky frames or exoskeletons, tabs can be spot welded around the vehicle for flexibility of thruster mounting and mission specific actuators.

Another PVC hull design is also being co-developed. This will yield two platforms for testing and a selection process can be applied to determine the best for certain applications. This will also allow for the team to grow in different directions and for full autonomy to be developed while maintaining our ROV roots.

## Thrusters

The ROV propulsion depends on 4 strategically mounted thrusters. Thrusters are small propulsive devices that control the ROV's speed, acceleration, and position in a three dimensional space. Thrusters also control different aspects of the ROV's performance such as hydrodynamics, drag, propulsion, and power. The basic components of a thruster are depicted in the figure below.

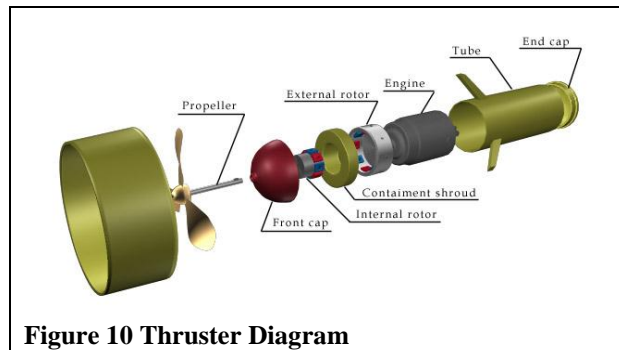

## CrustCrawler High Flow Thrusters

CrustCrawler's "High Flow" UROV thrusters were engineered to be rugged, customizable and provide maximum thrust in a compact, easy to integrate package. With the optional, programmable ETC, the throttle and brake curves can be customized to provide the programmable flexibility needed to set specific thrust parameters for different underwater conditions. Machined from top of the line materials, embedded with a gear reduced, powerful brushless motor and sealed with a custom engineered, replaceable fluoropolymer spring jacket seal with a life span of 6 – 7 million cycles, these thrusters provide outstanding maintenance free operation. For specifications see the appendix.

## Configuration

The ROV will be equipped with four thrusters which will allow range of motion in all three dimensions. The two horizontal thrusters provide forward and backward motion as well as angular torque on the ROV in a horizontal plane. This angular torque will make the ROV rotate on an axis by spinning one propeller clockwise and the other counterclockwise and vice versa. Two other thrusters will be placed vertically. These thrusters will provide upward and downward motions in a vertical plane. Moreover, the ROV will be able to move around its lateral axis (pitch) by spinning one vertical propeller clockwise and the other counterclockwise and vice versa.

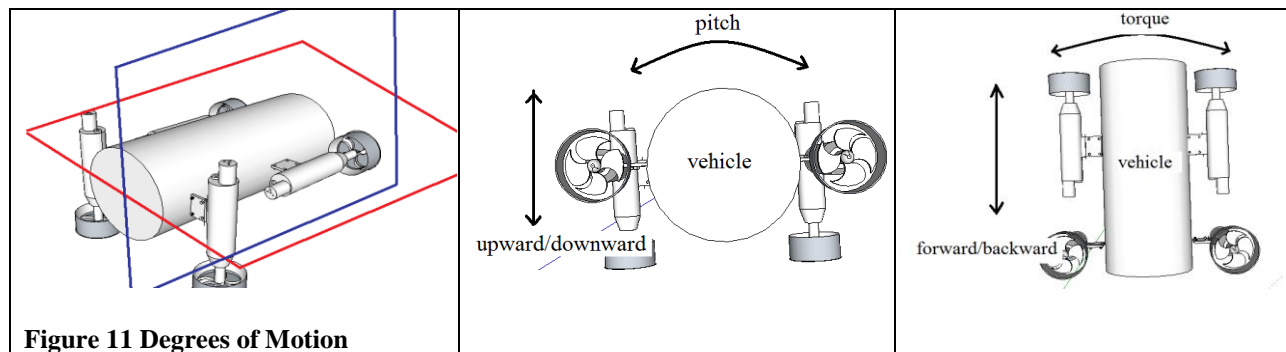

## Cameras

The cameras used on the ROV are *Navroute Tiburòns*. The *Navroute Tiburòn* is an inexpensive underwater camera, which can easily be connected to a RCA connector. This allows the operator to use a TV, VCR or even DVR to view or record underwater activity. The *Navroute Tiburòn* is packaged in high impact ABS (**Acrylonitrile butadiene styrene**) plastic, with 21 LED lights around the camera, placed inside the casing. The resolution of the camera is  $510 \times 492$ , and it is operated by an input voltage of 12V DC.



**Figure 12 Camera and adapter**

The EasyCAP USB 2.0 Video Adapter is used to connect the *Navroute Tiburòn* to the computer or laptop via USB. It can capture high-quality video and audio directly from a USB 2.0 interface. The solution for viewing multi camera on a computer was solved by the software VH Multi Camera Studio 1.1.0 available at <http://www.hmelyoff.com>. The VH Multi Camera Studio also offers video capturing software that can record video to a variety of formats.

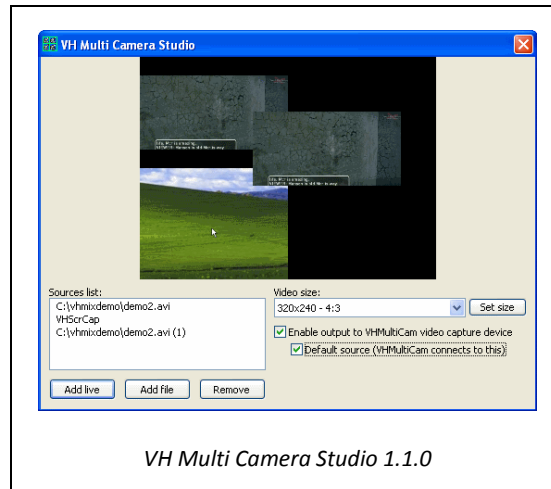

**Figure 13 Screenshot of camera interface**

## **Mission Specific Mechanisms**

Several methods of performing the missions were discussed and brainstormed over. An operating arm/claw was decided to be the best and a few options were modeled to be prototyped. We are currently in the testing phase of these designs and they will be presented in further detail in the engineering presentation and poster portion of the event. A basic outline of these is shown below.

**Mission 1:** Camera system around the vehicle to show all damage points

**Mission 2:** System of bilge pumps to operate hatch, claws to pick up ELSS pods

**Mission 3:** System of bilge pumps to open door, place ventilation tube in receptacle, and open valve

**Mission 4:** Skirt mounted on lower most point of the vehicle with complete camera coverage to show mating.

## Challenges Faced

The two main challenges faced throughout the process were the buoyancy issue of the vehicle and waterproofing the electronics. Neutral buoyancy is achieved when the weight of the vehicle is exactly equal to the weight of the water displaced by the vehicle while submerged. Our early problems stemmed from the vehicle having too much air trapped in dead spaces. This caused the vehicle to be positively buoyant. Early remedies for this were simply adding weight to the vehicle until it was neutrally buoyant. This led to an awkwardly heavy vehicle that was structurally unsound and ultimately leaked. The solution to this challenge was to simply reduce the volume of the vehicle to slightly larger than the size of our onboard electronics. This yielded buoyancy that was much closer to neutral and by adding weights or foam in certain areas neutral buoyancy could be achieved fairly easily. The issue of waterproofing was also resolved with the vehicle being machined with a system of o-rings on a grooved flange that are held under pressure by nuts and bolts.

Another challenge faced was the length of the tether vs. the transmission capabilities of the CompactRIO. The competition specifications for tether length are based on the total distance from the control shack to the sub in the pool. This is listed as approximately 16 meters. The transmission capabilities of the onboard computer were only 14 meters. This was rectified by adding a switch inside the vehicle to repeat and boost the Ethernet signal.

## Troubleshooting Methods

During the final water test before the regional competition, one of the thrusters was not working well. This was the first tube design in which we had the four thruster configuration of the two outer thrusters being for forward and backward, and horizontal turning (thrusters numbered 1 & 4), and two inner thrusters pointed vertically for depth control and roll (thrusters numbered 2&3), and all of which were mounted around the center of mass. Thruster 3 was not working. During the calibration process, a series of tones can be heard as the thruster cycles through all its ratings. This was heard but was very faint. In addition, after the tone the thruster was to start running and this was not happening at all. Since we heard the tone, we knew we were getting power to the thruster and since the other three were working fine, we deduced the computer controlling the PWM to the thrusters was not the culprit. That left the thruster controller (ESC), the fuse to the thruster, or a short in the wiring, or a faulty thruster altogether. To determine if the thruster itself was bad, we switched the lines coming from thruster 4 to the faulty one. Now thruster 3 worked fine and thruster 4 was doing the low tone and no motion behavior that thruster 3 was doing. We then determined that it was a fuse. We

opened the vehicle and changed the fuses (thruster 3 fuse was slightly discolored but not blown) and the same behavior continued. It was found later to be some Teflon paste used to seal the end caps had gotten into the ESC. This was cleaned up and all thrusters and ESC's have worked fine since.

## **Lessons Learned**

As a first year team in this competition, we have learned many valuable lessons. In addition to the technical aspects, we learned how to work as a team with many different personalities and across lines of study. For instance, we have grown to a group of about ten and we come from all different areas along the academic process. This means that some are very savvy to the technical aspects of hardware electronics and computer interfaces, while others are better with fluid mechanics, etc. Some excel in the computer drafting/CAD areas of design and some thrive in the lab area where the actual building of the prototype is their strong suit. This dynamic has turned us into a well rounded team for the competition as well as prepared us to work in similar environments for the rest of our academic and professional careers.

Time management was also a valuable skill developed during this process. Again, as a first year team, we had no prior designs to fall back on and we were fabricating as we went. This was not optimal because when issues came up along the way, we had to solve them by the quickest means available and that usually just led to more issues. Coordination of efforts and schedules turned out to be the ideal way of accomplishing things, rather than just everyone scrambling the week before the deadline and coming up with subpar solutions.

Another major lesson learned is when dealing with water and waterproofing, there is no margin for error. Even the smallest imperfection in sealing can be catastrophic, as we learned the hard way at the regional event, for onboard electronics. Precision manufactured components were the ultimate solution and this was still subject to some leakage if not properly tightened and operated.

## **Future Improvements**

The original goal of this project was for a fully autonomous vehicle. We plan to co-develop this as well as continue to improve our ROV building skills. Some future changes include: CMU cams to be able to run image processing software through the onboard computer and allow for self course correction and navigation, minimizing through-hull penetrations by incorporating thruster and sensor mounting directly into the hull, and improving the overall robustness of the design as to achieve neutral buoyancy and success during operations at increased depth.

## Submarine Rescue Organization Profile

The Submarine Parachute Assistance Group (SPAG) is an on call team of marine trained doctors and divers based out of the UK that respond to a catastrophic submarine accident/event. The general readiness of the team can be achieved in as little as six hours and can be dispatched anywhere in the world in less than 72 hours. The funding comes primarily from the International Submarine Escape and Rescue Liaison Office (ISMERLO) and direction of the team comes from the United Nations according to the ISMERLO website. Formed in 1967 by the Royal Navy according to the Royal Navy website, the SPAG team consists of members of the Submarine Escape Training Tank (SETT) staff. SETT is a 30-meter tower training facility that is located in the UK. It trains sailors from all over the world in the art of submarine rescue efforts and safety. The method most commonly taught there is the Buoyant Exhaling Ascent. This teaches submariners and rescue personnel how to ascend through depths of water without pressure related injuries. The swift action of this group is demonstrated in Figure 15.

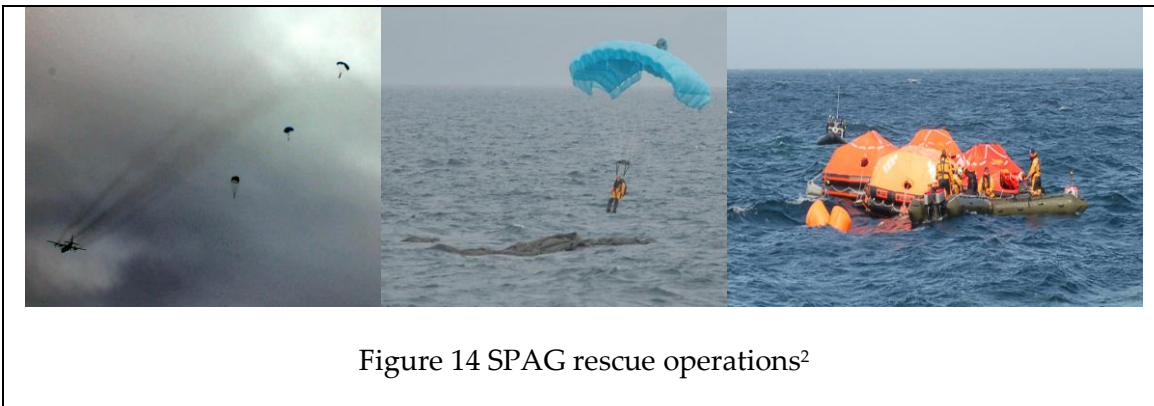

This organization currently does not make use of ROV technologies. They employ life boats, surface to air and surface to sub communications. They are capable of hot and cold rations and air delivery to the sub but are limited by depth. The technology that is being developed for this competition could be an invaluable addition to an organization like this in that they would have deeper access to sunken subs and would put less human life in danger by sending divers down to a disabled boats.

---

<sup>2</sup> Pictures courtesy of <http://www.subescapetraining.org/SPAG.html>

## Reflections

The major thing that I am taking away from this experience is to design thoroughly before building. I have always been a visual thinker and would build a little/design a little as I went. This led to many hours of building being wasted and the realization that a little thought and design prior to building will not only save time but yield a much more robust end product.

Steven T Bradshaw (ME/EE undergrad)

As a software designer, I learned that software is never 'complete' but always a work in progress. Constant re-evaluation of your user's needs to improve the interface is important and ongoing. Additionally, code optimization became an important part of this project as it reduced lag time between thrusters engaging.

Brandon R Groff (CmpE undergrad)

The CompactRio, which controls the motion of the ROV in a 3D space, is one of the most important elements of this project. I learned that it is important to know in detail all the features and characteristics of the hardware. By doing this it becomes easier to fix problems and incorrect setups of the host computer and the CompactRio when malfunctions occur.

Angel Berrocal (EE undergrad)

Through the use of Solidworks, I took away a new appreciation for the implementation of 3D modeling using mechanical design in a research environment. Solidworks allowed me to learn the importance of 3D modeling in streamlining and increasing efficiency of a proposed design. I have gained a new understanding of the importance of intelligent design in real world applications.

Spencer Burch (ME undergrad)

I joined the team with experience building competition, land based robots. As a part of this team, I'm no longer working on my own or leading inexperienced students. Now, I'm learning from more experienced students. My biggest challenge has been to adapt my knowledge to underwater robots. I see this as a great opportunity for me to gain even more knowledge and experience.

Matt Carroll (ME undergrad)

In building the robot, I've encountered a world of application closed off from the classroom setting. The amount of knowledge that I have gained in the few weeks that I have been included in this redesign of the ROV is immeasurable. The most important lesson that I've

taken from this experience, thus far, is to expect, for every design, an innumerable amount of changes to that design.

Jasmine Magerkurth (ME Undergrad)

Prior to joining the team, I had no previous knowledge of robotics. During my time working with the team, I learned how much goes in to building an ROV, which opens my mind for how robots can be built. One of the major aspects that I learned is the amount of detail that is put into every part such as the design, computer programming and the hardware aspects incorporated into the completed vehicle.

Rich Nguyen (CompE undergrad)

## References

Royal Navy Website:

[http://www.royalnavy.mod.uk/operations-and-support/establishments/naval-bases-and-air-stations/hmnb-portsmouth/submarine-escape-training-tank/submarine-parachute-assistance-group-\(spag\)/](http://www.royalnavy.mod.uk/operations-and-support/establishments/naval-bases-and-air-stations/hmnb-portsmouth/submarine-escape-training-tank/submarine-parachute-assistance-group-(spag)/)

ISMERLO Website:

<http://www.ismerlo.org/>

3D Mouse Pictures:

<https://3dconnexionstore.com>

Camera Data:

<http://www.hmelyoff.com/index.php?section=33>

<http://navroute.com/nauncasyti.html>

## Acknowledgements

Georgia Institute of Technology- Savannah

Dr. Fumin Zhang

Dr. David Frost

Solid Works

Ferguson Enterprises Incorporated

National Instruments

## Appendices

### Budget/Expense Report:

The majority of the funding for this project comes from a research grant given to Dr Fumin Zhang et al. This was to develop exploratory underwater and amphibious autonomous and remotely operated vehicles. A large portion of the travel expenses and other funding were from Georgia Institute of Technology-Savannah's Director of Student Affairs, Dr. Robert Frost. The expense report is shown in Figure 1 reflects all contributions and donations. At this time, no donations were given by an outside company.

<i>Contact Justin Shapiro (shapiro@gatech.edu) for any additional information</i>				
Distributor/QTY	NAME	Comment/PN		
<b>Buy.com</b>				
1	8 GB micro SD Digital camera storage		12.82	12.82
1	Olympus Stylus 1050 SW Digital Camera		164.95	164.95
<b>Crust Crawler</b>				
5	ESCx5 Thrust Controller		299	1495
1	ESC Programming cable		23	23
4	Crustcrawler High-Flow Thruster		1400	5600
4	ESC for High-Flow Thruster		300	1200
1	ESC Programming cable		23	23
<b>Jamestown Distributors</b>				
5	JPI-32903 950 GPH 3/4" HOSE 24/CS	Bilge Pumps	40.32	201.6
<b>3d Connection online</b>				
1	3D Mouse	Explorer	299	299
<b>McMaster Carr</b>				
2	clear PVC 6"X4'	49035K35	185.87	371.74
2	6" reduced to 4"	4881K138	67.69	135.38
4	6" U-Bolt	3176T43	29.98	119.92
2	6" Round Cap, Sch 80	4881K522	41.94	83.88
8	8-3/4" U-bolt	McMaster Carr	7.3	58.4
<b>National Instruments</b>				
1	NI cRIO-9022	780718-01	3,199.00	3199
1	NI cRIO-9113	780917-01	1,999.00	1999
1	PS-1 120VAC Input	777567-01	79	79
1	NI 9978	196938-01	19	19

1	NI 9938	192665-01	29	29
1	NI 9403 with DSub	779787-01	349	349
1	NI 9933 37pin D-Sub connector kit	779103-01	149	149
1	NI 9870 with (4) 10P10C to DE9 Cables	779891-01	579	579
<b>Digikey</b>				
2	CONN PLUG RJ45 FREE HANGING IP68	708-1002-ND	16	32
2	CONN RCPT 8-8 PNL MNT IP68	708-1009-ND	33	66
2	BACKSHELL SHIELD USE W/PX0833	708-1373-ND	1.67	3.34
2	CONN CAP SEALING FOR W/ALL OTHER	708-1180-ND	1.14	2.28
2	CONN PLUG 2POS W/PINS	708-1184-ND	19.14	38.28
2	CONN JAM NUT 2POS W/SOCKETS	708-1209-ND	13.65	27.3
2	SEALING CAP W/PX0911 AND PXA911	708-1225-ND	3.02	6.04
2	SEALING CAP FOR PX0931 & PX0941	708-1388-ND	15.69	31.38
<b>Ferguson Enterprises INC.</b>				
1	6" FEM CO ADPT		13.5	13.5
1	16 oz. Purple Primer		6.7	6.7
1	32 oz. PVC CEMENT		8.1	8.1
1	PVC-T 8"X6"X8"		32.1	32.1
<b>Seattle Robotics</b>				
3	CMUcam3		239	717
<b>BK-Precision</b>				
1	Programmable DC Power Supply		629	629

## Compact Rio and Thruster Specifications

### Compact RIO

-40 to 70 °C (-40 to 158 °F) operating temperature

Up to 2,300 Vrms isolation (withstand)

50 g shock rating

Dual 9 to 35 VDC supply inputs, low power consumption (7 to 10 W typical)

Dimensions (Four-slot) 179.6 by 88.1 by 88.1 mm (7.07 by 3.47 by 3.47 in.)

Weigh 1.58 kg (3.47 lb)

### Thrusters

Motor Type	High efficiency brushless
Weight	274g. (9.7oz)
Max Power	600W
Max Motor RPM	40,000 RPM
Gear Ratio	4.28:1
Shaft Diameter	5.0mm(.1969")
Maximum Case Temperature	100C (212F)
Operating Voltage	6 to 25 volts
Depth Rating	2,000 ft.
Seal type	Rubber o-ring
Thruster Housing / End Caps	T- 6 Aluminum
Thruster Seal	Custom fluoroloy spring jacket seal with multistage o-ring
Finish	Type III Hard Anodized Finish
Propeller	Size - 3.4" - 4 blade Material – Solid Brass Propeller Adapter – Stainless steel Efficiency Range – 1,500 – 3,000 RPM
Thrust Rating	16 pounds + (7.27kg)

**Table 2 Thruster Data**