

LONG BEACH CITY COLLEGE VIKING EXPLORERS  
Long Beach, California  
*EXPLORER CLASS*



# ROV VIKING SPEAR

**S**UBMARINE **P**ERSONNEL **E**MERGENCY **A**SSISTANCE **R**OV

## Technical Report

8th Annual MATE International ROV Competition  
The Next Generation of Submarine Rescue Vehicles

### TEAM

Ian Jasper, Team Captain	Electrical Technology	May 2009
Ricardo Casaine	Electrical Technology	August 2009
Stuart Cook	Electrical Technology	May 2010
Nathan Grefe	CSULB Transfer	May 2009
Baxter Hutchinson	Electrical Technology	May 2010
Adam Ramsey	Electrical Technology	May 2009
Ferruh Unlu	Programming	in the future
Andy Walsh	Electrical Technology	May 2009
Harleigh Williams	Engineering	May 2011
Scott Fraser	Instructor	

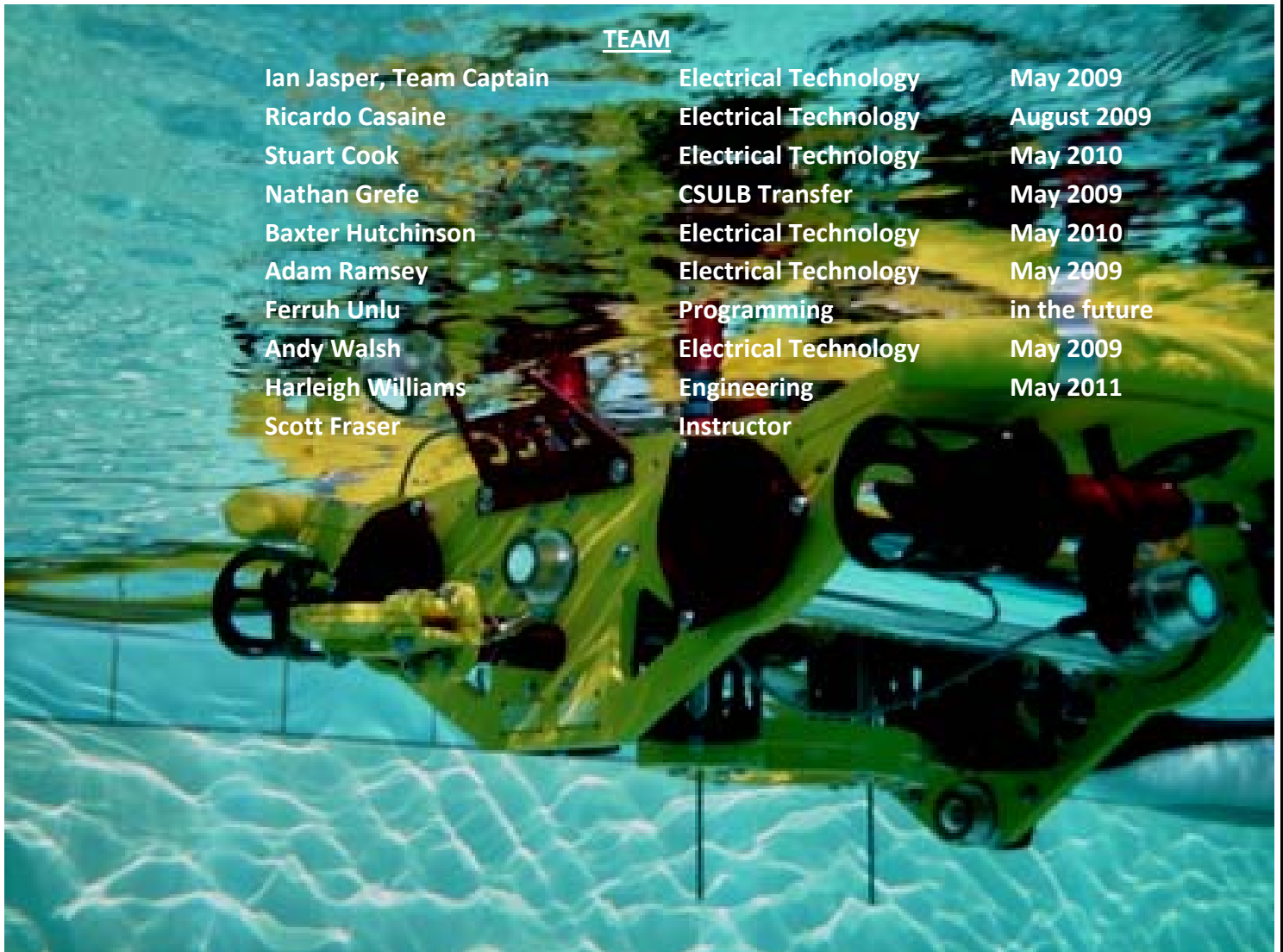

FIGURE 1 – COMPLETE PHOTO OF INTACT ROV IN ACTION

## ABSTRACT

Long Beach City College returns for our sixth year to enter the 2009 MATE Remotely Operated Vehicle (ROV) competition with our latest ROV, the Viking SPEAR (Submarine Personnel Emergency Assistance ROV). The purpose of this ROV is to perform an underwater submarine rescue by inspecting it for damage, replenishing onboard air supplies, and delivering emergency materials to stranded crew members. This year's ROV, designed in SolidWorks, is cut out of buoyant PVC, has a mass of 21kg and is built to allow maximum water flow. The ROV is 38cm high x 87cm wide and 95cm long. The major design focus was on redundancy and design functionality. The ROV has two, multi-functional pneumatic grippers, one at each end of the ROV, eight thrusters, and eight cameras covering all angles of viewing. A mating skirt is built into the existing frame design for easy docking on the submarine. These features allow the pilot to execute the several tasks set forth by MATE in a timely fashion while providing the redundancy needed for a submarine rescue mission. In accomplishing the design and build of this ROV, the team created over 250 SolidWorks files, invested over 5000 student hours, and corresponded daily utilizing the team's online design forum. The entire project was heavily invested in Computer Aided Design and Manufacturing (CAD/CAM). The only system not designed by this team was the Fiber-Optic Video Link.

## Table of Contents

ABSTRACT.....	1
DESIGN RATIONALE - TASKS.....	2
TASK #1 – Damage Survey .....	2
TASK #2 – Pod Posting .....	2
TASK #3 –Ventilation .....	3
TASK #4 – RORV Mating.....	3
DESIGN RATIONALE – ROV COMPONENTS.....	4
ROV FRAME.....	4
ELECTRONICS HOUSINGS .....	5
THRUSTERS .....	6
TETHER.....	6
CAMERAS .....	7
SURFACE ELECTRICAL SCHEMATIC .....	8
SURFACE CONTROLS.....	9
ELECTRONICS .....	9
ROV WIRING SCHEMATIC.....	10
SOFTWARE .....	11
TROUBLESHOOTING TECHNIQUES .....	13
Submarine Rescue and the U.S. NAVY .....	14
CHALLENGES .....	15
LESSON LEARNED .....	15
FUTURE IMPROVEMENTS.....	16
ADDITIONAL TEAM PHOTOS .....	16
REFLECTIONS ON THE EXPERIENCE .....	17
BUDGET/EXPENSE SHEET .....	18
REFERENCE SOURCES .....	19
ACKNOWLEDGEMENTS .....	20

## DESIGN RATIONALE - TASKS

With the MATE ROV Competition focusing this year on submarine rescue systems, the team decided that it would be important to stress both reliability and redundancy throughout the design, construction, and testing of our ROV.

### TASK #1 – DAMAGE SURVEY

The first mission that the ROV will have to perform requires that it be piloted around the circumference of the simulated submarine to identify damage spots marked with number plates. The ROV employs eight cameras, affording the operator excellent color images in all directions, with directly vertical up being the only exception. Side facing cameras are dedicated to the damage survey task. This allows the pilot to maintain a forward driven path while searching for damage in the second monitor.



FIGURE 2 – SPEAR OPENING AIRVALVE ACCESS HATCH FOR TASK #3

### TASK #2 – POD POSTING

The pneumatic gripper used for pod-posting is designed to use the front gripper jaws to obtain the ELSS pods, as well as opening the conning tower door to access the air resupply valve. The five pods are to be retrieved by the ROV from the carousel assembly and transferred to the emergency hatch; the rear gripper of the ROV can be used as a backup if needed. After the hatch has been opened, the five pods are set inside the emergency hatch area. A Hatch Spanner mechanism was integrated into the ROV frame to allow the vehicle to turn the hatch wheel. Operating the hatch is accomplished by setting the ROV on top of the hatch and rotating the entire vehicle. A top down camera is mounted above the mechanism to help line up the ROV for this task. A bottom camera insures engagement. The two cameras used for this task are also used for the RORV Mating Task.

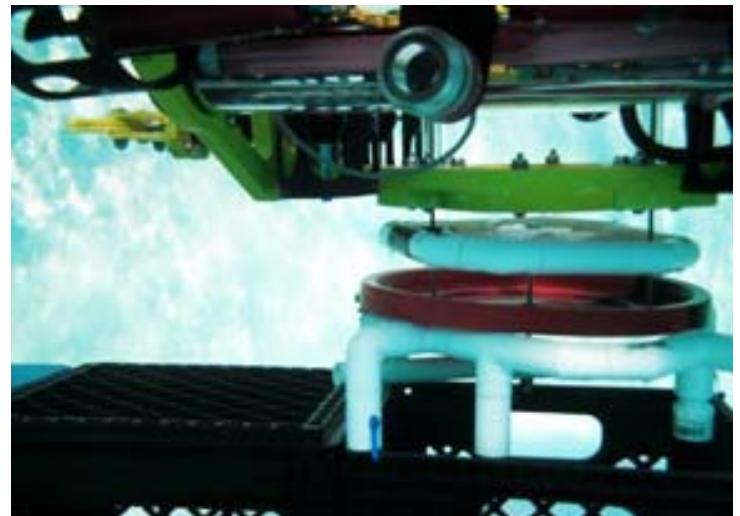

FIGURE 3 – HATCH SPANNER ENGAGED ON THE EMERGENCY RESUPPLY HATCH FOR TASK #2

### TASK #3 – VENTILATION

The Ventilation task requires that a simulated airline must be brought from the surface, an access hatch opened, the airline nozzle inserted into the inlet valve connection and then the air valve opened. After 10 seconds, the process is reversed.

Crucial to the successful completion of this task is the ROV's second pneumatic gripper, designed specifically for this task, though it is also capable of picking up the ELSS pods and opening the hatch on the conning tower. The gripper is made out of a single piece of sheet metal with two curved hooks on the outside with another piece bent at a 45° degree angle forming a trident shape. The only moving piece besides the cylinder rod is the finger on the top of the gripper that holds the airline nozzle firmly in place. Fewer moving parts reduce the likelihood of gripper malfunction. The inside of the hooks on the gripper are painted bright yellow to add some depth perception. The gripper is a vital part of the ROV, which has received continual design revision by the team. Both of the grippers are designed to be another redundant system, so if one of them were to malfunction, the ROV would still be able to complete its assigned tasks.

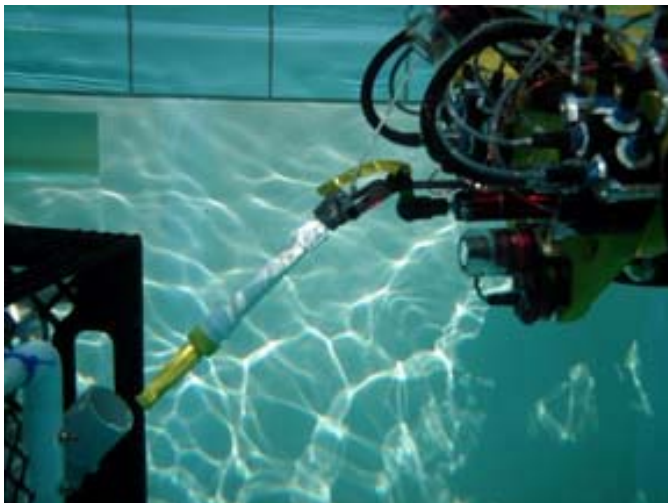

FIGURE 4 – SPEAR INSERTING AIRLINE NOZZLE FOR TASK #3

### TASK #4 – RORV MATING

The Remotely Operated Rescue Vehicle (RORV) mating task involves docking the integrated mating skirt of the ROV with the simulated escape hatch of the submarine. On a full-sized ROV, the purpose of the skirt would allow the transfer of personnel from the damaged sub into the ROV. In keeping with the spirit of the task, we have been careful to integrate the mating skirt onto the frame of the ROV, which we believe better represents the operational intent of the device. Our design locates the skirt centrally at the bottom of the ROV, best enabling the pilot to maneuver into place over the simulated escape hatch. To aid in this task, two dedicated cameras give exceptional views of the task theatre.

One camera mounted atop the ROV looks directly down through the center of the mating skirt. The second camera not only provides an “approach” view, but also serves to provide an excellent perpendicular side view to verify that the entire hatch has been covered, meeting the requirements for the task.



FIGURE 5 – BOTTOM VIEW OF ROV SHOWING INTEGRATED MATING SKIRT AND DUAL CAMERAS FOR TASK #4. THE HATCH SPANNERS FOR TASK #2 ARE ALSO SHOWN

## DESIGN RATIONALE – ROV COMPONENTS

Among the tools the team utilized to achieve its' goal was an extreme emphasis on highly detailed design using the computer aided design (CAD) software SolidWorks. This was coupled with a desire to manufacture every possible component within our capabilities either in the electronics lab or machine shop at school. Another invaluable asset was the use of a CNC router that the team used to manufacture the majority of plastic and aluminum components on the ROV.

### ROV FRAME

A crucial decision was made at the beginning of the design process to use a commercially available form of low density PVC plastic. The plastic had a density of  $0.55\text{g/cm}^3$ , which compared to that of fresh water at  $1.0\text{g/cm}^3$  gave it quite a bit of buoyancy. As the dimensions of the electronics tubes and thrusters slowly began to emerge during the design process, work on the frame began to accelerate. A shape that the two electronics tubes would slide through with a forward and rear bulkhead was decided upon. These two bulkheads would be the true core of the machine allowing for the mounting of the grippers and vertical thrusters. The frame would then have two structural members at the top and bottom running down the center of the structure to provide rigidity and a mounting surface for some of the vehicle's hardware. Lastly, a set of "wings" as the team has affectionately deemed them were added to the upper portion of the frame to provide a high center of buoyancy and a surface to mount the horizontal thrusters. All of these pieces were then fitted

together using an interlocking joint pattern to reduce the number of fasteners required to hold the whole assembly together. This technique quickly earned the frame the nickname of "IKEA bot" after the furniture store, which uses a similar "knock-down" design in their products. After this basic concept had been envisioned and drafted in SolidWorks 3D design software, the heavy work began. Once the frame was fully designed, the team cut the frame out in one afternoon using our CNC router.

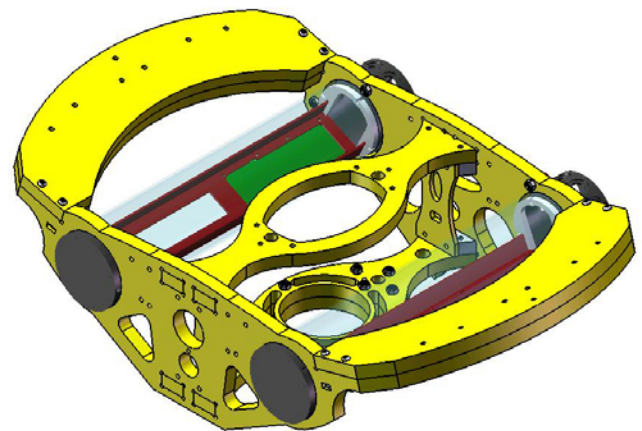

FIGURE 6 – SOLIDWORKS INITIAL FRAME LAYOUT



FIGURE 7 – ANDY WITH THE TETHER IS READY TO RESCUE

## ELECTRONICS HOUSINGS

Early on in the design process it was decided a dual pressure housing system was to encapsulate the circuit boards on the ROV. The idea behind using two electronics housings was to minimize the amount of space taken up by electronics on the ROV by spreading out the circuitry over two pressure tubes. This allowed for a much easier system of weight distribution across the vehicle and provided additional redundancy. The team reasoned that the utmost goal in any submarine rescue mission is the preservation of human life even at the cost of damage to the ROV itself. By building a redundant control system in each tube, the ROV was now capable of losing function of an entire electronics assembly but still able to maintain enough functionality to complete the mission. This capability would be able to save valuable time that would be required to repair another system. That time saved could very well be the difference between a rescue mission and a recovery mission for the ROV. The last desired function of the electronics tubes was that they be easily accessible for maintenance and modification.

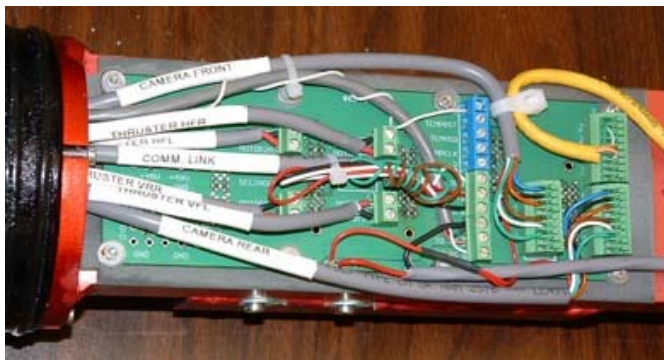

FIGURE 8 – BOTTOM SIDE OF CONTROLS SHOWING WIRING

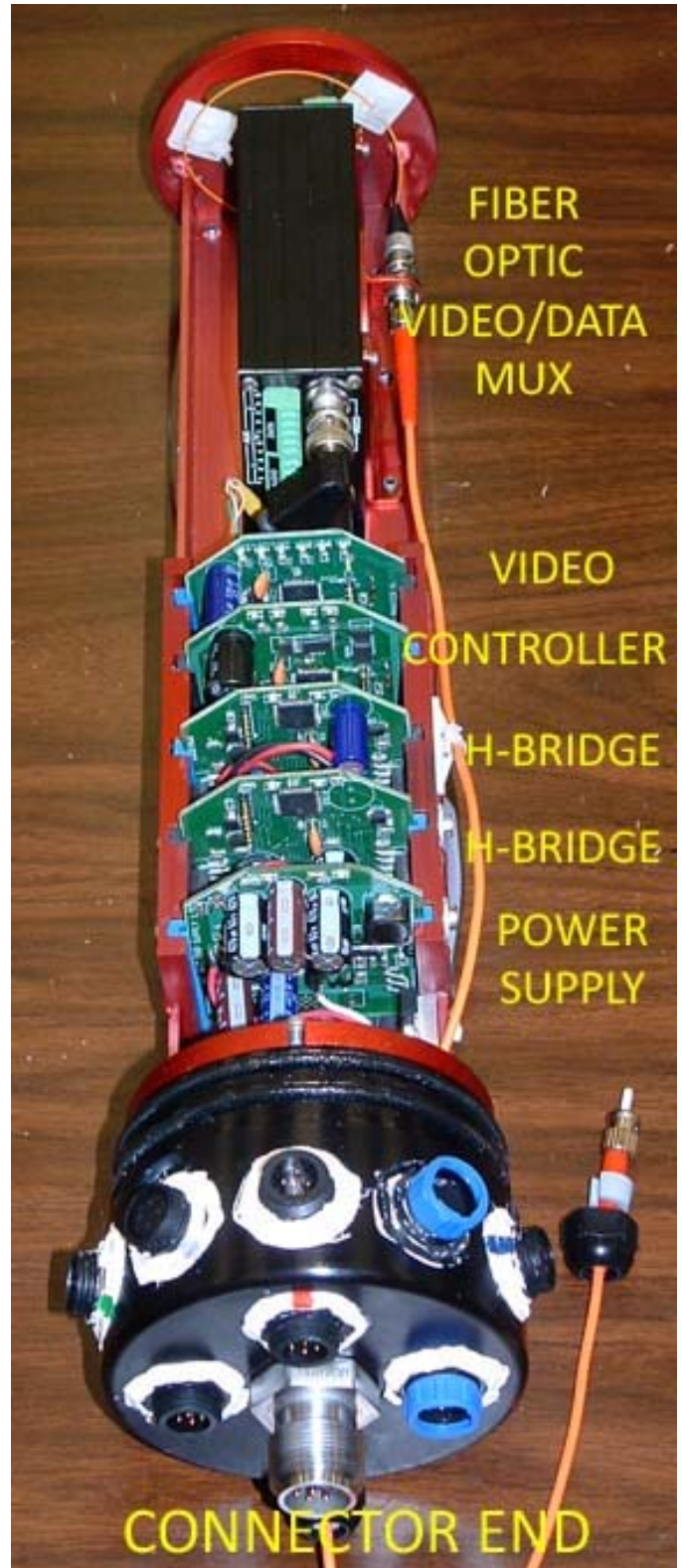

FIGURE 9 – TOP VIEW OF ELECTRONICS CONTROL HOUSING WITH ACRYLIC TUBE REMOVED

## THRUSTERS

In the beginning of the year, the team set a personal goal of designing their own thruster assembly. Our plan was to build our own thrusters that would be comparable in performance to those commercially available. A compact housing would also be needed to cut down on drag considering that we planned on using eight of them. Each thruster is composed of a 150 Watt motor, an aluminum housing, a shaft coupling, a propeller shaft, and two caps on each end to seal the tube.

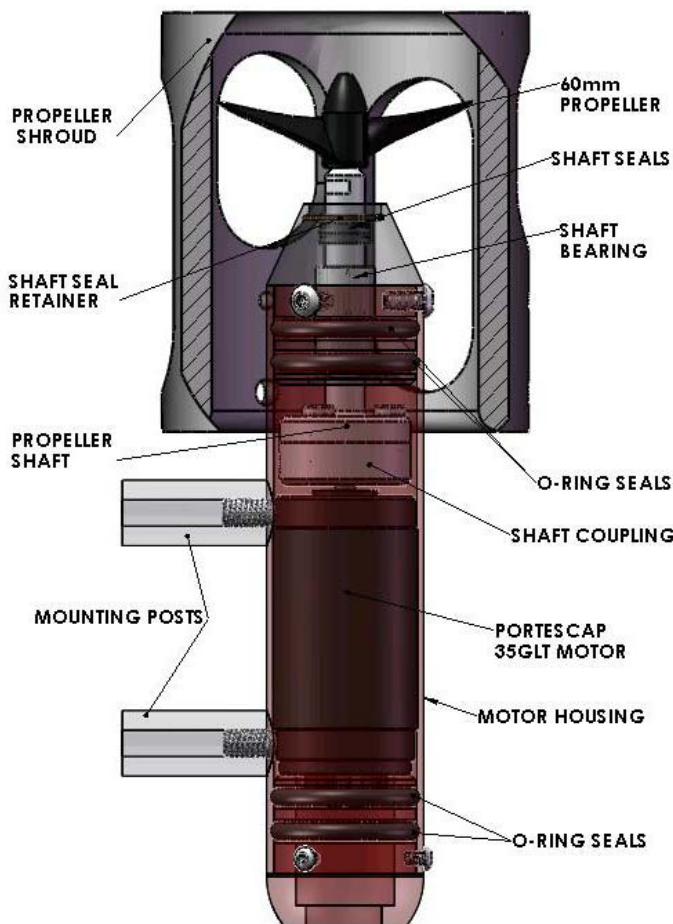

FIGURE 10 – SOLIDWORKS CUTAWAY VIEW OF THRUSTER

The motors we decided to use were Portescap's 35GLT motors due to their small size and high power output. The fact that the motors would run on 48 volts also simplified design by matching the motor voltage to the supply voltage. These motors were then matched with a housing made of thin wall aluminum tubing that was reamed out to provide an interference fit for the motors. By having the motors tightly pressed into the aluminum tube, a perfect heat transfer connection was made from the motor to the housing to the outside water. The thrusters tested generating 3kg of thrust in the forward direction and 2.2kg in reverse. The thruster housing was also pressure tested in water to a depth of 20 meters for 15 minutes without leaks.

## TETHER

The Tether is the lifeline of the ROV, supplying power, communication and air. It is composed of a multi-conductor power cable, two fiber optic lines, and four airlines. Power is supplied to the ROV through a neutrally buoyant cable. The large number of small conductors allows the tether to be flexible and provide the required amount of conductor area to minimize voltage drop. A neutrally buoyant cable was chosen so that the cable will not affect the buoyancy of the ROV while under operation. Dual fiber optic lines are used to run video and communication between the ROV and the surface control computer. Using two fiber lines, we ensure redundancy in case one line is damaged. The airlines we chose to control the grippers are color coded for quick connection. We use two airlines for supply of air, and two are used for exhaust. In order to keep the whole bundle in one neat package, we used a yellow nylon sheathing that stretches down the entire length of the tether. The entire tether bundle was wrapped onto a hose reel that was attached to a backpack frame. This made the tether easy to handle and quick to deploy. See Figure 7 for a photo of the tether and backpack.

## CAMERAS

It is important that the ROV pilot be provided with good visual data to base decisions upon. This is why good clarity and multiple views of a situation are so important on a ROV. Along with redundancy, this was the driving concept behind our camera design. We decided that a modular and compact camera design would be the best approach. After the team had designed the relatively simple cameras, the matter of their layout led to the development of some very interesting techniques.

Inside the computer design program SolidWorks, the team discovered a function that allowed the simulation of camera views. With this function, the team was able to modify the simulation to account for the distortion of the camera view caused by being in water. Once this was complete, we were able to shift the locations of the cameras on the vehicle to create highly functional views of all the tooling packages for the ROV's pilot.

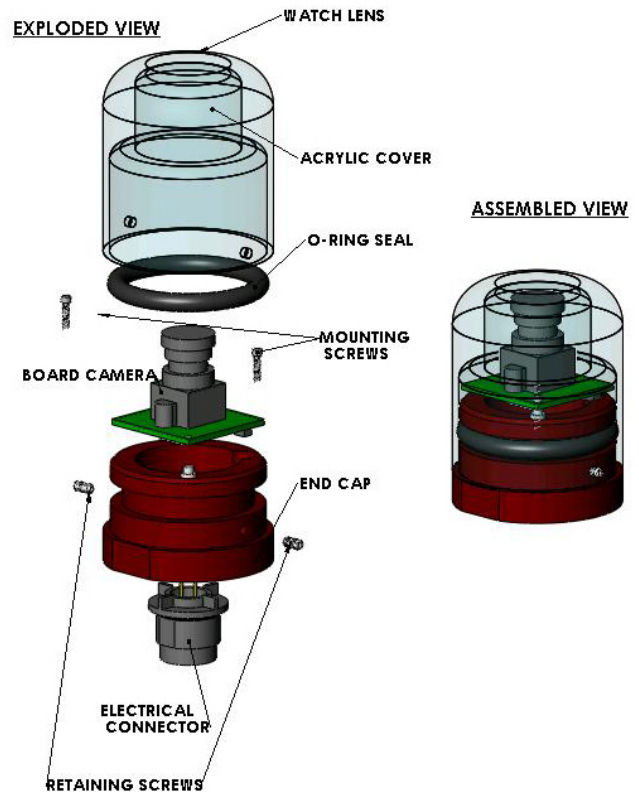

FIGURE 12 – SOLIDWORKS EXPLODED VIEW OF CAMERA ASSEMBLY

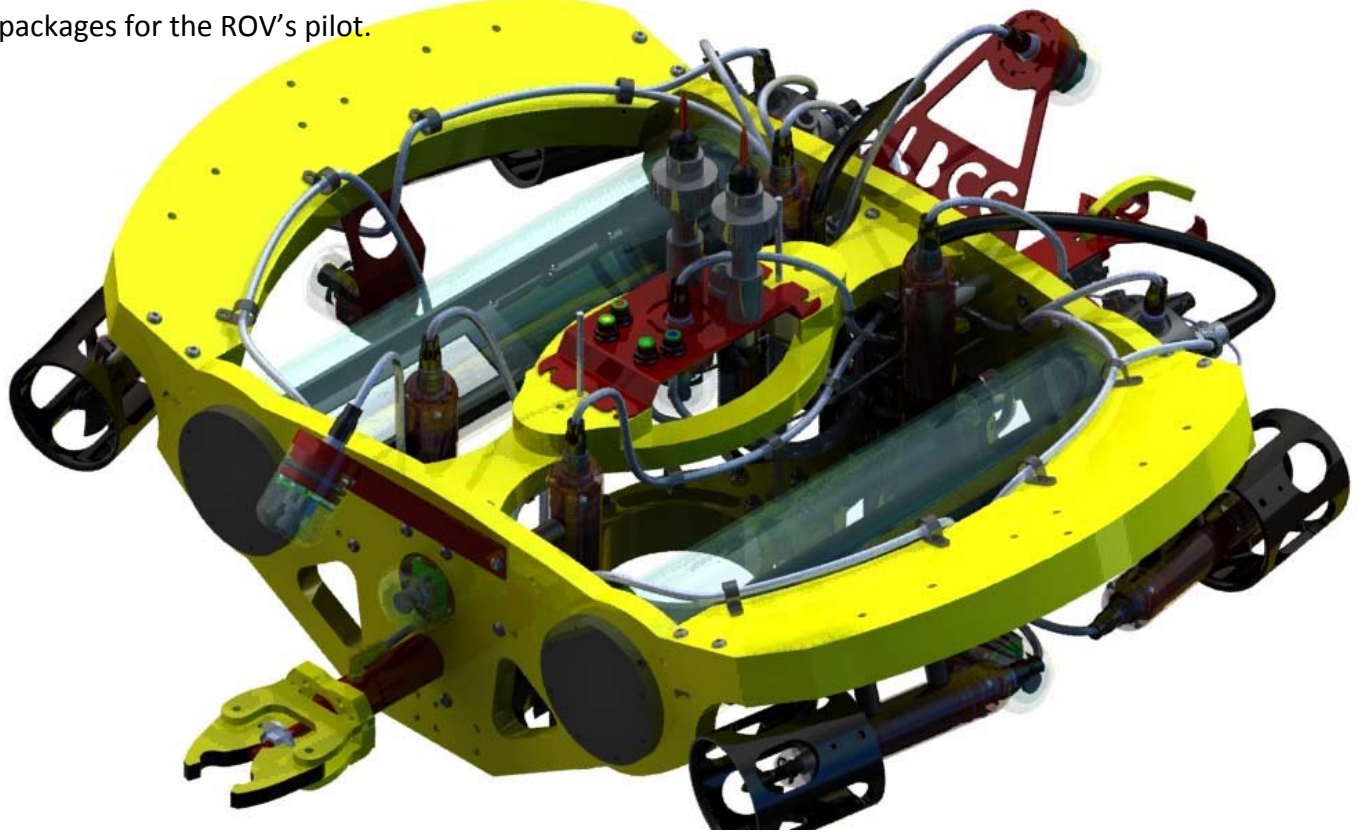
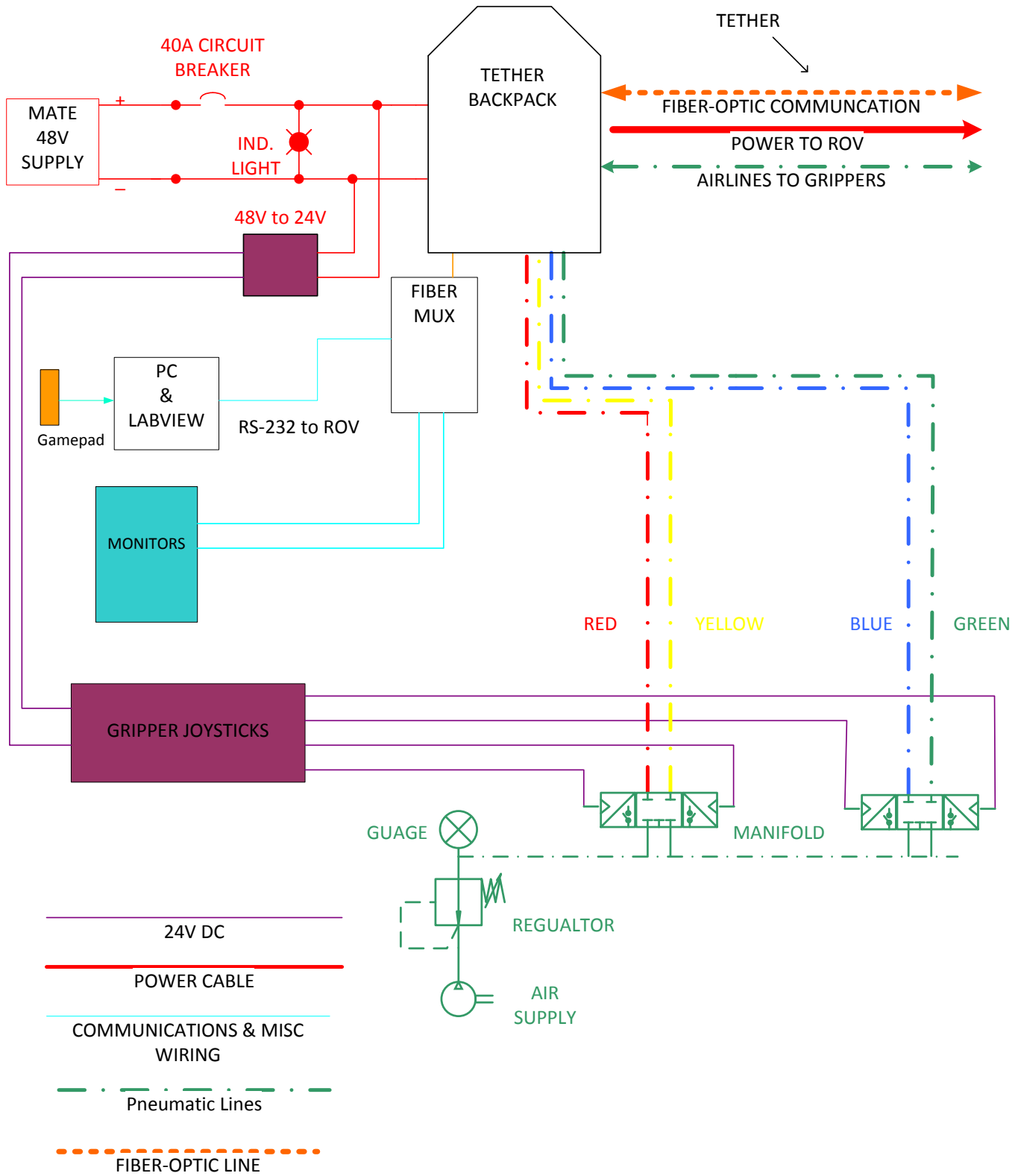

FIGURE 11 – SOLIDWORKS PHOTO RENDERING OF ENTIRE ROV

SURFACE ELECTRICAL SCHEMATIC



## SURFACE CONTROLS

This year's design specs required all systems to be carried down a flight of stairs. Because portability was a major factor, we started the design process with these objectives in mind: to be small, portable and have a durable platform. We chose a 'Stormcase' to house all the surface controls. The case is large enough to contain the controls, three LCD screens, and the control computer. The control box contains an Air Regulator, an Air Manifold, (2) Arcade Joysticks, 120V power-in circuit breaker, 120V to 12V power supply for the monitors, 48V 40A circuit breaker, Indicator light, 48V to 24V transistor and Fiber-Optic Video/Data Multiplexer.

The control box was designed with simplicity in mind; we wanted all of the systems to be easily accessible. We mounted all inputs on the right side of the case and all outputs to the tether on the left side. These placements insured simple routing of all wires. By installing a Lexan window in the control box, we can visually verify the operation of the ROV/control link. We are also able to see that the airline regulator is properly set to 40 PSI.

## ELECTRONICS

The electronic circuitry that composes the heart of the ROV is divided between two different electronics housings. Each housing contains a mother board that all of the other circuit boards for that tube. Each tube houses a power supply card, two H-bridge cards, and a controller card. One tube holds the LED control card and the other the Video Switch Card and the fiber optic multiplexer. One of the controller cards is running the entire ROV while the other serves as a backup. Each H-Bridge card drives two thrusters using pulse width modulation (PWM) and an H-Bridge circuit.

This allows for control of the speed and direction in which each of the thrusters provide propulsion. The power supply card creates 12 and 5 volt supplies to run the other systems from the 48V input. The video switching card takes the eight video signals from the cameras onboard the vehicle and switches to the two signals that the operator desires. These two video signals are then sent to the fiber optic multiplexer and then to the two monitors on the surface.

All of these circuit cards were built, soldered, tested and programmed by the team. Design of the H-Bridge and controller cards was done in class as part of the course with help from our instructor. Students then designed the entire circuit board for the LED driver and the Video Switch.

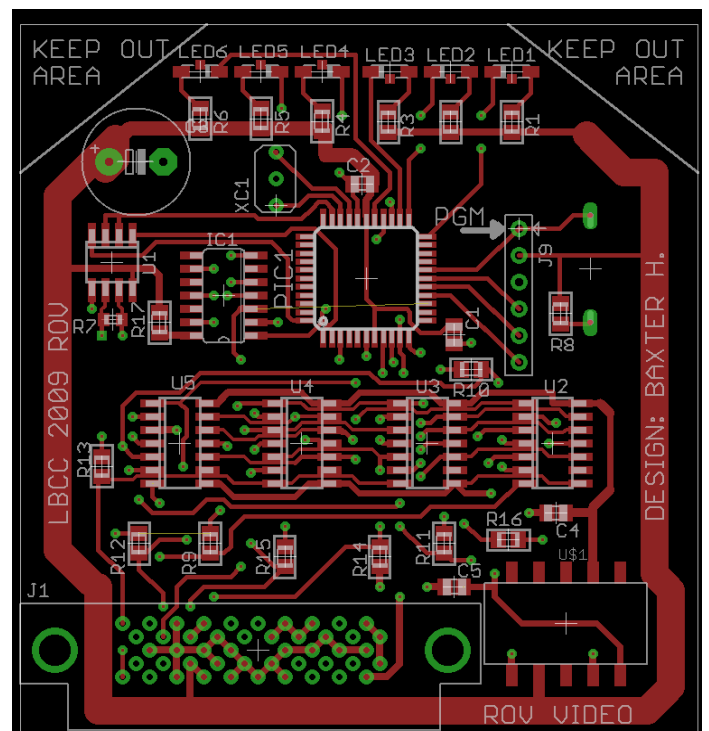
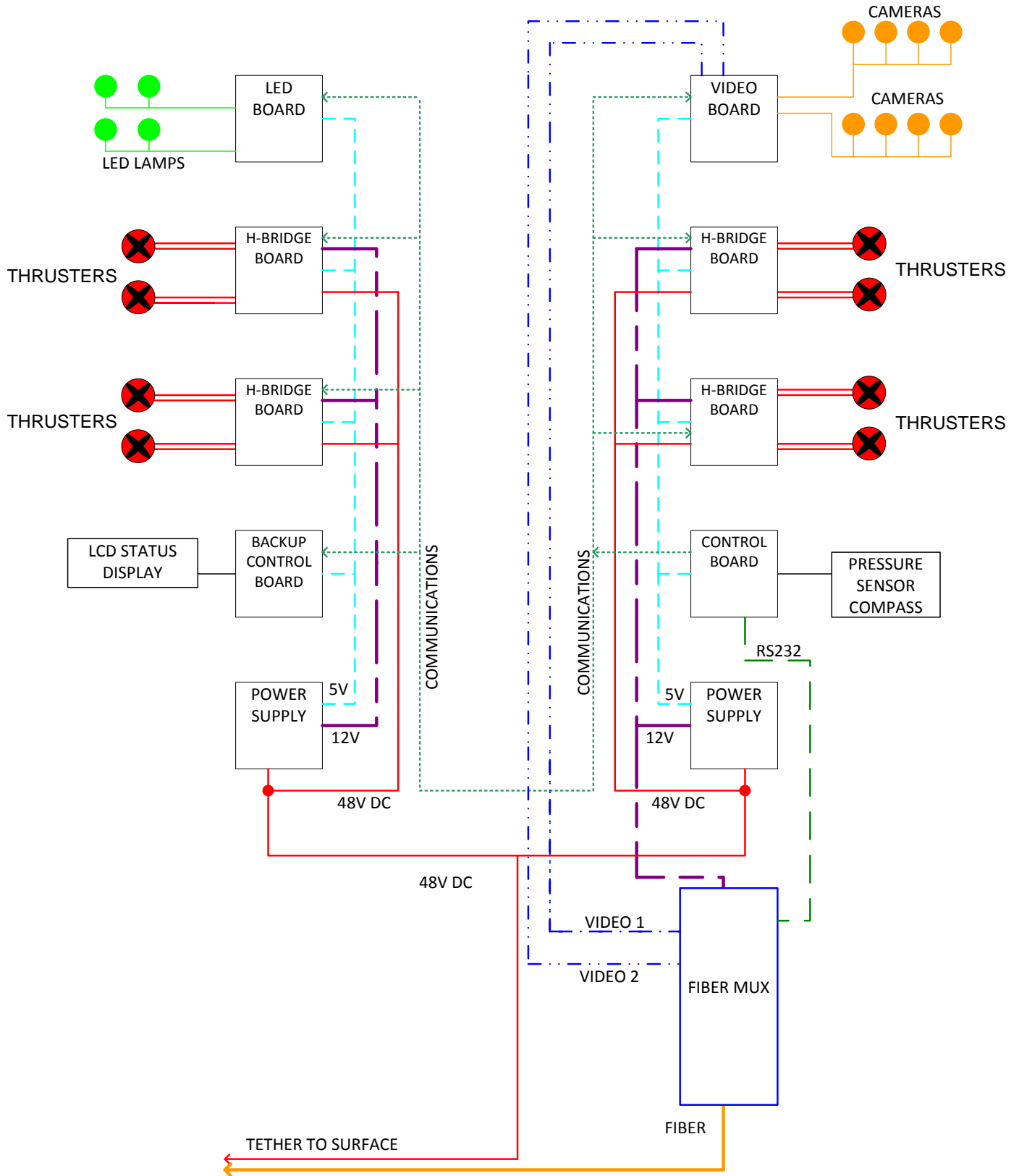

FIGURE 13 – CAD DISPLAY OF VIDEO SWITCH BOARD

# ROV ELECTRICAL SCHEMATIC



## SOFTWARE

There are two different programming environments involved for the software development: LabView, running on the surface PC, and PicBasic program on the ROV. We wanted to implement the most of the complex software with LabView instead of having it in the ROV in PicBasic code. This provides us with the ability to easily manipulate and modify the program as needed on the surface. Therefore, we kept the ROV programming in PicBasic as simple as possible giving us exactly what we need from the ROV during the mission. The biggest help for the software development came from the ROV simulators (See Figure 15 below) that we had built during the first semester of the class. Using the simulators, we were able to develop our software programs concurrent with the hardware development. We have utilized LCD screens to debug the programs and to understand what and how to implement the program code as written in the specifications. At the end, when the hardware was ready, we installed the programs on the chips, established communication between the ROV and the surface PC. The integration was successful the first time we tried.

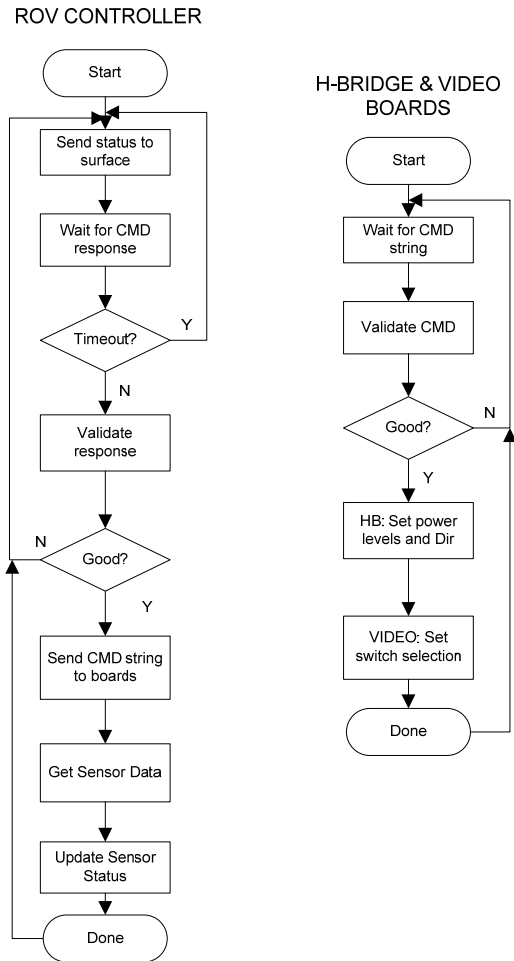

FIGURE 14 – ROV PROCESSOR SOFTWARE FLOWCHART

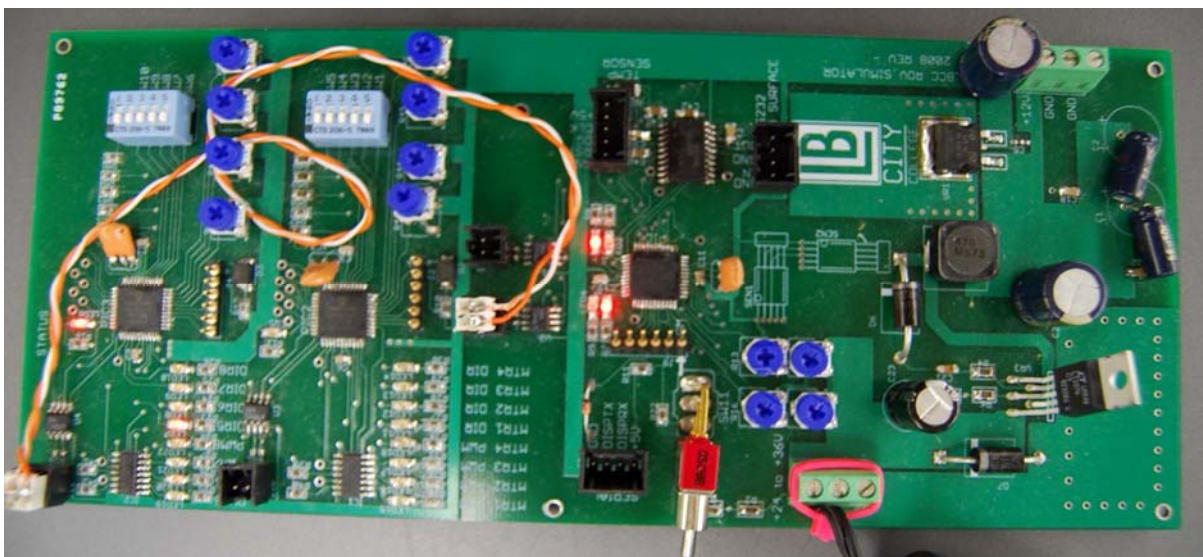

FIGURE 15 – ROV SIMULATOR BOARD FOR SOFTWARE DEVELOPMENT

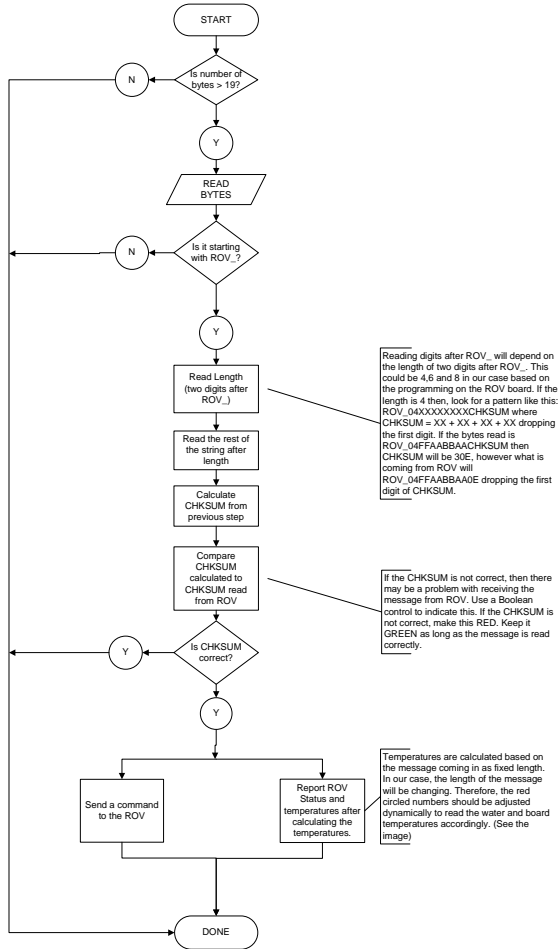

FIGURE 16 – LABVIEW SOFTWARE FLOWCHART

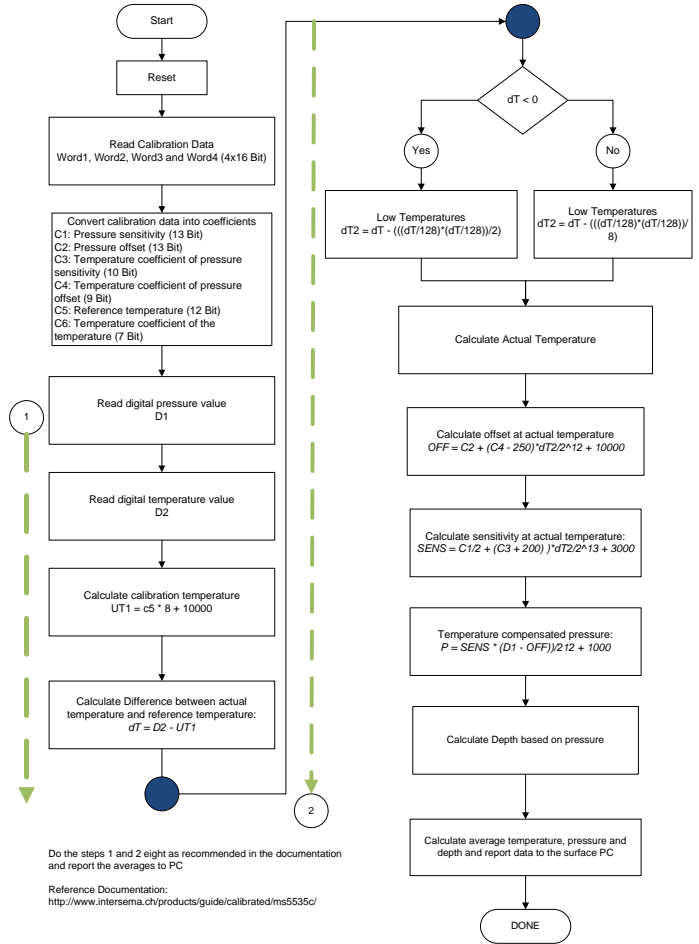

FIGURE 17 – PRESSURE SENSOR SOFTWARE FLOWCHART

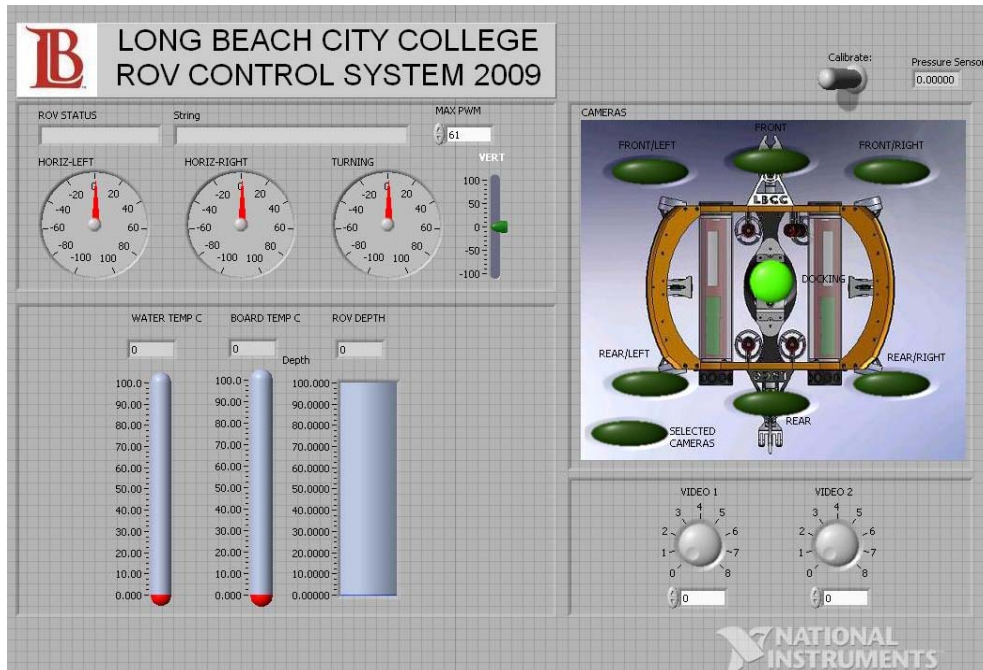

FIGURE 18 – LABVIEW FRONT PANEL CONTROL DISPLAY

## TROUBLESHOOTING TECHNIQUES

The ROV has provided us with many opportunities to develop and hone our electrical troubleshooting skills. Because we designed and built all of the electronics ourselves (learning tremendously in the process), we knew that this would increase the likelihood of errors. Initial testing after completion of our individual circuit cards was very positive. When it came time for systems integration with the ROV, we were thrilled that everything seemed to work well at first. But then one of the H-bridges ceased communicating with our controller. Out came the tools of the trade, our multimeter and the oscilloscope. Probing the board for proper voltage levels and communication signals, we were able to identify an intermittently functioning PIC chip. Fortunately, we had previously constructed spare circuit boards, so it was decided that we would swap cards so that we could continue testing. This extra board had only recently been completed and had not yet been tested, so a quick visual inspection for missing components or obvious solder bridges was done before we inserted the board into our motherboard. Upon power-up, there was a nearly immediate explosion, and we promptly powered down. After the thick smoke cleared, we discovered that an electrolytic capacitor had popped. Diagnosis revealed that the capacitor had been soldered in backwards! Repair was a simple matter of replacing the capacitor . . . or so it seemed.

In the following two weeks, we were still experiencing problems, each of which could be eventually traced back to the problem encountered with the capacitor explosion. Most recently, we discovered and repaired an elusive circuit board trace that had been damaged. Failed communication between the two electronics housings required that we trace the problem with the oscilloscope in a

systematic manner, looking for where the signal disappeared. This allowed us to isolate the problem to a specific length of trace between three connectors on our motherboard. Soldering a daisy chain of 30 gauge wire between the connector's pins thus bypassing the circuit board trace, solved our communication signal problem.

We also discovered that the voltage spike created by the exploding capacitor burned out a couple of our circuit board connectors. Upon inspection we discovered that the connector had failed, as several of the pins had broken causing a short on the board. Because of our concern about these connectors and in the interest of making our ROV more reliable, we have opted to forego the ability to easily remove our circuit boards and have directly hard-wired our circuit boards that carry the higher 48V loads.

Through these experiences we have learned to troubleshoot electrical and electronic systems by reading schematics, signal tracing with an oscilloscope, and voltage and continuity testing with a multimeter.



FIGURE 19 – ADAM FIXES A SOLDER BRIDGE ON A CIRCUIT BOARD

## SUBMARINE RESCUE AND THE U.S. NAVY

After the loss of the Russian submarine “Kursk,” the U.S. Navy put renewed focus on its submarine rescue capabilities. One design aspect for a new system was the ability to transfer rescued personnel under pressure. The U.S. Navy is ready for the future with the Submarine Rescue Diving and Recompression System (SRDRS). The SRDRS can be fully operational within 72 hours of being notified of a disabled submarine.

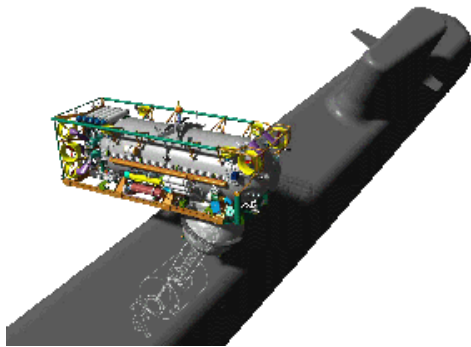

FIGURE 20 – SRDRS DOCKING WITH SUBMARINE

The SRDRS consists of four interdependent systems: Assessment/Underwater Work System (AUWS), Submarine Decompression System (SDS), Pressurized Rescue Module (PRM) and the Launch and Recovery System (LARS), which can be transported to any Vessel Of Opportunity (VOO). Currently there are over 2000 vessels that meet stability requirements. The first system deployed after a downed submarine is the Assessment/Underwater Work System (AUWS). This consists of an atmospheric diving suit rated to 2000 ft. Because the diving suit remains at one atmosphere; divers are able to return directly to the surface. This is used to locate and assess damage, clear any debris from hatches, and supply the disabled submarine with Emergency Life Support Stores that contain CO<sub>2</sub> absorbent, medical supplies, oxygen candles, food, etc. Pods are inserted into the submarine escape tower by ROVs or divers. The (SDS) has a hyperbaric transfer chamber, a deck transfer lock, and two 36-man decompression chambers, which personnel decompress under medical supervision to atmospheric pressure aboard the

surface vessel. The (SDS) will not be fully operational until 2012.

The (PRMS) consists of the following elements: Pressurized Rescue Module (PRM), a tethered, manned Remotely Operated Rescue Vehicle (RORV); the transfer skirt, which can achieve up to a 45° mating or docking angle while staying horizontal; and the control van which contains the (PRM) control system and power distribution systems. The PRM has an operating depth of 2000 ft. and can maneuver in currents up to 2.5 knots. The rescue capacity is 16 rescued personnel and two operators per trip. Thus, two trips are required to fill one decompression chamber. The Launch and Recovery System (LARS) consists of a stern mounted A-frame crane used to launch and recover the Pressurized Rescue Module (PRM). The LARS is capable of being operated deckside or from the control van.

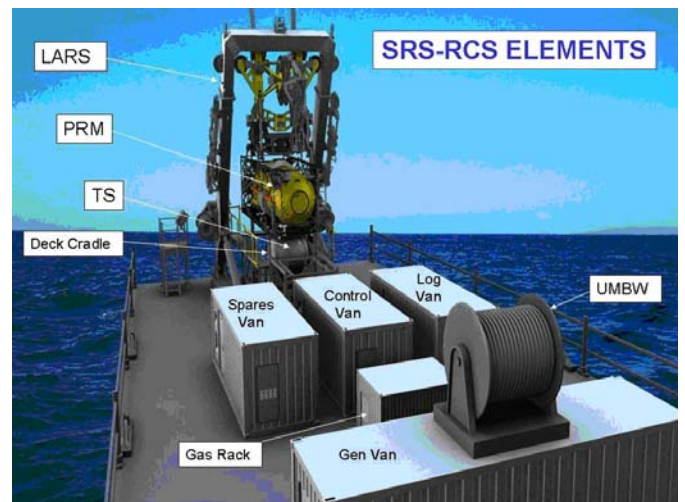

FIGURE 21 SRDRS DECK CONFIGURATION

In conclusion, the SRDRS was designed to rescue no more than 155 personnel from a disabled submarine. At least 20 PRM operators will be needed to complete no fewer than 10 dives to achieve the mission. The SRDRS could not have been achieved without the cooperation of numerous global contractors. They have created a system our men and women of the U.S. NAVY can use with pride.

## CHALLENGES

A significant challenge the team faced after testing the vehicle during the first pool session was finding the location of a leak in one of the electronics tubes. The team was able to narrow down the location of the leak to the connector end of the tube. However, visible inspection was unable to narrow down the location of the leak any further. The team proceeded to locate the leak by drilling and tapping the opposite end of the tube to accommodate a threaded pipe fitting that would later be plugged. The team used this hole to attach a vacuum gauge and a valve to the electronics tube. A vacuum pump was then attached to the valve and a vacuum was pulled on the entire electronics tube. After the vacuum had been pulled the valve was closed and the team began to listen for leaks while watching the vacuum gauge. If the vacuum was lost on the tube as indicated by the gauge the team knew they still had an open system. After the exact location of the leak was located the team was able to fill the hole with epoxy and then recheck the system by pulling a vacuum once again. This time the vacuum gauge did not change position indicating that the problem had been solved.



FIGURE 22 – VACUUM LEAK TEST SETUP

## LESSON LEARNED

During the course of designing and assembling the machine's thrusters a tolerance problem was found between the diameter of the thruster shafts and the bearings they rode on. On three of the eight thrusters being used, the shafts were too large to fit through the bearings. In an effort to make them fit they were turned down on a lathe in an attempt to remedy the problem. In retrospect this was a decision that was too hastily made. Technically the team had learned to verify all seal dimensions and run through calculations a second time if a problem was found. However, due to the time pressures of the thrusters needing to be finished and tested, the team made a split decision to modify them. The modification resulted in too much material being taken off of the shafts. However the shafts were still used due to the fact that they now seemed to fit the bearings and everything "felt" like it was working properly. The result of this mistake was that three of the thruster shaft seals now leaked. This cost the team valuable practice time and the time needed to make three new shafts. The positive side of this is that the team was able to take valuable technical and personal lessons from the mistake. On a personal level the team learned that when a problem is discovered letting time constraints and the desire to get things working right away can be a dangerous temptation. This temptation can often result in making bad decisions and ultimately delaying matters even further. The technical lesson taken from the situation was to stand by the original design numbers and trust in the design that had been already agreed upon. The team also learned how to troubleshoot the issues with the thrusters after performance and reliability issues began to be noticed. This skill is what allowed the team to ultimately trace the problem with the leaky seals back to the modified shafts so that they could be fixed.

## FUTURE IMPROVEMENTS

### High Power Connectors for the Circuit Boards

One of the major problems we encountered this year was shorting within the power connectors. The connectors were designed to handle 10 amps per pin, and each high current circuit had 6 pins. It was the delicate nature of the connector that was at the root of the problem. The connectors made the boards easily accessible; removing them too many times bent some of the pins causing shorts. This problem was fixed by hardwiring the boards to the motherboard. We used these connectors from the start since they were donated and were very small. For the video and control boards, they work perfectly. As a result of hardwiring the boards to the motherboard, if we want to swap out a board, six wires have to be unsoldered and resoldered.

Next year the plan is to use a ruggedized connector to eliminate this issue. If we use high amperage connectors that are rated well above 40 amps per pin, we should have no problems with maxing out the connectors. Additionally, the larger pin sizes will not bend as easily, jointly fixing the shorting problem and allowing the boards to be removed, maintained, and reinstalled regularly, without damaging the pins. Furthermore, the larger conductor pins will eliminate any issues with voltage drop through the connectors. This will provide full power to the supply boards and H-bridges. This will also help to reduce any power loss in the thruster circuits when higher current is applied. However, a ruggedized connector unit will be much larger than the smaller connectors that were used this year and will require a new circuit board configuration. Nonetheless, the ability to remove a board for maintenance is invaluable.

## ADDITIONAL TEAM PHOTOS



FIGURE 23 – RICARDO REMOVES A THRUSTER



FIGURE 24 – ADAM AND IAN TROUBLESHOOT THRUSTERS



FIGURE 25 – ANDY REVIEWS BAXTER'S GRIPPER DESIGN

## REFLECTIONS ON THE EXPERIENCE

### -Stuart Cook-

My time on the Robotics Team at Long Beach Community College has been both rewarding and challenging for me. The contributions of the entire team from design to completion are awe inspiring. I haven't experienced teamwork or camaraderie like this since active duty military.

We were presented with many challenges including control system design and production. First we had to create a mobile tether rack that now can be carried as a backpack. Also, the control box underwent many revisions over the semester. This includes all the power and control systems for the ROV. In the end we ended up with a fully portable and stable platform to operate the ROV.

The technical skills I have gained being part of this team have played over into the Electrical Program classes in which I'm currently enrolled. These skills include Solid Works design software, designing and implementing parts and electrical and pneumatic control systems for the ROV. The most underrated skill I gained was soldering circuit boards and wiring connections.

The Robotics Technology Program has greatly furthered my knowledge of the Marine and ROV Technology field. I look forward to the many challenges and skills that I will add to my repository of knowledge.

### -Harleigh Williams-

Rare are the opportunities that permit people to pursue their adolescent aspirations. Such has been my delight and challenge over the last ten months since returning to college to pursue my engineering degree and subsequently discovering the underwater robotics program at LBCC. It sounds like a cliché to say that I have learned (or re-learned) a multitude of things working on this project, but it is nevertheless true. One aspect that I enjoy most is the analytical thinking that is requisite in solving certain problems or meeting certain design goals and having the opportunity to communicate these ideas bilaterally with my teammates. It is so refreshing to hear about how others may approach the same problem but from different angles. As our experiences have taken us beyond the classroom, I have enjoyed many interpersonal experiences that have lead to the formation of bonds of respect with some and amiable friendships with others, as we collectively work toward our common goal. I have also learned to become more involved in the Associated Student Body government as our team's senate representative. Yet another window has opened providing greater involvement and participation in college that I have no doubt will make me a better person for the experience. So one should now understand when I say that being a member of this team has been so much more than merely designing and building a competition devastating underwater robot. It has been a life-enriching experience.

BUDGET/EXPENSE SHEET

2009 LBCC ROV Financial Report					
	Part	Quantity	Reused Value	Donated Value	Cost
1	Joysticks	2			\$ 14.53
2	Touch Screen Monitors	2			\$ 300.00
3	Indicator Light	1			\$ 2.75
4	40A Circuit Breaker	1			\$ 12.76
5	Fiber connectors & Cable	1			\$ 46.35
6	Air Line connectors	1			\$ 1.89
7	120V Outlet	1			\$ 2.96
8	Aluminum Stock	1		\$ 136.40	\$ 80.00
9	Fiber Mux	1		\$ 2,800.00	\$ -
10	Air Manifold	1	\$ 375.00		\$ -
11	Air Regulator	1	\$ 150.00		\$ -
12	48V to 24V supply	1			\$ 24.95
13	Mouse	1	\$ 10.00		\$ -
14	Keyboard	1	\$ 10.00		\$ -
15	Computer	1	\$ 300.00		\$ -
16	Computer Monitor	1	\$ 150.00		\$ -
17	Nema Twist lock connectors	1			\$ 4.75
18	1/4" standard male air connector	1	\$ 1.89		\$ -
19	Stainless steel hardware				\$ 143.65
20	1/8 inch sheet metal				\$ 55.81
21	Thruster motors	10		\$ 1,488.00	\$ 1,488.00 *
22	Thruster components	40		\$ 2,733.32	\$ 2,733.32 *
23	1-inch low-density PVC				\$ 162.38
24	Electronic Tray Metal components	2		\$ 1,775.30	\$ 1,775.30 *
25	Electronic tubes	2			\$ 53.31
26	Electronic Components			\$ 693.00	\$ 619.95
27	Camera housing metal	8		\$ 22.69	\$ 181.52
28	Camera housing components	16			\$ 146.72
29	Cameras	8			\$ 332.00
30	Connectors	36			\$ 467.64
31	Cables	16			\$ 37.89
32	Cylinders/components				\$ 47.98
33	Tether	25 m		\$ 450.00	\$ -
34	Backpack frame	1			\$ 18.75
35	Command/Control Case	1			\$ 201.00
36	Metal Anodizing Services			\$ 500.00	\$ -
37	Burton Connectors			\$ 750.00	\$ -
38	Metal Welding Services			\$ 275.00	\$ -
39	SolidWorks CAD Software Donation			\$ 10,200.00	\$ -
40			\$ 996.89	\$ 21,823.71	\$ 8,956.15
41	Fundraising	\$ 9,645.87			
42	Electrical Dept Funds	\$ 1,173.46			
43	Total Budget	\$ 10,819.33			
44	Amount Spent	\$ 8,956.15			* Sponsor provided the team with deep discounts off their list prices
45	Balance	\$ 1,863.18			

## REFERENCE SOURCES

### **Submarine Rescue Reference Sources**

<http://www.globalsecurity.org/military/systems/ship/systems/srdrs.htm>

<http://www.oceanering.com/otech/.asp?id=1077>

[http://www.oceanworks.com/cms/pdfs/OW2002\\_Pressurized%20Rescue%20Module.pdf](http://www.oceanworks.com/cms/pdfs/OW2002_Pressurized%20Rescue%20Module.pdf)

<http://www.oceanworks.com/cms/pdfs/9-3%20ELSS%20Transfer%20Pod.pdf>

<http://www.oceanering.com/brochures/Pdfs/SRS.pdf>

### **General Reference Items**

SI Unit Definitions <http://physics.nist.gov/cuu/Units/units.html>

### **Programming and Hardware Reference**

LabView Reference <http://www.ni.com/labview/>

LCD Display Specifications <http://72.167.145.12/specs/NHD-0420D3Z-FL-GBW.pdf>

ROV Simulator Schematic <http://www.vikingexplorer.org/vikingftp/ROV-SIM.pdf>

Pressure Sensor Data Sheet <http://www.intersema.com/site/technical/ms5535.php>

Compass Chip Data Sheet <http://www.ssec.honeywell.com/magnetic/hmc6352.html>

SPI Programming Reference <http://www.vikingexplorer.org/vikingftp/EDN071203-spi.pdf>

PicBasic Pro Programming Reference <http://www.melabs.com/downloads/pbpm304.pdf>

Pic Processor Data Sheet <http://www.vikingexplorer.org/vikingftp/PIC18F2431-4431.pdf>

### **Electrical Wiring/Development Reference**

Optelecom Fiber Optic Mux <http://www.vikingexplorer.org/vikingftp/TETRA.pdf>

CNC Router Reference <http://www.vikingexplorer.org/vikingftp/CNCRoutertxt.pdf>

EagleCad Circuit Board Layout Software <http://www.cadsoftusa.com/>

LMD18200 H-Bridge Chip <http://www.national.com/ds/LM/LMD18200.pdf>

60V Switching Regulator

<http://www.linear.com/pc/downloadDocument.do?navId=H0,C1,C1003,C1042,C1033,P1006,D2659>

5V Regulator Chip <http://www.st.com/stonline/products/literature/ds/2143/l7805.pdf>

RS-232 Interface Chip <http://focus.ti.com/lit/ds/symlink/sn65c3222.pdf>

Video Switch Chip <http://www.intersil.com/data/fn/fn3679.pdf>

RS-485 Chip <http://www.linear.com/pc/downloadDocument.do?navId=H0,C1,C1007,C1017,P2064,D1718>

LED Current Source <http://www.diodes.com/datasheets/ZXLD1362.pdf>

### **Mechanical Reference**

Trelleborg Sealing Solutions <http://www.tss.trelleborg.com/com/www/en/homepage.jsp>

Mechanical Drawings for Hardware <http://www.mcmaster.com>

**ACKNOWLEDGEMENTS**

The Viking Explorer team would like to thank the following companies and organizations for their contributions to making this year’s ROV a success. Without your donations none of this would have been able to come together. We appreciate your support of our project and our education. **THANK YOU!**

<b>Company/Organization</b>	<b>Donation</b>	<b>Value</b>
<b>SOLIDWORKS</b>	<b>20 COPIES OF STUDENT LICENSES &amp; 10 SEATS of SOLIDWORKS PROFESSIONAL</b>	<b>\$10,200</b>
<b>DATUM CONTROL COMPANY</b>	<b>CNC MACHINING SERVICES @ 50% DISCOUNT</b>	<b>\$4,508.62</b>
<b>OPTELECOM-NKF</b>	<b>FIBER OPTIC VIDEO/DATA MUX</b>	<b>\$2,800</b>
<b>PORTESCAP</b>	<b>THRUSTER MOTORS 8EA \$350 MOTORS FOR \$160/EA</b>	<b>\$1,488</b>
<b>LBCC FOUNDATION</b>	<b>TRAVEL FUNDING</b>	<b>\$1,000</b>
<b>BURTON ELECTRICAL ENGINEERING</b>	<b>WATERPROOF CONNECTORS</b>	<b>\$750</b>
<b>ADVANCED CIRCUITS</b>	<b>CIRCUIT BOARD MANUFACTURING</b>	<b>\$693</b>
<b>LUBECO</b>	<b>ALUMINUM ANODIZING SERVICES</b>	<b>\$500</b>
<b>STANDARD METAL PRODUCTS</b>	<b>ALUMINUM WELDING SERVICES</b>	<b>\$250</b>
<b>ALLSCAPE LIGHTING</b>	<b>ALUMINUM STOCK</b>	<b>\$136.40</b>
<b>LBCC MACHINE TOOL STUDENTS &amp; MICHAEL AVILA, INSTRUCTOR</b>	<b>STUDENT LABOR FOR CAMERA HOUSINGS</b>	<b>Root Beer</b>
<b>MATE</b> Marine Advanced Technical Education Center	Providing us with a opportunity to expand our knowledge and open life-changing career paths.	<b>PRICELESS!</b>

**LONG BEACH CITY COLLEGE ELECTRICAL DEPARTMENT AND ELECT 230C STUDENTS**

<b>Last</b>	<b>First</b>	<b>Hours</b>
Jasper	Ian	737
Ramsey	Adam	567
Hutchinson	Baxter	548
Williams	Harleigh	535
Walsh	Andy	511
Unlu	Ferruh	473
Cook	Stuart	252
Casaine	Ricardo	185
Whitaker	Amethyst	142
Brooks	William	135
Grefe	Nathan	117
Bennet	Russell	72

<b>Last</b>	<b>First</b>	<b>Hours</b>
Griffin	Craig	72
Henson	Keith	72
Hulett	Chelsey	72
Main	Nara	72
Martinez	Raul	72
Morones	Eddie	72
Rico	Peter	72
Torres	Alex	72
Vongkoth	Alex	72
Wagner	Mark	72
Khalil	Yasin	49
<b>Total Hrs up to 5/22/09</b>		<b>5,033</b>