

# Rov Engineering Report

ROV Name: Squalo Esca (Italian for Shark Bait)

School Name: Riviera Beach Maritime Academy

Team Members:

Miciah Wells

Corey Green

Taylor Katz

Gabriel Alejandro

Sabrina Bowser

Lexxa Katz

Jessica Lawler

Isabella Pinos

Alexander Thompson

Advisor Names:

George Bradbury

David Sellepack

Mentor Name:

David Sellepack

Table Of Contents:

Budget/Expense Sheet

Electrical Schematic

Flow Chart of ROV Software

Design Rationale

Challenges

Troubleshooting and Techniques

Lessons Learned/Skills Gained

Future Improvements

Submarine Rescue

Team Reflections

References

Acknowledgements

## **Abstract:**

This years ROV was built from recycled parts from last year. We cut down the tube size, stabilized the floatation material, adapted the control system to power the ROV at 48 volts at the surface, and reduced the power to 12 volt through the tether and powering the cameras from the DC/DC converter. Not much money was spent on it except for repairs on the DC/DC converter (a manufacturing cold solder to a resister was a diagnosed problem early on). All other parts were constructed by materials in our school shop to perform the missions. Our team worked hard on completing the project and managed to do it in time. We learned to work together on tough assignments. Some challenges we went through are trying to complete the tasks given within the time limit. We built devices that could do multiple tasks like a claw that would open the subs doors and hatch.

The ROV was constructed of 4 Minn-Kota trolling motors with 30 lbs of thrust each, a PVC frame and water bottles as floatation. We sealed the electronics in a water tight box connected to a tether. The tether led to an onshore car battery connected to the DC/DC converter to knock it down to 12 volts of electricity at 40 amps to the ROV.

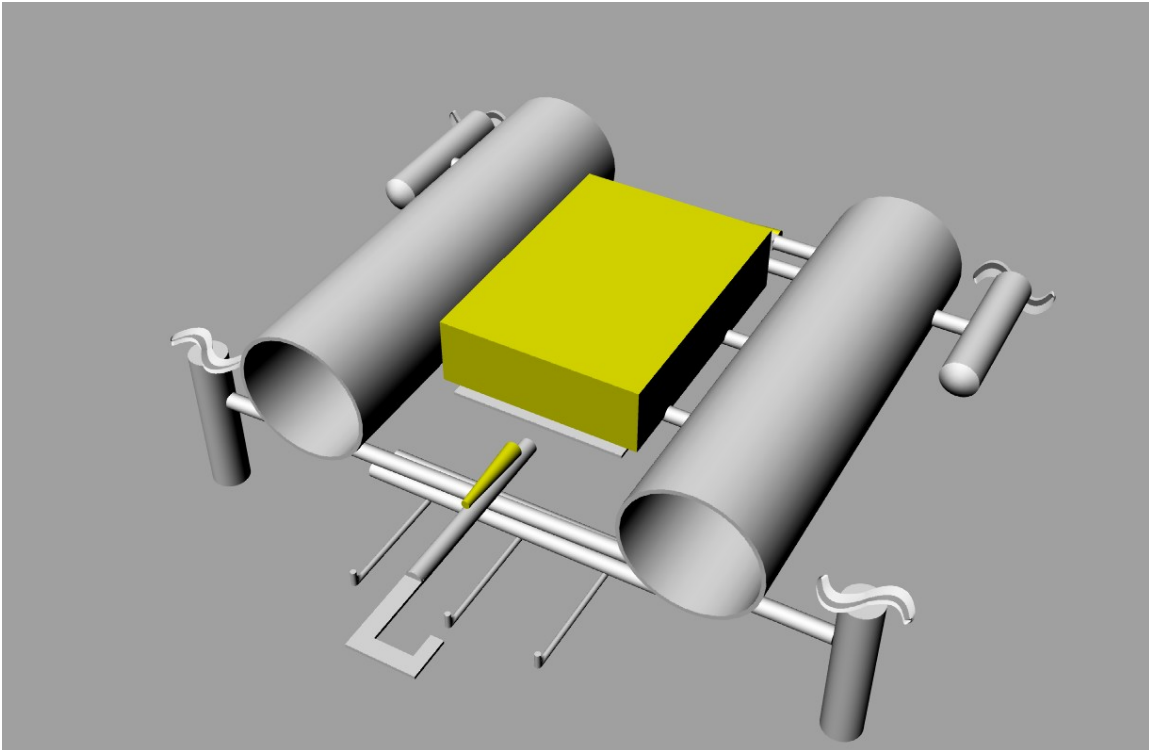

3D CAD Drawing of 2009 ROV



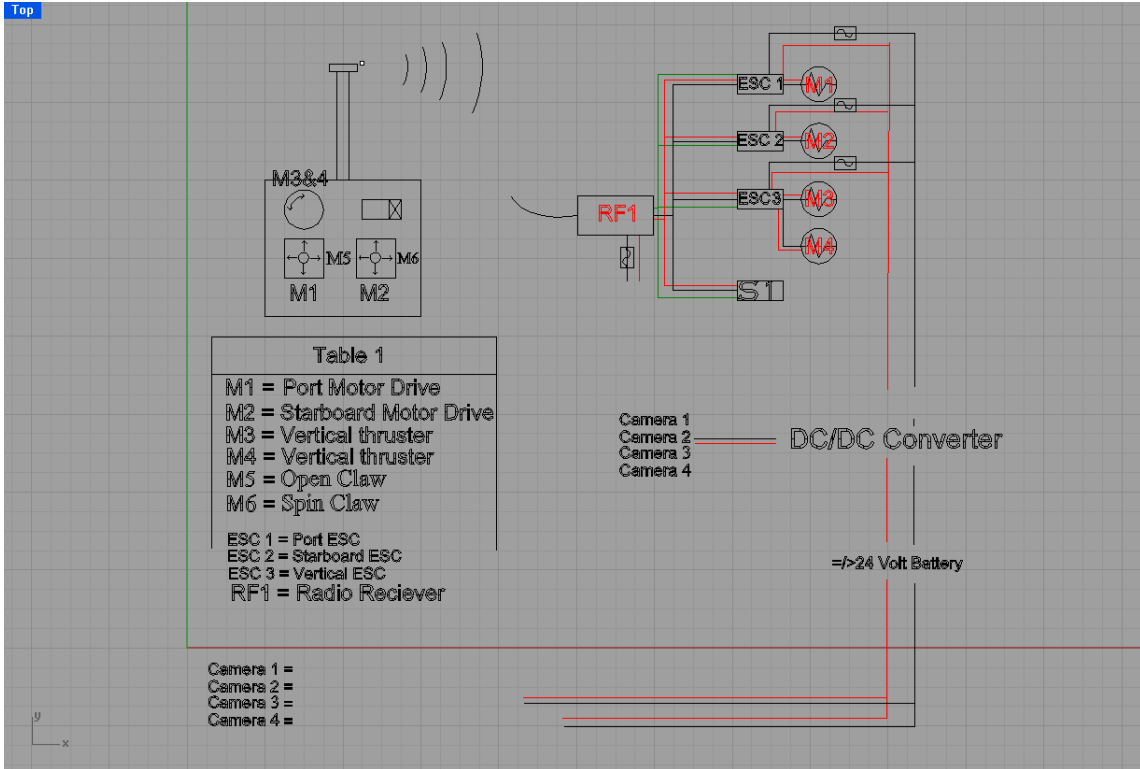

**ROV Wiring Diagram**

**ROV Flow Chart**

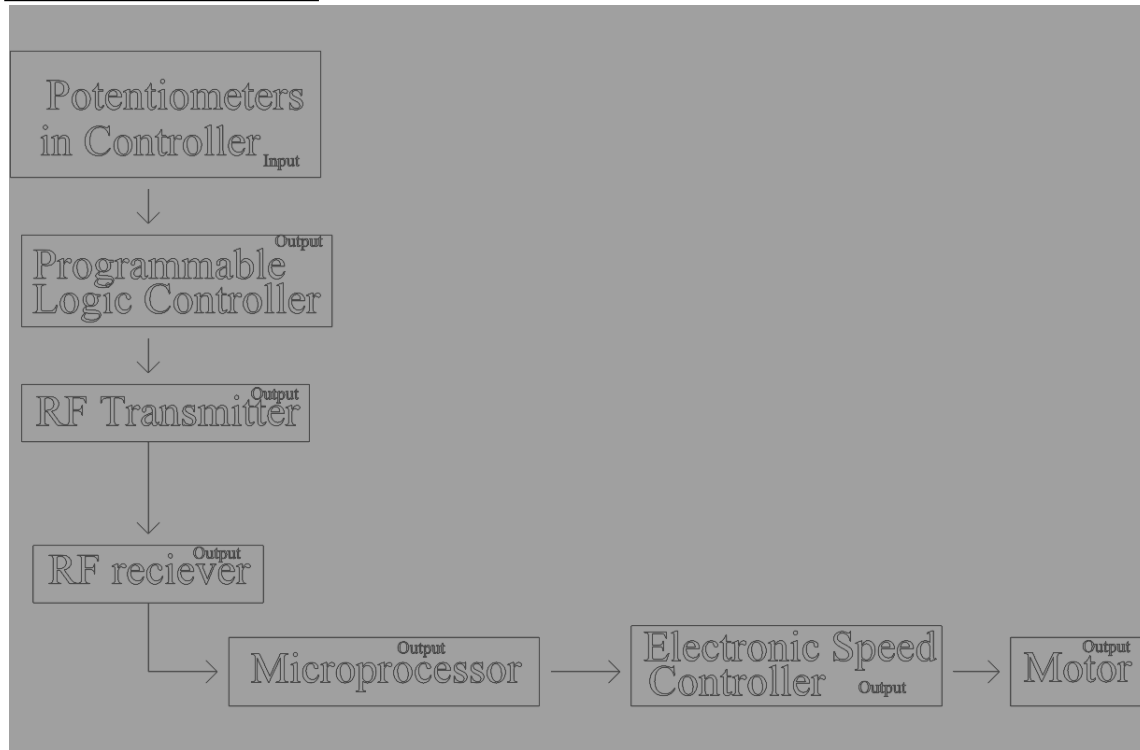

Top

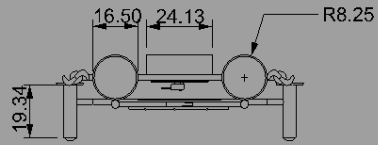
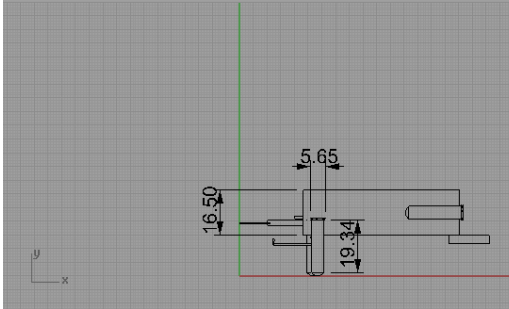
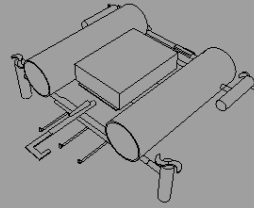
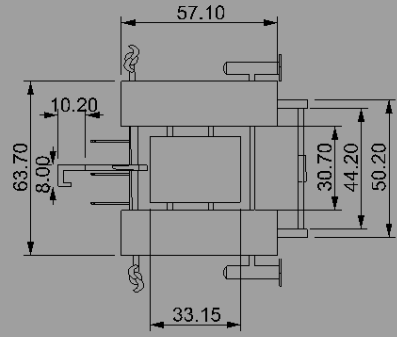

**Dimensioned Print of ROV (cm)**

## Design Rationale

To show our method of thinking, we set up a table to break down each of the individual missions:

Survey and inspect the Submarine for damage Descend to the submarine Pilot the ROV around the complete perimeter of the submarine Locate a damage point on the video monitor(s)
Pod posting Turn the hand wheel to unlock hatch Open hatch Remove an ELSS transfer pod from the carousel assembly Insert the pod into the escape tower Close the hatch Turn the hand wheel to unlock the hatch
Ventilation Transport the airline to the submarine Open the hatch Insert the airline into the inlet valve connection Open the valve to allow air flow Remove the airline from the inlet valve connection Close the hatch Return the airline to the surface
RORV(remotely operated rescue vehicle) Build and incorporate a transfer skirt into the ROV Mate the transfer skirt to the escape hatch and hold position Undock the transfer skirt from escape hatch

Basically, we looked at all the small things we needed to accomplish for each task and designed the ROV and tools around these tasks. We knew we had to put some attachments like the skirt to accomplish the task RORV. We also made a new arm and hand to open and close hatches and grasp the air hose. Another consideration we looked at, was having the ROV design as modular as possible for future competitions.

As such these are the tools decided on

We needed

Prongs to pick up the pods (air capsules)

2 claws to open the hatch, turn the valve and also to pick up the air hose

1 hook to open the hatch and turn the valve

1 skirt is to land on the sub

1 camera to see different angles

This year's ROV's control system is rather simple. We have an airplane remote controller with an S-cable carrying a signal down to an RF receiver in the dry box. The RF receiver then sends the signal to the 3 electronic speed controllers, one for the port thruster, one for the starboard thruster, and one for the two vertical thrusters.

In order to complete the tasks and navigate with optimum efficiency we decided to use 3 cameras, two cameras are mounted at the vehicles bow for directional control and navigation, another camera facing forward is mounted in the lower stern, to allow viewing of the transfer skirt  
These are the prongs needed to pick up the pods (air capsules)....

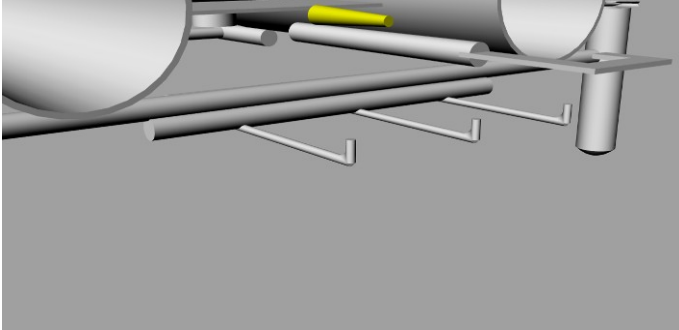

This is the hook we need to open the hatch and turn the valve.....

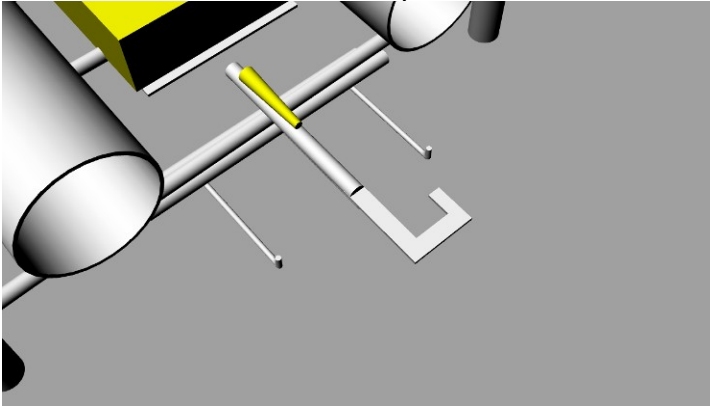

This is the skirt needed to attach to the sub and transfer people to safety.....

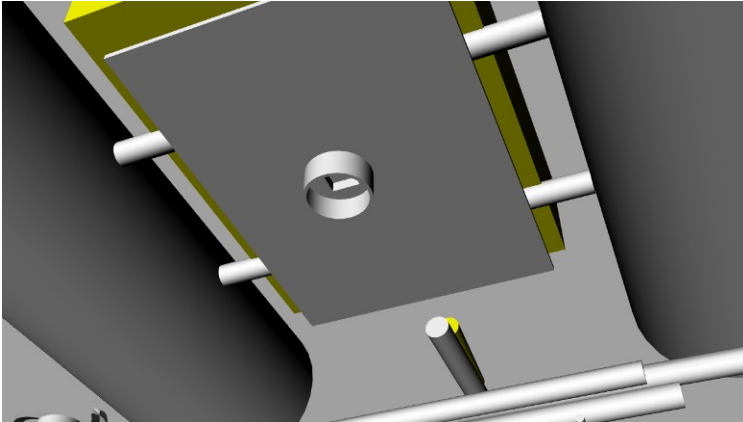

## Challenges

One challenge we experienced was re-tethering the ROV system's cords. We had to cut all zip ties and remove all flotation to remove two sets of wires that had connected cameras to television monitors at the surface. Therefore, a couple of team members extracted the wires and went back to attach the newly bought cameras, applying new zip ties and new flotation to keep the tether effectively away from the propellers. We soon realized that the flotation was tied too tightly, causing us to remove them once again. Soon we had it with brand new flotation and weaving the camera cords back through the length of wire.

Another challenge was the skirt on the bottom of Squalo Esca. We had originally placed it too high up, causing us great difficulty in settling onto the "escape hatch." We quickly decided that adding a spacer was best to successfully mount the hatch. After much debating, we settled on adding a piece of wood on the top of the skirt (between it and the ROV) to reach down farther.

Also, we increased ROV maneuverability by cutting the ROV nearly in half. This allowed the ROV to be easier for the driver and to accommodate this year's MATE competition missions. We re-measured the ROV, placing the control box closer towards the new midsection.

## Troubleshooting

We realized, when we first tested the ROV in water, that while we were downsizing Squalo Esca, we wired it backwards. We fixed this problem by evaluating the damage done, luckily we had to only rewire the leads to correct the problem. We had a camera malfunction, also, which is why we re-tethered the cords. We had to acquire new cameras and add another one to conveniently visualize the skirt on the bottom and the claw for one of the tasks. We had to rebalance the ROV by placing plastic bottles into the pontoons equally on each side and slowly reopened the bottles until it was balanced. Another problem we encountered was a broken D/C D/C converter. One of our advisors discovered a cold solder on a resistor, causing the resistor to come loose and shake around inside of it.

## Lessons Learned/Skills Gained

We had a few technical problems, which caused us to pay more attention in wiring the electrical box. One of the teammates had difficulty wiring the box, and caused the ROV to flip and do summersaults. This experience caused us to learn more about wiring the ROV correctly.

Another lesson was learned after the D/C D/C converter broke. Our mentor sent the converter to Zahn Electronics and learned it had a cold solder on one of the resistors. They charged us \$80 for their mistake. We learned to always check a purchase to make sure it is in an accurate, working condition.

A meaningful skill we learned as a team is working together. It was difficult at times, but we stuck it out. After a few weeks into working on the ROV, we had gotten over each other's differences and cooperated to making, in our opinion, an amazing ROV that will hopefully win the competition.



ROV Nearing Completion

### Future Improvements

Swiveling props would be a leap forward in maneuverability for the ROV. This enhancement would enable the ROV to move at a greater dexterity. The swiveling props would allow for the pilot to hit angles more precisely during competitions. Also, to further improve precision we could change the way the pilot controls the ROV.

Another improvement would be to make a transition from radio receiver to a programmable logic controller (PLC). For example instead of moving a joy stick to the left, the pilot can push a button manipulating the ROV to turn in the desired direction. The PLC controls would lessen errors that might be performed by the pilot. Manifesting these improvements would make each task and mission easier overall.

## Submarine Rescues



Working and Living aboard a submarine is an extremely dangerous job. Hundreds of feet below the surface of the ocean, one has thousands of pounds of pressure squeezing every inch of a submerged object. The slightest mechanical, electronic, or structural failure can spell certain doom for crewmembers.

Early submarines were, for lack of a better word, death traps, they had next to no way to safely escape, and the few crew members who might actually survive a swim to the surface after escaping faced a likely severe case of decompression sickness, where nitrogen bubbles form in your body and can cause heart attacks or paralysis.

Early rescue attempts used diving bells, which were giant, steel, bell-shaped vehicles in which divers would ride down to where the sunken sub was, and then the divers would rescue the stranded submariners using 'Momsen Lungs' which were primitive rebreathers.

Nowadays, the rescue techniques are quite a bit more advanced. For starters, on the subs themselves, there are much more rigorous safety measures than in the past, tightly controlling the manufacturing process of various parts to avoid catastrophic failure.

As for actual rescue, recently, ROV's have come into play for rescuing stranded submariners. Going back to the diving bell technique, the ROV's are piloted down from the surface with a small group of rescuers who handle docking the ROV and tending to the evacuees. After the crew is aboard, the ROV is piloted safely back to the surface. The biggest advantage to using an ROV-based system, is the fact that it doesn't require special rescue vessels specifically outfitted for submarine rescue to function. Rather, any ship that has the capability of handling an industrial-sized ROV can perform rescue operations.

## Team Reflections

Micaiah Wells

Position: Captain

Personal Profession: Student

Point of View on R.O.V:

Learned that it's good to actually show up to R.O.V meetings.

Liked how the R.O.V's design was minimized from last years design.

Would improve on R.O.V's control would run it on Programmable Logic Controller instead of using an old airplane controller.

Corey Green

Position: Co-Captain

Personal Profession: Student

Point of View on R.O.V: Learned that if you want something done it's better to get help from someone on your team that knows what they are doing.

Liked doing the CAD design and dimensioning for R.O.V.

Would improve on the control thinks using a X-Box controller would be a lot easier because of the experience he has with one.

Taylor Katz

Position: Secretary/Treasurer

Personal Profession: Student

Point of View on R.O.V: Learned that if you have little patience you will get little done correctly so take your time.

Liked that we could take time on this years model because it was just a remodel of last years R.O.V.

Would improve on buoyancy factor. Thinks we spend a lot of time working on getting the R.O.V buoyant and if we can reduce the time spent on that we would be done a lot faster.

Alexander Thompson

Position: Team Member

Personal Profession: Student

Point of View on R.O.V: Learned how to use various tools while working on this years R.O.V.

Enjoyed piloting the R.O.V. would improve on R.O.V controls. Thinks we spend a lot of time zeroing the controller.

Gabriel Alejandro

Position: Team Member

Personal Profession: Student

Point of View on R.O.V: Learned how to wire the tether used for the R.O.V.

Liked how it moved faster in the water as apposed to last year's model.  
Would improve on the R.O.V's maneuverability. Think we could complete missions at  
a faster rate if the R.O.V was better at turning.

Lexxa Katz

Position: Team Member

Personal Profession: Student

Point of View on R.O.V: Learned how teamwork is the key to getting  
the job done.

Liked that it's a great learning experience.

Would improve on teams working rate.

Sabrina Bowser

Position: Team Member

Personal Profession: Student

Point of View on R.O.V: Learned that if you work at something you  
can get it done.

Liked how we can have a hands on approach with underwater robotics. Also  
that our team decided to cut down on the bulk of R.O.V making it easier to  
lift on land and quicker in the water. Would improve on the tether construction to  
were we don't have to redo the whole tether every time we make a mistake.

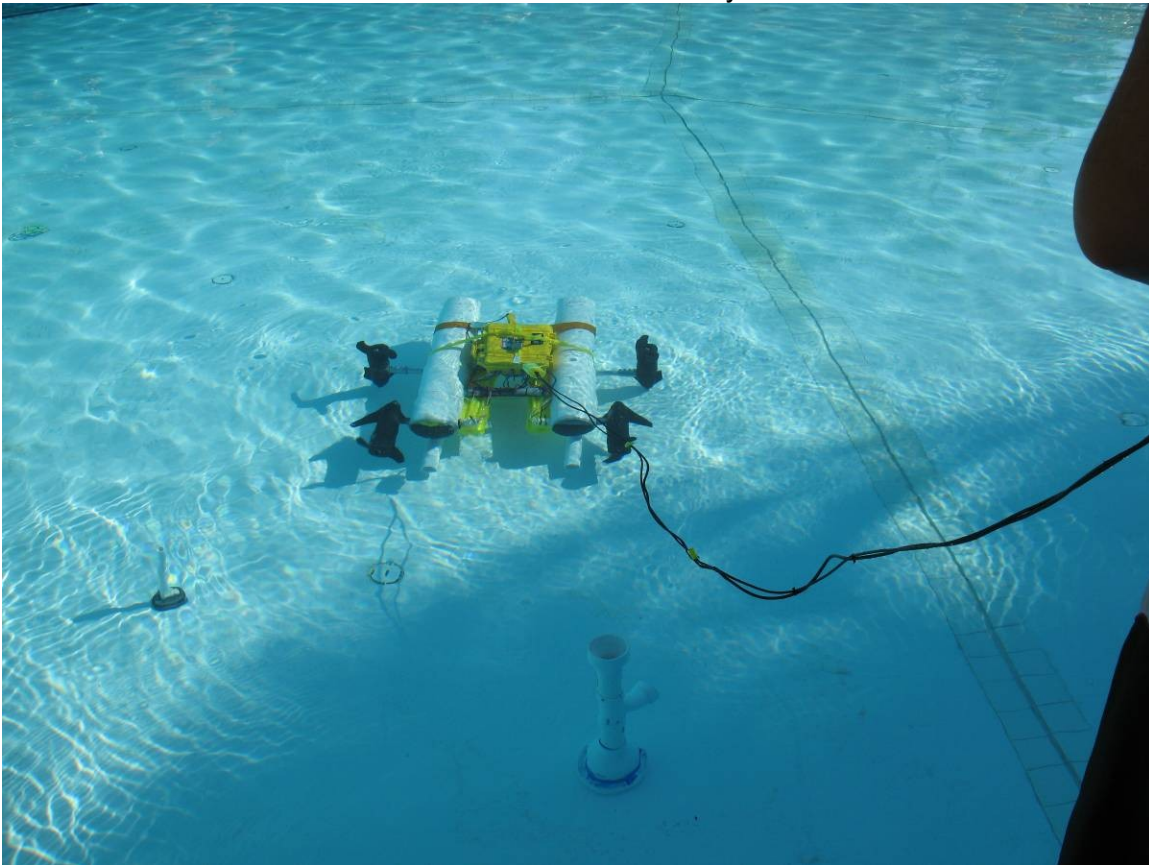

## **Acknowledgements**

We Would Like To Give Thanks To The Following:

*Riviera Beach Maritime Academy* ~ Provided facility and equipment, along with teachers to oversee the team's progress.

*MATE* ~ For organizing the competition and allowed us to participate.

*Florida Regional's* ~ For allowing us to compete in the competition this year.

## **References**

Information about submarine rescues and safety obtained from the following

National Geographic-

[http://www.nationalgeographic.com/k19/disasters\\_detail3.html](http://www.nationalgeographic.com/k19/disasters_detail3.html)

MATE

[http://marinetech.org/rov\\_competition/2009/2009\\_MISSIONS\\_COMPLETE\\_FINAL.pdf](http://marinetech.org/rov_competition/2009/2009_MISSIONS_COMPLETE_FINAL.pdf)

Steve Jackson – Former reactor operator aboard a nuclear submarine