

The Aquatic Swag

ROV Team

**Boys & Girls Clubs of St. Joseph County
South Bend, Indiana**

Team Members

- * Allen Miller
- * Anthony Foster
- * Asata McIntosh
- * Curtis Anderson
- * Devyn Jackson
- * Gemma Van Jacob
- * John Mozee
- * Joseph McCool
- * Matthew O'Neal
- * Nate Miller
- * Raven McCool
- * Valerie Whiteman

Instructors

- * Laura Batt
- * Lucinda Reese

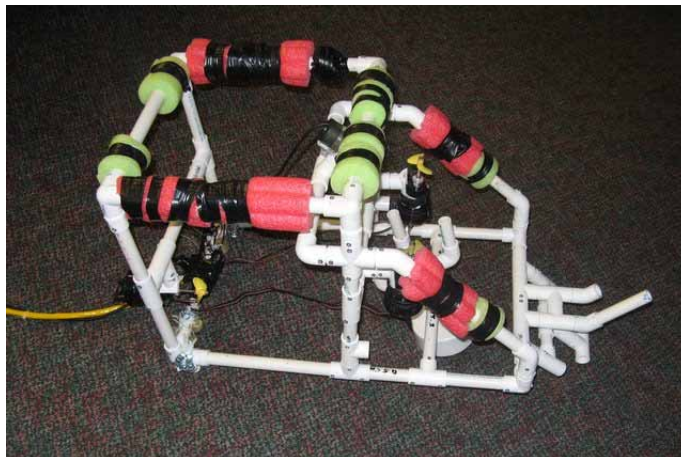

Lil Swag ROV

Table of Contents

Section Title	Page Number
Abstract	1
Missions Summary	2
Design Rationale and Process	3
Payload Tools	4
Vehicle Systems and Features	5
Challenges	6
Troubleshooting Technique	7
Lessons Learned	8
Future Improvements	9
ELSS Pods in the Real World	10
Reflections	11
Acknowledgements	13
Appendix 1: Budget	A1
Appendix 2: ROV Statistics and Sketch	A4
Appendix 3: Control Box Electrical Schematic	A5

Abstract

It was January 29, 2009, when a group of kids from elementary to high school gathered for the first meeting of the ROV team at the Boys & Girls Clubs of St. Joseph County. Who knew that this group would go on to win a regional ROV competition?

At our first meeting we talked about what we would need to do to get ready for the MATE competition. We were going to have to build an ROV from scratch to successfully complete a submarine rescue mission.

For the next few weeks we designed the ROV by sketching in notebooks and using K'Nex to figure out the shape. Then we used materials such as PVC pipe to make the actual robot. We spent several weeks making the ROV, which we named Lil Swag. Then, finally, it was time to test our beloved ROV in the water.

At practices we have two pilots, two tether managers, and two people who help set up and take down the ROV. Other team members use a smaller ROV to watch what Lil Swag is doing. We got a fair amount of practice time in before the regional competition in Chicago.

We were definitely the underdogs at the regional competition. But when we got into the water, it was like nothing could stop us. No other team did as many parts of the missions as we did. And when we heard we won, well, we were like a bunch of kids on Christmas day!



Figure 1: Team photo just before leaving for the regional competition

Missions Summary

The first mission we have to do is to go around the submarine and find damage points using the camera. We usually go around the submarine halfway and then back up and go around the other half.

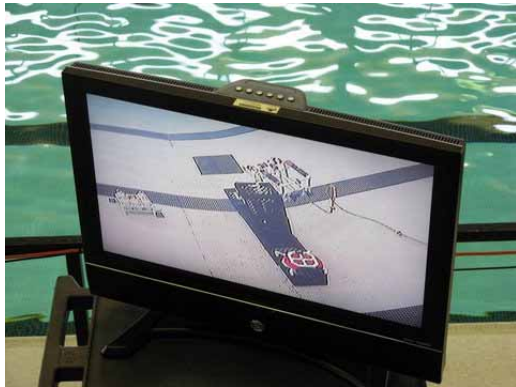

Figure 2: Lil Swag looking for damage points at the regional competition

The second mission we do is to land the mating skirt on the escape hatch. Before we do the second mission, the tether managers have to adjust the camera by pointing it at the transfer skirt.

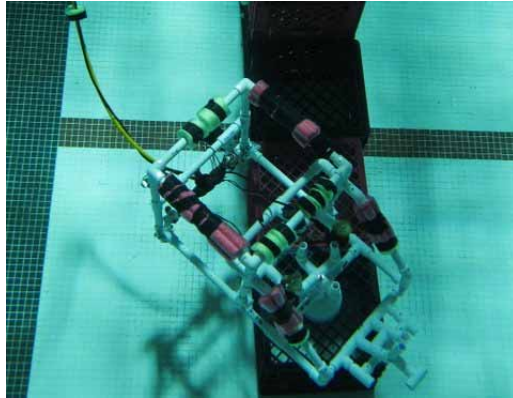

Figure 3: Mating the transfer skirt to the escape hatch during a pool practice session

After the second mission we bring the ROV to the surface again so the tether managers can make some changes. They take off the transfer skirt and flip it over so the quad turner is on the bottom. This lets the pilot see the quad turner better. The pilot drives over to the hatch and turns the wheel with the quad turner. To open the hatch the pilot uses the adjustable tee holder. Picking up the ELSS pods takes skill and precision. We use the pod raiser, which is a piece of PVC pipe with floatation in it to add buoyancy. Each pod must be put carefully in the milk crate so they all fit.

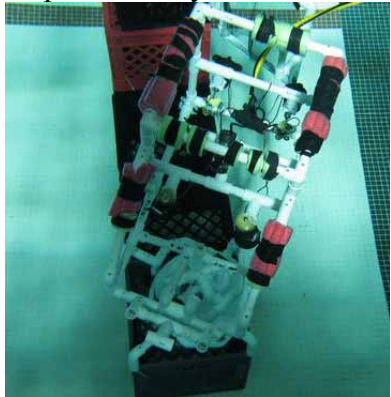

Figure 4: Opening the hatch

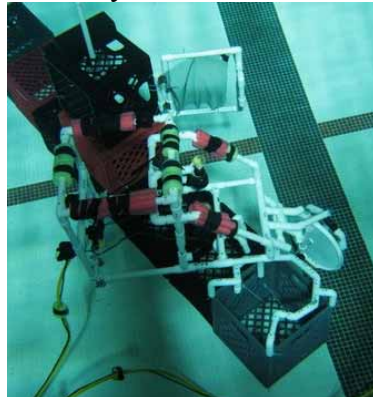

Figure 5: Lifting the hatch

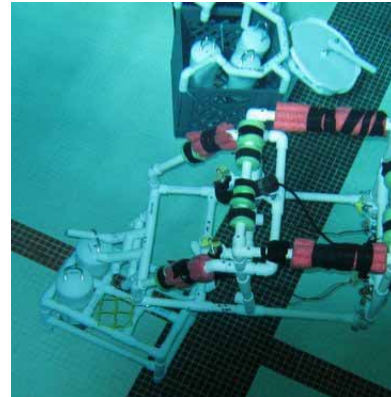

Figure 6: Raising a pod

The last task is getting the airline tee to the submarine. We open the door using the adjustable tee holder. But we have had a lot of problems with the airline tee. We have not yet been able to put it in the pipe so we can flip the valve to turn on the air. We are hoping to fix the problems with the tee before the international competition so that we are able to do all four missions.

Design Rationale and Process

We did not use any computer software for our design because we wanted to do it the old-fashioned way in order to save money. We had \$1,000 for the regional competition which had to cover the ROV, travel to and from Chicago, and food for 15 people. We spent about \$200 on the ROV itself. At first we wanted to make a robotic arm but that would have been too expensive. So we made everything using PVC pipe, nuts, bolts, and floatation.

When we first started to design the shape our ROV we used K'Nex. It was fun for everybody to make a model of what the ROV might look like. There were memorable moments such as figuring out how to make the adjustable tee holder that picks up the ELSS pods and holds the airline tee. We did not make just the ROV but we also made a K'Nex submarine with all of the parts for the actual missions. We used water bottles for the ELSS pods. After we made the K'Nex submarine we practiced with our K'Nex ROV until we could do all of the tasks. It was very enjoyable and helped us get ready for the real missions.

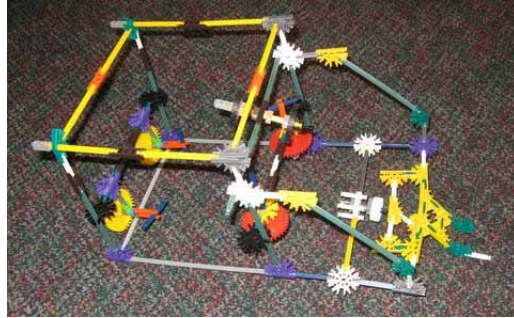

Figure 7: K'Nex model of our ROV

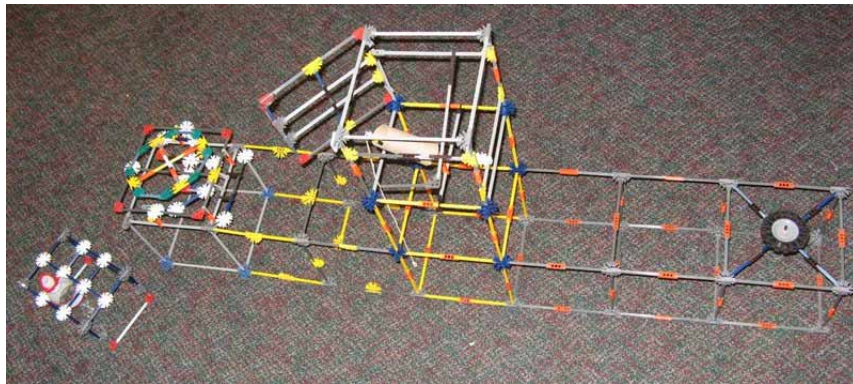

Figure 8: K'Nex model of the submarine

It was mostly teamwork that got us through everything. We worked in teams to build Lil Swag. Raven, Devyn, Asata, and Joe helped design the frame of the ROV. The wiring team consisted of Allen, Gemma, Matthew, John, and Anthony. Everyone helped with the tool design, the buoyancy, the ballast, the poster, and the technical report.

Payload Tools

Transfer skirt: The transfer skirt is made of a 4-in. (10 cm) PVC end cap attached to the ROV with nuts and a bolt. It fits over the escape hatch and covers up all of the red tape. In a real submarine rescue mission, the people would come out of the escape hatch and into the ROV.

Quad turner: The quad turner is a cross with four arms attached to it. The pilot lands the quad turner on the center of escape hatch. Then the pilot turns the ROV in a circle which turns the hatch to unlock it. The quad turner is attached to the ROV with nuts and a bolt. It is on the other end of the cross that holds the transfer skirt to the ROV frame.



Figure 9: Transfer skirt (bottom) and quad turner (top)

Adjustable tee holder: The adjustable tee holder is made out of PVC pipe pieces. It holds the airline in place at a good angle. First we made the design out of K'Nex, but it was hard to build the exact shape with PVC so we had to change it a little bit. We ended up making the tee holder out of two separate pieces. One piece holds the top of the tee and the other piece holds the tee at an angle. It is adjustable so it can hold the tee at different angles. We still need to make a few changes to the holder so the airline tee stays on it and does not float off.

Pod raiser: The pod raiser is made out of a 12-cm length of PVC pipe with foam flotation inside. Before we added the flotation the pods were too heavy to lift. As soon as we added the flotation we were able to lift the pods. The pod raiser is at a small angle so the pods can come off easily when they get to the milk crate.



Figure 10: Adjustable tee holder and pod raiser

Tool Alternative

Mechanical hand: When we were first thinking about the design of our ROV, many of us included a mechanical hand in our sketches. We thought this would allow us to do all of the tasks easily. Having a mechanical hand might have been nice, but instead we used some PVC pipe as a handle and it turned out just fine. This saved us a lot of money.

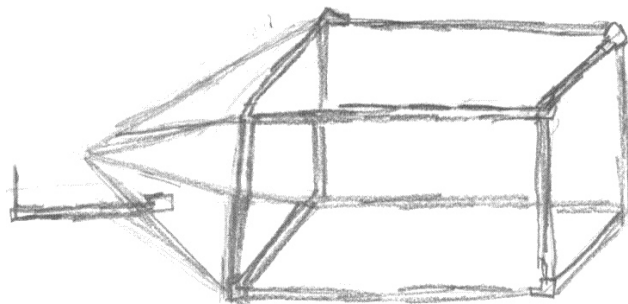

Figure 11: Sketch of an early ROV design

Vehicle Systems and Features

Tether: Our tether is 15 m long. It has eight conductors in it, two for each thruster. Six of the conductors are 22 AWG and two are 18 AWG. Each horizontal thruster is connected to two of the 22 AWG conductors. Each vertical thrusters is connected to one 22 AWG conductor and one 18 AWG conductor. The outer diameter of the tether is 1.1 cm. We added some floatation to the tether since it was not neutrally buoyant. We got the tether from SOSI for the price of shipping.

Thrusters: There are four thrusters on the ROV—two horizontal and two vertical. Each thruster is made out of a bilge pump motor cartridge, a propeller adapter, and a propeller. All of these parts came from Shedd Aquarium’s ROV workshop. Each thruster was already held together with lock-tight so we could not take them apart and put them back together. It would have been expensive to buy new parts just to put them together again so we just used the parts from Shedd.

Camera: The camera is a LCA7700C color underwater camera made by Lights Camera Action. It works well even when there is not a lot of light. It has a nice crisp image and is very sturdy. We got the camera from Shedd Aquarium’s ROV workshop.

Control box: The control box holds all of the wires that attach to the tether and the battery. It has four double pole double throw (DPDT) switches in it. Each switch controls one of the thrusters. There were many people on the wiring team who worked together to build the control box. For the international competition we had to add the camera wiring into the control box. We used a cigarette lighter adapter and soldered it to the main power inside the box.

Frame: The frame is made of ½-in. PVC pipe held together with screws. Using screws instead of glue lets us add or subtract pieces from the frame when we want to make changes.

Buoyancy: For buoyancy we attached foam water noodles to the frame with electrical tape. Every time we made a change to the ROV we had to change the floatation.

Ballast: For the ballast we used nuts and washers. Each piece is not very heavy by itself, so we had to put a lot of them on the back of the ROV to see a difference in how the ROV was floating. We used cable ties to attach the nuts and washers to the ROV frame.



Figure 12: This is what the inside of the control box looked like before we added the camera wires.



Figure 13: Back of the ROV frame, floatation, two thrusters, part of the tether, and ballast on the bottom.

Challenges

During the time we created the ROV we had our fair share of challenges. One of them, for instance, was floatation. The rear of the ROV was floating just perfectly, but the front of the ROV was not balanced. We did everything from putting weights on the back of the ROV to putting floatation on the frame of the ROV. This pattern continued up until the day of the regional competition, where, at the last moment, we added just the right amount of weights to the back of the ROV and it floated with pure excellence.

One of the less important difficulties was that we were supposed to practice at the Notre Dame pool the day before the regional competition, but apparently someone had caught the swine flu there and so we were not allowed to go. We ended up going to the YMCA's pool instead at the last minute. It was not one of our biggest challenges, but it was still a setback.



Figure 14: Nate and Allen wiring the control box

Another setback was wiring the ROV's control box. The wires themselves were fine—it was just really hard getting them into these petite connectors that they were supposed to be in. We tried jamming them in. We kept that up until one of us came up with the idea of twisting them into the caps. And, hey, it worked!

Another minor setback is that our finished control box was extremely hard to use because you had to learn certain combinations to move the ROV left, right, in a circle, and on and on. But then we finally put labels on the controllers and we were all much happier.

The biggest challenge we face before the international competition is that the Boys & Girls Club will be closed from May 22 to June 8 between the end of school and the start of summer. We will not get nearly enough practice during this time, and even if we do get some time, it will only be a limited amount. We will do our best with the time we have.

Troubleshooting Technique

In one of the tasks, the ROV has to open a hatch and deposit six ELSS pods in the submarine. When we went to the regional competition, none of the teams got to this task. We got the hatch open and that was it; we didn't get any of the pods in. Now, after the regional competition, we were trying to get the pods in and we realized it was harder than it looked. We could not quite get the ELSS pod handle on to our adjustable tee holder on the front of the ROV. We tried and tried but it was no use. But then we came up with an incredible idea. One of us cut about 12 cm of PVC pipe and attached it to the adjustable tee holder. Now we could get the ELSS pod handles onto this new pod raiser, but we could not lift them out of the ELSS carousel. So somebody else stuffed some foam flotation into the end of the PVC pipe. After that one of our skilled navigators picked up four pods and put them into the milk crate in only a matter of minutes. This is just one example of the problem solving skills we use for troubleshooting.

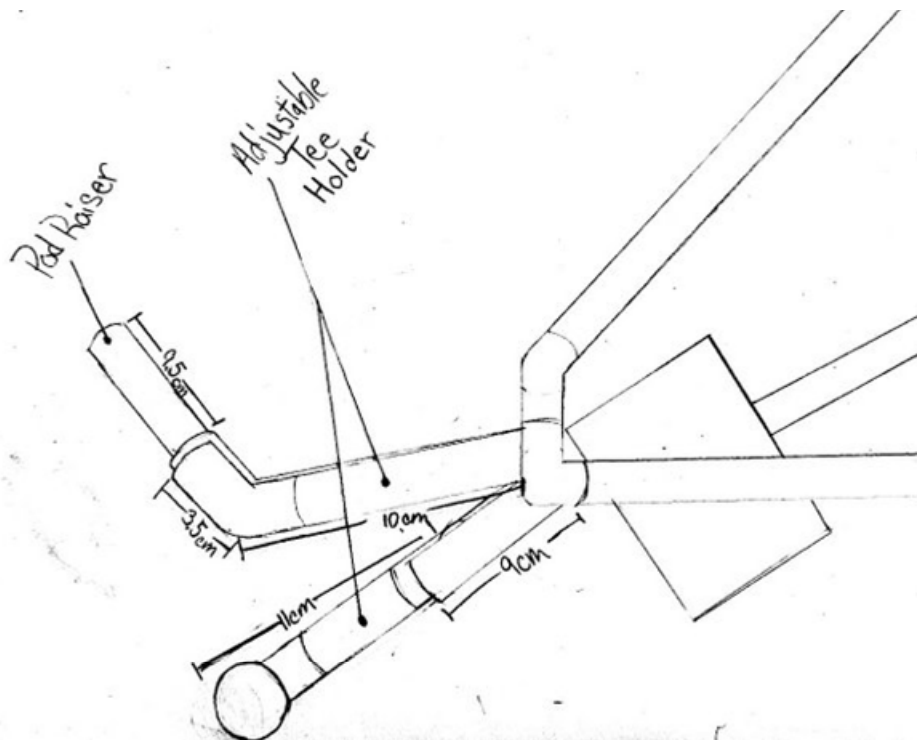

Figure 15: Sketch of pod raiser

Lessons Learned

At the beginning there were about 25 kids on the ROV team. After a few weeks our coaches created a form that kids would have to fill out and a parent would have to sign if their child was serious about being on the team. Less than half of the kids stayed, but now we have a great and dedicated team.

Everyone on the team learned new skills. A lot of people had fun learning how to solder. It is the art of taking a white-hot iron and situating it and some solder on a bunch of wires until some of the solder has melted on to the wires. Many people were eager to play the sport of soldering. It was such fun even if you were terrified about burning yourself while you were doing it.

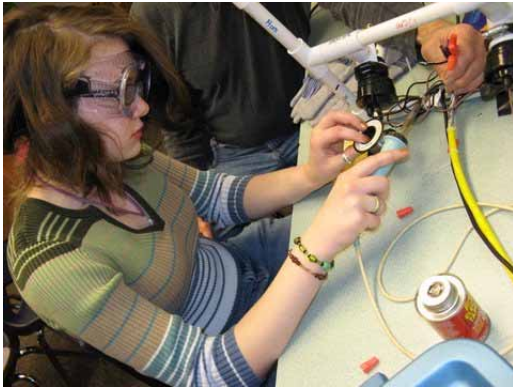

Figure 16: Gemma soldering the tether wires to the thruster wires



Figure 17: The poolside team works together to set up the ROV at the regional competition

We also learned that teamwork is essential when you are working with others. We all had our fair share of disagreements, but it didn't stop us from winning the regional competition. The poolside team works well together. No complaints there except that our two drivers are fighting it out about who is the true pilot and who is the co-pilot, but that is mostly just amusing. When we are actually at the competition we do not argue but instead work together really well. It just goes to show that people can get along if they try.

Future Improvements

It appears that our ROV does not have a lot wrong with it. And that is true. The control box works just fine; our camera has good vision; and a lot of other things about the ROV are grand. Our only real problem is that the tee keeps plummeting off the ROV. We have tried a lot of different things to make the tee stay on, and so far nothing has worked. We tried clay; we tried lessening the amount of string we deposit into the water; and we tried putting more string into the water. So far all of these endeavors have been unsuccessful. We are still trying to figure out what we could do differently, but we have few ideas. We might try using incredibly weak magnets on all three sides of the tee or using a little Velcro on the heart of the tee, but we are still undecided. We hope to try these things at our next pool session.

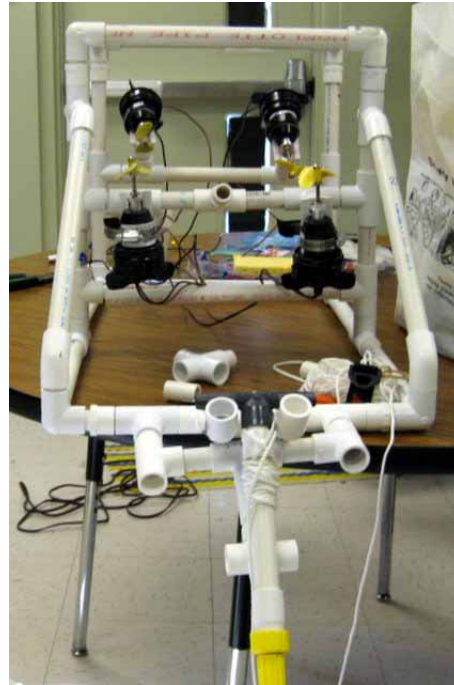

Figure 18: An early version of the ROV's adjustable tee holder holding the tee. It did not have problems on dry land!

Another problem is that the tee's string keeps getting caught in the propellers and, let me tell you, it is not fun unwinding the string. It keeps happening over and over again no matter how much string we hold back. We tried to come up with a few different ways to solve that problem, such as situating the string between two of our floatation devices, but none of them have worked exceptionally well. During our last pool session, one team member came up with the idea of planting the string under the ROV so there is less of a chance of the catastrophe with the propellers. We have not tried this experiment yet, but I can tell you that we are all waiting with bated breath to see what will happen.

ELSS Pods in the Real World

Emergency Life Support Stores (ELSS) pods are used to help submarines that are in trouble. Perry Slingsby Systems is an organization that builds ELSS pods. Each ELSS pod is a cylinder with a removable top and a lifting handle. ELSS pods are placed in a submarine's hatch to deliver emergency supplies to the crew and help them survive until the submarine is fully rescued. The ELSS pods are slightly positively buoyant in seawater. This allows the pods to be delivered by a diver in an atmospheric diving suit, a remotely operated vehicle (ROV), or a rescue submersible.

ODIM Brooke Ocean is an organization that has designed a system to get ELSS pods close to a submarine. The system is called the Launch and Recovery System (LARS). When a submarine gets damaged, the crew would call for help. When rescuers get the call, a ship with a LARS on board would go to the scene and would lower ELSS pods to the sea floor near the submarine.

Our ROV relates to this because when the LARS drops the ELSS pods on the sea floor, an ROV or a person goes to get them. In the MATE competition we have to use our ROV to take ELSS pods to the submarine. The pods are just sitting next to the submarine, but in the real world, they would have gotten there by being dropped off by a LARS or some other system.



Figure 19: ODIM Brooke Ocean's LARS gets ready to launch a set of ELSS pods.



Figure 20: Close-up view of ELSS pods before they are launched by the LARS

Sources

"Emergency Life Support Stores (ELSS)" Emergency Life Support Stores (ELSS). The Perry Slingsby Systems. 05/23/09 <http://www.perryslingsbysystems.com/assets/pdf/datasheets/controlls_and_miscellaneous/ELSS_Pods.pdf>.

"Submarine Pod Posting System for the Canadian Navy" ELSS Pod Posting. 07/26/06. ODIM Brooke Ocean. 04/29/09 <<http://www.brooke-ocean.com/elss-01.html>>.

Reflections



Valerie: I accomplished a lot of things during this competition. I designed some of the parts for our ROV. I helped put the poster together by gluing the pictures and the captions. I also helped cut the PVC pipe for the ROV and put the frame together. I helped our team win, but I wish that I could have helped even more.



Joseph: I learned how to work as a team. Also, I got to help the team win the regional. Plus I made more friends. I had a lot of fun doing this competition.



Gemma: I accomplished many things. For instance, I accomplished how to not to scream and point, “The ROV goes that way!” I proficiently learned how to solder, which is amazing. I made my way from knowing zip about robots to learning how to wire an underwater robot. All in all I loved it!



Anthony: I learned how to solder for the ROV competition. Also I learned how to wire wires and crimp the parts of the wires for the control box. It was fun learning all these things.



John: I learned about all of the tasks we had to do for the MATE ROV competition. I did a lot of the drilling on the ROV, too. Being on the ROV team was a lot of fun.



Asata: My biggest accomplishment was making the adjustable tee holder. At first I was just playing around trying to figure out what to do. It was hard and I was hoping that an idea would just pop in my head. It was not as easy as I thought, but luckily I figured it out.



Matthew: The most rewarding part of being on the team was getting to work on the ROV, learning about the tasks for the competition, and working with our coaches. I also had a lot of fun.



Allen: I have accomplished many things during the ROV competition. I got better at working together with everyone on the team. I also learned how to use the control box for Lil Swag. One day at Notre Dame everyone was trying to land the transfer skirt on the escape hatch. When I got the controls, I aimed carefully and just did it. Ever since then I’ve been in charge of that part of the mission.

Reflections (continued)



Nate: I joined this competition to have fun and I have had fun! I learned how to work with the wiring and the controls. I'm probably what you would call the tech man for the team.



Curtis: I helped build the ROV and helped add buoyancy to it so it would float right in the water. I thought we were going to lose the regional competition, but when we won, it felt great.



Raven: Being on the ROV team taught me how to work together in a group of people and how to depend on others to complete tasks.



Devyn: I have accomplished a lot of things on the ROV team at the Boys & Girls Club. I got to work with other people and create a wonderful underwater robot. I have never done anything like this before and it was something new and fun for me. I learned how to make the airline stay underwater and not float. I got to help model and build the ROV with PVC pipe. I also learned about the different parts of the ROV and how to do the tether.

Acknowledgements

We would like to proudly thank all the people and organizations that helped us get to this international competition.

- Notre Dame University let us use their pool for free on Thursdays to test our ROV in the water.
- We would like to thank Martin's Super Market for giving us free milk crates to use for our version of the submarine.
- Thanks to Ace Hardware for giving us a 10% discount on all of the supplies we purchased from the store.
- We would like to thank MATE for letting us compete in this competition and sponsoring all of the teams that are competing.
- Re-Store gave us an excellent discount on all of the supplies we bought and that helped us out a lot with the amount of money we spent.
- Jerry Nurenborg taught us how solder, how to wire the control box, and how to hook up the camera to the control box.
- We would also like to thank SOSI for giving us a 15 m tether and only charging us the price of shipping.
- Thanks to Shedd Aquarium for giving us a camera, thrusters, 12-V battery, DVD player, and support.
- Thank you to ETHOS for letting us borrow a tub to use for testing the buoyancy of our ROV.
- Thanks to the Union League Boys & Girls Club for letting us spend the night for free when we were in the Chicago for the regional competition.
- Thank you to the Purdue University IEEE ROV Team for giving us advice at the regional competition and for coming to South Bend to help out at one of our pool practices.
- We would like to thank our own Boys & Girls Club of St. Joseph County for supporting and funding us.
- Most of all we would like to thank Ms. Lucinda and Mrs. Laura for being such good helpers to us and letting us compete in this competition.

Thank you to the individuals who donated money for our trip to the international competition:

- Charles Pittman
- Duke Jones
- Eileen and Bill Evans
- Frank Perri
- Ida Watson
- Jacqui Walton
- John Axelberg
- John Phair
- Jose Alvarez
- Julie Mark
- Michael Knight
- Michael and Stephanie Pries
- Paul Meyer
- Steve Watts
- Tom Cassidy

Thank you to the organizations that donated money for us to go to the international competition:

- Boys & Girls Clubs of St. Joseph County
- University of Notre Dame College of Engineering

Appendix 1: Budget

**Boys & Girls Clubs of St. Joseph County
Aquatic Swag Remotely Operated Vehicle (ROV) Team**

Budget from January 29, 2009 through May 27, 2009

Items for ROV that were donated or obtained at Shedd workshop

Item Description	Vendor/Donor	Unit Price	Quantity	Total Price	Comments
8.5-in. portable DVD player	Best Buy/Shedd	\$159.00	1	\$159.00	viewing monitor for camera
1-1/2-in. PVC tee	Ferguson Supply/Shedd	\$0.46	5	\$2.30	motor and camera mounts for ROV
No. 20 hose clamp 1-3/4 x 13/16 in.	Ferguson Supply/Shedd	\$0.82	1	\$0.82	hose clamp for camera
motor propeller adapters	Happy Hobby/Shedd	\$4.29	4	\$17.16	adapters for propellers
motor propellers	Happy Hobby/Shedd	\$1.15	4	\$4.60	propellers for motors
RCA to BNC adaptor	Jameco Electronics/Shedd	\$1.59	1	\$1.59	camera to monitor adaptor
solder	Jerry Nurenborg	donated		donated	attach tether wires to motors
LCA7700C color underwater camera	Lights Camera Action/Shedd	\$425.00	1	\$425.00	camera for ROV
#36 hose clamps	Lowes/Shedd	\$1.09	4	\$4.36	attach motors to PVC on ROV
10-24 stainless steel nut, 10-pack	Lowes/Shedd	\$3.80	1	\$3.80	attach props to motors
10-24 stainless steel screws, 5-pack	Lowes/Shedd	\$2.45	1	\$2.45	attach props to motors
10-24 stainless steel split lock washers, 10-pack	Lowes/Shedd	\$2.14	1	\$2.14	attach props to motors
12V DC accessory outlet	Radioshack/Jerry Nurenborg	\$6.99	1	\$6.99	attach camera connector to control box wiring
12V cigarette lighter Y adaptor/splitter	Radioshack/Shedd	\$8.99	1	\$8.99	needed for camera and monitor power
8' 12V cigarette lighter power cord	Radioshack/Shedd	\$7.99	1	\$7.99	camera power cable
fuse holder	Radioshack/SRF, Inc.	\$2.49	1	\$2.49	ROV protection
jump start battery	Sam's Club/Shedd	\$44.88	1	\$44.88	power supply
bilge pump motor cartridges	West Marine/Shedd	\$12.99	4	\$51.96	motors for ROV
TOTAL DONATED FOR ROV:				\$746.52	

Appendix 1: Budget (continued)

Items purchased for ROV

Item Description	Vendor	Unit Price	Quantity	Total Price	Comments
bag of 100 1/2-in. sheet metal screws	Ace	\$3.99	1	\$3.99	ROV frame
box of 100 1/4-in. hex nuts	Ace	\$3.99	1	\$3.99	ballast
box of 100 1/4-in. washers	Ace	\$10.99	1	\$10.99	ballast
liquid electrical tape	Ace	\$8.99	1	\$8.99	waterproof underwater connections
package of 10-12G splice crimps	Ace	\$2.99	1	\$2.99	for splicing and attaching wires
package of 18-22G female disconnect crimps	Ace	\$2.79	1	\$2.79	attach tether wires to switches
water noodle	Dollar Tree	\$1.00	4	\$4.00	floatation
4-in. PVC cap	Home Depot	\$1.55	1	\$1.55	ROV payload tool
1/2-in. PVC 90deg elbow w/side out	Lowe's	\$1.13	10	\$11.30	ROV frame
package of 10-12G female disconnect crimps	Lowe's	\$3.20	1	\$3.20	attach power wires to switches
10-ft length of 1/2-in. PVC pipe	Lowe's	\$1.22	2	\$2.44	ROV frame and payload tools
10-pack 1/2-in PVC 45deg elbow	Lowe's	\$4.23	2	\$8.46	ROV frame
10-pack 1/2-in. PVC 90deg elbow	Lowe's	\$1.84	2	\$3.68	ROV frame
10-pack 1/2-in. PVC male adapter	Lowe's	\$2.97	1	\$2.97	ROV frame
500 assorted cable ties	Lowe's	\$6.97	1	\$6.97	general construction
black electrical tape	Lowe's	\$1.87	3	\$5.61	general construction
wires and miscellaneous electrical supplies	Lowe's	\$20.00	1	\$20.00	control box wiring
miscellaneous hardware	Lowe's	\$10.00	1	\$10.00	ROV frame
1/2-in. PVC cap	Menards	\$0.23	4	\$0.92	ROV frame and payload tools
1/2-in. PVC cross	Menards	\$0.87	4	\$3.48	ROV frame
10-pack 1/2-in. PVC coupling	Menards	\$1.28	2	\$2.56	ROV frame
10-pack 1/2-in. PVC tee	Menards	\$1.84	4	\$7.36	ROV frame and payload tools
package of 5-A fuses	Menards	\$1.77	1	\$1.77	camera protection
20A DPDT switch	Radioshack	\$4.59	4	\$18.36	controls for motors
2-pack of banana plugs	Radioshack	\$5.49	1	\$5.49	for attaching ROV to battery
package of 4 20-A fuses	Radioshack	\$1.99	1	\$1.99	ROV protection
project box, 7 in. x 5 in. x 3 in.	Radioshack	\$5.99	1	\$5.99	control box
1 ft 1/2-in. PVC	ReStore	\$0.10	20	\$2.00	ROV frame
50-ft tether with eight conductors	SOSI	\$25.00	1	\$25.00	SOSI donated tether; just paid shipping

Subtotal: \$188.84

Sales tax minus discount from Ace: \$7.97

TOTAL PURCHASED FOR ROV: \$196.81

Appendix 1: Budget (continued)

Other costs related to regional ROV competition

Item Description	Vendor/Donor	Unit Price	Quantity	Total Price	Comments
2-pack 5/64-in. drill bit	Ace	\$3.79	1	\$3.79	general construction
5/16-in. drill bit	Ace	\$4.49	1	\$4.49	general construction
drain/fill waterbed kit	Ace	\$6.99	1	\$6.99	for filling test tub
safety goggles	Ace	\$3.29	2	\$6.58	safety
stripper/crimper tool	Ace	\$7.49	1	\$7.49	general construction
transportation and food in Chicago May 1-2	BGC van and cash	\$460.00	1	\$460.00	cost for tolls, snacks, dinner on Friday night, dinner on Saturday night, and parking at Shedd
PVC pipe cutters	Ferguson Supply/Shedd	\$29.32	1	\$29.32	general construction
pizza dinner after pool session	Little Caesars	\$71.36	1	\$71.36	Navarre Club paid \$35
strip/cut/combo tool	Lowes	\$11.97	1	\$11.97	general construction
1-hour test sessions at Notre Dame pool	Notre Dame	donated		donated	one hour per week donated for pool practice sessions
12-pack Sharpies	OfficeMax	\$9.79	1	\$9.79	poster for regional competition
6" diagonal pliers	ReStore	\$2.49	1	\$2.49	general construction
foam display board	Staples	\$15.49	1	\$15.49	poster for regional competition
lodging in Chicago on May 1	Union League BGC	donated		donated	space donated by Boys & Girls Club
team t-shirts	VistaPrint	\$8.04	20	\$160.86	Aquatic Swag team shirts
1-hour test session at YMCA pool on April 30	YMCA of Michiana	\$20.00	1	\$20.00	last-minute switch to Y because of swine flu scare at Notre Dame
2-hour test session at YMCA pool on April 26	YMCA of Michiana	\$150.00	1	\$150.00	Navarre Club paid full \$150 cost
room rental for pizza dinner after pool session	YMCA of Michiana	\$75.00	1	\$75.00	Navarre Club paid full \$75 cost

Subtotal: \$1,035.62

Sales tax: \$4.84

Paid for by Navarre Club or donated by Shedd: -\$289.32

TOTAL OTHER COSTS RELATED TO REGIONAL: \$751.14

Total cost to build ROV and compete in regional competition:	\$947.95
Total budget supplied by Boys & Girls Clubs of St. Joseph County:	\$1,000.00
BUDGET BALANCE: \$52.05	

* Final costs to attend the international competition are still being determined. We estimate that it will cost about \$12,000 and are trying to raise that amount.

Appendix 2: ROV Statistics

Length: 59 cm

Width: 38 cm

Height: 35 cm

Mass: 5.4 kg out of the water

Camera: LCA7700C color underwater camera made by Lights Camera Action (LCA)

Tether: 15 m tether made by Sound Ocean Systems, Inc. (SOSI)

Number of conductors in tether: 8 (six 22 AWG and two 18 AWG)

Number of thrusters: 4 (two horizontal and two vertical)

Forward speed: 23 cm/s

ROV Sketch

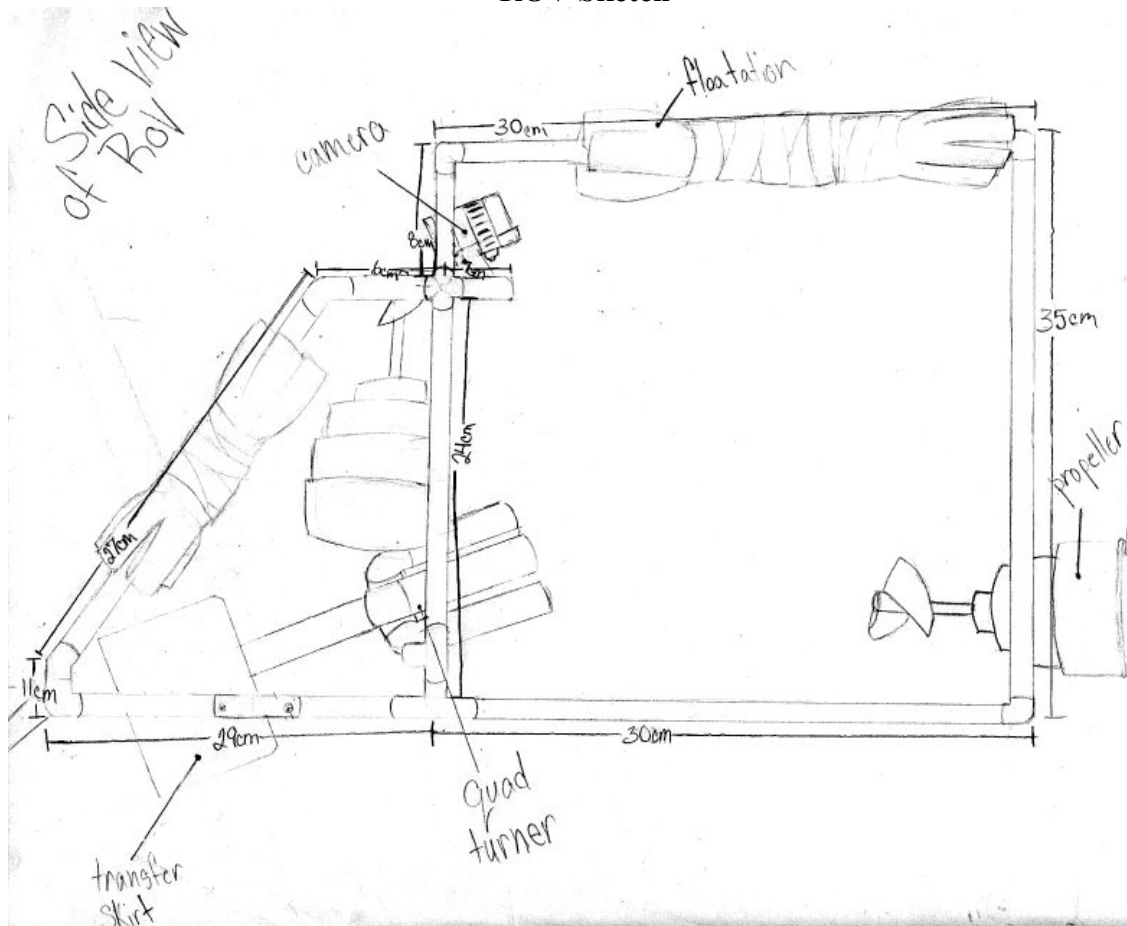

* See page 7 of this report for a sketch of the front of the ROV that includes the adjustable tee holder and the pod raiser.

Appendix 3: Control Box Electrical Schematic

