



MATE
MARINE
ADVANCED
TECHNOLOGY
EDUCATION
CENTER



2009 International MATE ROV Competition



Dyce Academy

ROV Design and Build Report

Scotland Regional Competition
4th April 2009
RUFUS MkII

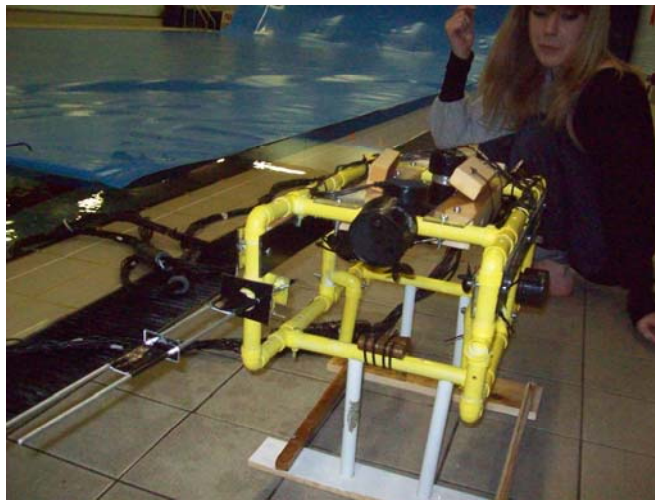

Team members:

Liam Jones
Matthew MacGregor
Ellen Mitchell
Lisa Simpson
Amy Frost
Tony Strachan
Lewis Copland
Andrew Holt
Philip Webster
Eilidh Hunter

Mentors:

Dougie Simpson
Páiraic McLoughney

Table of Contents

Table of Contents.....	2
Abstract.....	3
Completed ROV Photographs.....	5
Cost Tracking spreadsheet.....	6
Electrical Schematic.....	7
Design Rationale.....	8
Overall concept.....	8
Propulsion.....	8
Buoyancy.....	8
Frame.....	8
Umbilical.....	8/9
Control.....	9
Camera.....	9
Design Challenge.....	11
Troubleshooting Techniques.....	12
Lesson Learned.....	12
Future Improvements.....	12
Submarine Rescue System - in action in the real world.....	13
Reflections.....	13
References.....	14
Acknowledgements.....	14

Abstract

Having learnt much from last year's competition and taking many positives and ideas from it, the team knew the right direction to proceed with RUFUS MkII. By spending more time pool testing and basing the structure of RUFUS MkII around the rescue tasks, preparation is certainly much better than last year, as each person knew his/her strengths and stuck to them, thus allowing production of a much more efficient ROV, both dynamically and aesthetically. The aim this year, was to build an ROV capable of demonstrating technical flair and prowess and being efficient enough to sufficiently carry out the tasks provided.

The rough frame idea for RUFUS MkII, it was deemed, was required to be much smaller due to the nature of some of the tasks – i.e. opening the hatch. The ideas for the frame and assembly respectively were drawn up on Autodesk Inventor Professional 11 – a graphics software programme – for ideas on shape, structure and dimensions then assembled in accordance to the idealised solution. Each task was solved as its own, having a claw/arm at the front to carry down the air hose, a skirt at the bottom for escape from the submarine, and a pipe at the front to both open the hatch and lift the weights out.

The finished RUFUS MkII seems relatively simple technologically, this being completely purposeful, as with a design such as this there are virtually no unsolvable problems that could come up at poolside, which would be a disaster. Despite this simplicity RUFUS MkII is an effective and capable ROV, able to carry out all the tasks effectively and well.

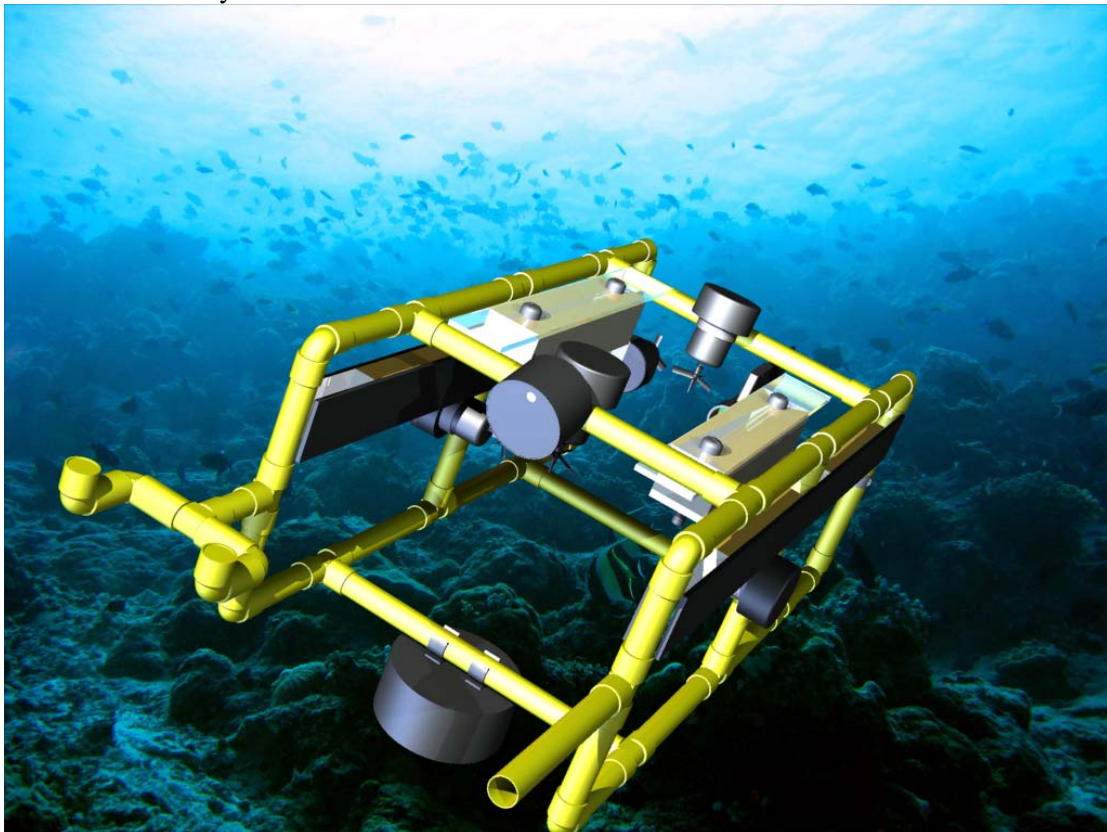

A full render of RUFUS MkII, under the sea, done using Photoshop

Completed ROV Photographs

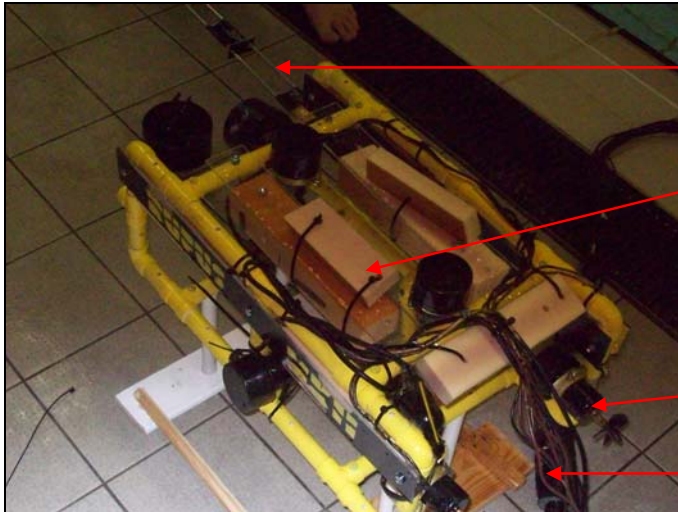

Claw

Buoyancy

Motor /pump

Umbilical

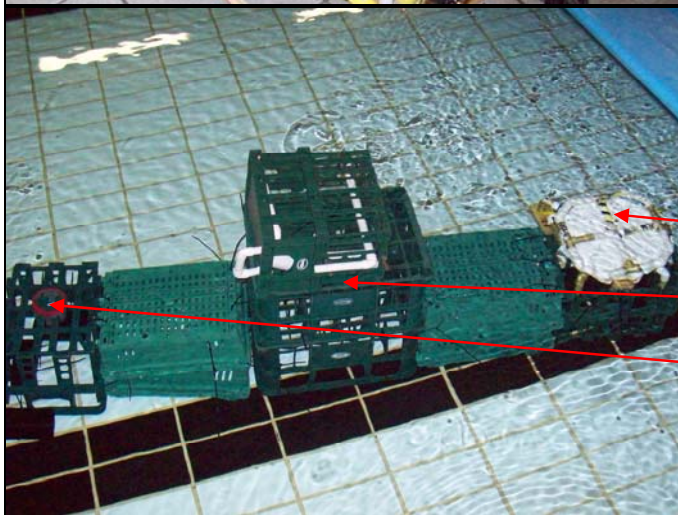

Hatch

Valve

Skirt

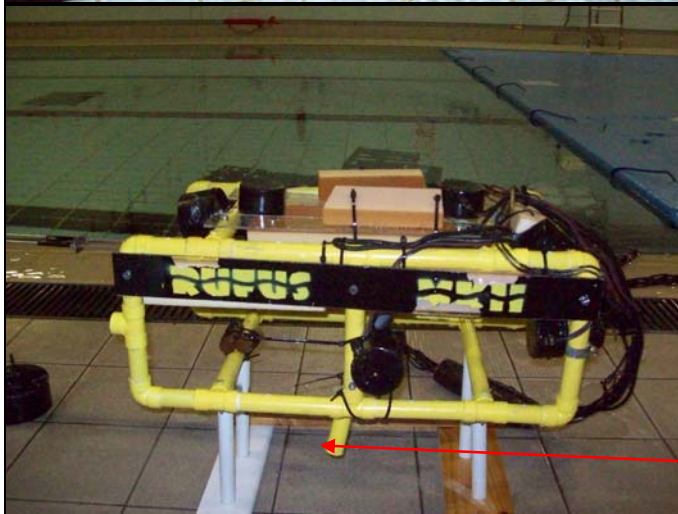

'Legs' to open hatch

Cost Tracking spreadsheet

<i>System</i>	<i>Subunits</i>	<i>Qty</i>	<i>Unit cost</i>	<i>Subtotals</i>	<i>Total</i>
<i>Propulsion</i>					
	Motors	4	£15	£60	
	Propellers	6	£0.50	£3	
					£63
<i>Buoyancy</i>					
	Buoyancy Block	1	Salvaged	N/A	
					N/A
<i>Frame</i>					
	Tubing	2	£3.68	£6.36	
	T Joins	25	£1.58	£39.50	
	Joins	20	£0.94	£18.80	
	Spray-paint	3	£3.00	£9.00	
					£64.66
<i>Umbilical</i>					
	Cabling		Salvaged	N/A	
	Buoys		Salvaged	N/A	
					N/A
<i>Control</i>					
	Switches	8	£0.62	£4.96	
	Cabling		Salvaged	N/A	
					£4.96
<i>Camera</i>					
	Camera	1	Salvaged	N/A	
	New Camera	1	Free	N/A	
					N/A
<i>Overall Total</i>					£132.62

- Original budget was £250, so the team made a total saving of £117.38.
- ‘Salvaged’ refers to any item reused from last year.

Electrical Schematic

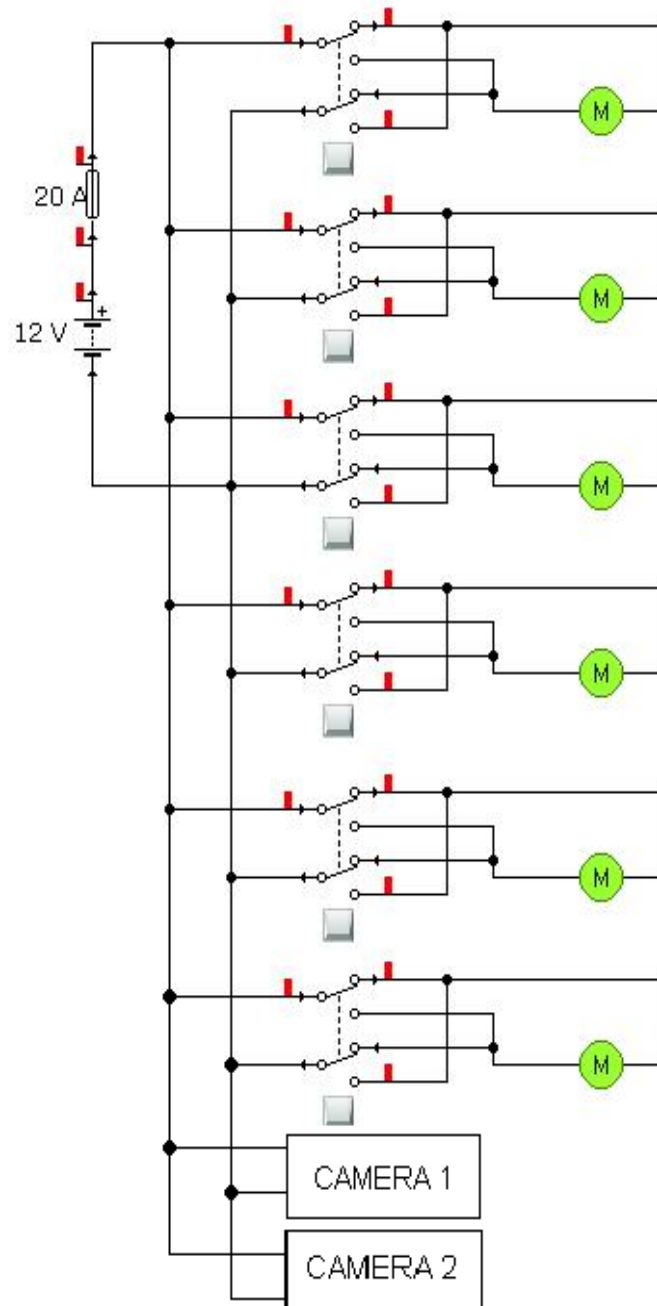

Design Rationale

Overall concept

The team started this year with a good idea as to how to improve and set about creating a 'Lessons learned from last year' sheet and then a project plan for this year, evaluating the missions and creating rough ideas as to how to solve them. Sub-divisional groups were created with regards to each specific person's strengths. It was decided that the frame needed to be much more compact than the original RUFUS's, due to the nature of this year's tasks – i.e. rotating around an axis to open the hatch. It was a good idea to stick to the same general design as last year, as this way it was possible to draw from experience and salvage much of the same equipment, for example, bilge pump, umbilical, propellers etc. Each part for RUFUS MkII was assembled using Autodesk Inventor 11 before being equipped to the actual ROV, giving an idea of what the finished product would look like as well as highlighting any potential problems with that design. A mock submarine, as would be used on competition day was built and utilised during pool testing, proving very useful in both solving the tasks, and, at the very least, providing information as to how we may go about them. A major design theme was to keep RUFUS MkII as simple, yet efficient as possible, thus maximising performance and minimising risk of fatal damage on competition day.

Propulsion

The bilge pumps used were of the same variety as last year, 1100gph displacement. The only modifications made to them was that the impellers originally supplied were removed and replaced with propellers, for a more direct substantial power through the water. The forward/backwards pumps are placed adjacent to each other at each rear vertical rear pipe, the lateral pumps placed inwards and facing each other on each mid pipe, and the up/down pumps placed propeller upwards with one on each lateral top pipe. This positioning was chosen as none of these pumps get in the way of any equipment necessary to completing the tasks, i.e. the skirt, yet allow the ROV to maintain a relatively good centre of gravity. With this positioning, however, stability was an issue as RUFUS MkII was now very top heavy. It was considered solving this problem by moving the up/down pumps to the bottom lateral pipes, however with this setup they would have gotten in the way of opening the hatch and the skirt, so we instead added ballast to stabilise RUFUS MkII under the water. The pumps run off a 12v D/C battery.

Buoyancy

The amount of buoyancy required for the ROV as a whole was derived from the amount necessary for each component as a whole. This was done using the following steps:

- Weigh part on scales

- Fill plastic tub to brim with water and weigh
- Put object in tub until water overflows then remove
- Reweigh tub of water
- Subtract this from previous weight
- Subtract weight of object from weight displaced
- This is equal to buoyancy force

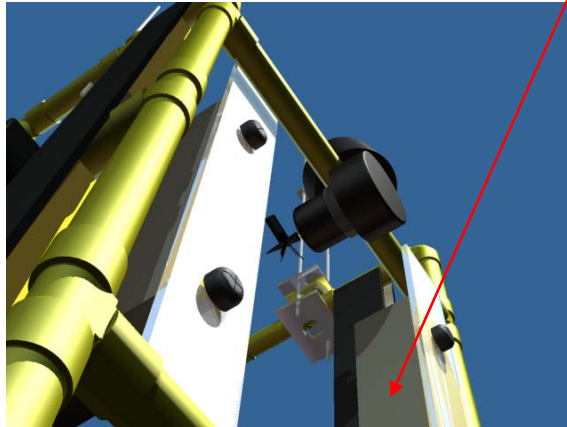

The overall buoyancy force was calculated to be +133newtons.

However when the ROV was tested in the pool, the buoyancy was found to be slightly different to the calculated amount, so it became a matter of fine tuning trial and error. Once this was problem was solved however the ROV ran fine, being slightly negatively buoyant but easy to bring up and down nonetheless.

The type of buoyancy block used was 'Syntactic buoyancy block', as it is very efficient and light enough so as not to compromise the ROV too much.

Frame

The frame for RUFUS MkII is notably smaller than that of the original RUFUS's that taken to the competition last year. This is due to the fact last year's frame was very large, and would be an impractical size given the fact that space may be short when it

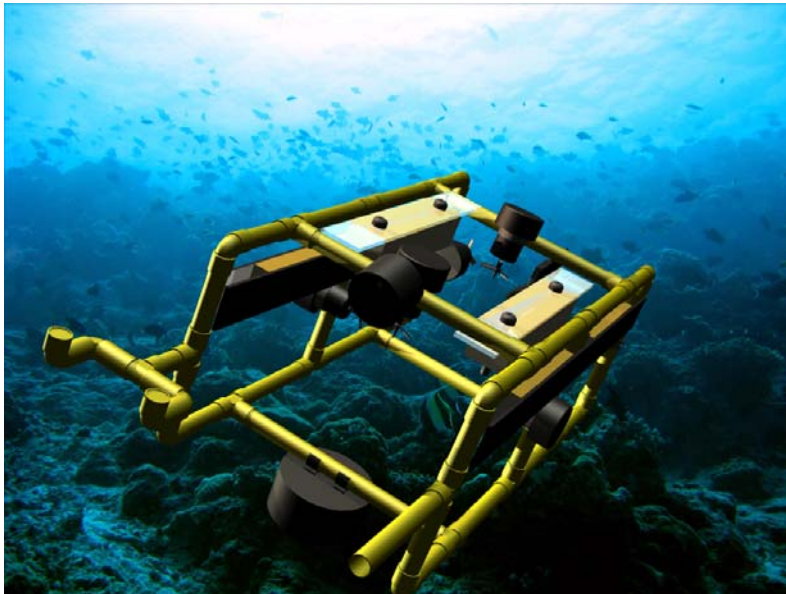

comes to rotating and opening the hatch. Indeed it is a piece of pipe protruding from the front of the frame we shall use to open the hatch and lift the weights out, effectively hooking them and carrying them out with it. The frame is made of 21mm diameter PVC tubing, as it is light, cheap and

easy to acquire. These tubes are held together with standard 45 degree and t joins, as should there be any problems with the frame, these are easy to replace and repair. Aluminium tubing was considered as an option, as the tubing would be thinner and have a much higher tensile strength. However due to cost and ease of repair the idea was discarded.

The frame is drilled to flood it with water and create initial negative buoyancy, and add mass – thus stability. This negative buoyancy countered by the buoyancy blocks which counteract this. The shape of the frame is purely functional; each pole taking into account of what piece of equipment needs to go on it, thus helping prevent unnecessary design flaws and/or problems.

As a finishing touch, the frame was sprayed yellow.

Umbilical

As all the bilge pumps are hardwired to toggle switches, the umbilical is of considerable width, though much of it is salvaged from last year. A similar principal was followed of taking each cable leading from pump to switch, bundling them together, and securing tightly with cable ties. At this point the umbilical was tidier and neater but very heavy. To counteract this, several buoys were added at interval along it thus making it positively buoyant most of the way along and concurrently much easier for RUFUS MkII to propel himself through the water. The umbilical is long enough to suit the requirements of the task, yet short enough not to suffer any noticeable voltage drop across it.

Control

To control RUFUS MkII through the water we have 6 bilge pumps in place, hardwired to toggle switched cased in what we regard as one of our ‘piece de la resistance’ features – the control box. Hardwiring was chosen over more complicated microcontroller/joystick control due to the greatly decreased chance of any electrical problems and the fact that this setup proved both reliable and effective last year. Each switch is of digital control function, which is to say the motor is either ‘on’ or ‘off’ and spinning in either the clockwise or anti-clockwise direction. In this setup we have chosen technical functionality over anything else, using experience of last year to guide us. The control box was fashioned out of the box our newest camera came in. Holes were drilled for the banana plugs to be connected to the umbilical - the plugs being connected to the switches inside. We have kept the LCD monitor which the camera connects to above the switching in the box, allowing us to more easily control the ROV and see what it is doing at the same time.

Camera

The cameras used are both the one kindly supplied to all teams, as well as the one that Kongsberg, also generously, allowed the team to construct and keep last year. This meant travelling to Kongsberg in free time, potting, assembling and then waterproofing the cameras before testing, with only a small degree of assistance. This gave valuable experience that would otherwise not have been gained from a shop bought camera. Additionally this means that camera was a cost free area. Both are positioned from top lateral beams, one front one rear, however due to positioning it became a problem to view the claw that enables us to carry the air hose down. This was solved by positioning a mirror in one of the camera's views, allowing us to see a clear reflection of the claw and where it is at all times.

Design Challenge

The process of building RUFUS MkII was relatively unhindered, with little in the way of fluctuation from task or building problems. However it was found, similarly to last year that getting the ROV to the correct level of buoyancy was quite a challenge. Calculations were carried out to give a good rough idea of how much would be required, but when it came to pool testing it became clear that although much better initially than the original RUFUS, there was much tweaking to do. When the correct level of buoyancy was found, there was the challenge of then putting this on RUFUS MkII without ruining the centre of gravity. To counter this, mirror strips were painted

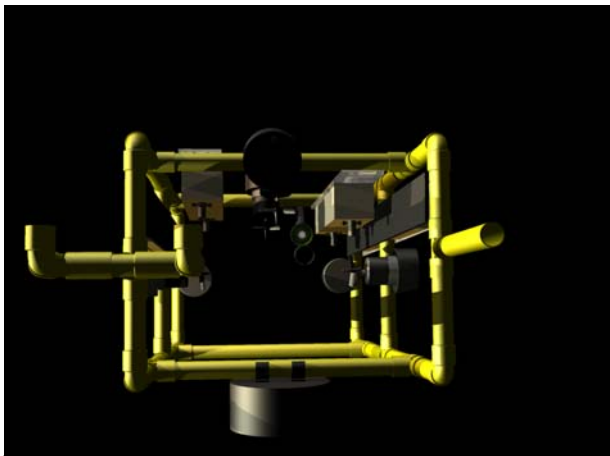

A frontal render of RUFUS MkII, done on Autodesk

black, the buoyancy blocks placed between two adjacent strips of this and bolted in place. Bolts were chosen as they are light, easy to use, and can be quickly moved around and changed should any problem arise. When tested, the ROV now worked as planned, being powerful, efficient, and simple enough so that there was no problem in tweaking any minor gremlins. This left a great feeling of confidence and optimism.

Troubleshooting Techniques

As a team being constructed of friends it was a given that working both constructively and well together, helping one another overcome any difficulties on both the technical and practical side of the ROV equation would not be an issue. Whenever a minor snag or problem did occur, it was collectively dealt with well and as a team. When time was short, spare time was taken out to go and work on RUFUS MkII, or when uncertainties arose with positioning of pieces it was modelled on the computer model beforehand. When it came to some practical aspects it was just a case of trying and testing, chopping and changing. The team did not criticise or linger on any problems but dealt with them swiftly and moved on – i.e. the switches were initially wired up wrong, yet we quickly rectified this problem. As a whole it was an efficient, friendly environment at all times, the ROV reflecting this and the effort that was put in.

Lesson Learned

This year it was learned that pool testing and evaluation is key to the success of the ROV. Last year constant revisions had to be made and buoyancy removed at poolside on competition day, due to this lack of pool testing. This should most certainly not be the case this year.

As well as this the team benefited from a smaller, more mature group this year, giving a more efficient working capacity.

Also learned was how to structure the project to a time limit. As of last year additions were being made to the original RUFUS the morning of the competition. This year a plan was created and finished on schedule, allowing time to test, modify and solve any potential problems. Thus it was found that having a structure to RUFUS MkII is critical to success.

Besides these each member of the team stuck to their respective strengths, allowing an ROV of maximum competence, yet shared what they were doing with each other member to ensure vital communication throughout.

Future Improvements

There aren't a huge amount of regrets with regard to RUFUS MkII, though there are a few things that could be improved upon.

For a start, ditching the more simple hardwired control circuit in favour of a microcontroller/joystick control system is definitely something to consider, as it would be both technically impressive and easy to pilot RUFUS with. The idea was not chosen this year as it required a lot of research and time to perfect and get right, as well as getting in a lot of electrical components we did not have and were hard to source. However next year it is aimed to have them, resolving the above issues with research, time and an even higher level of programming ability within the team.

As well as the microcontroller/joystick system, improvements can be made to the computer model we have, with loads, stresses and a multitude of other forces worked out using the Autodesk package's 'Dynamic simulation' mode. This would save both practical time and effort, generally making the build process a little easier when it comes to things such as buoyancy for example. The feature was not used this year due to a restriction of time and the sheer amount there was to learn with regards to use it. However next year, with this time and with Advanced Higher Graphic Communication, it should be employed as a solution to some of our problems.

We may also consider different frame materials next year, rather than the PVC piping. If metal tubes were used instead the frame would both be more compact and stronger, though much harder to fix or modify. If next years' task calls for any such solution it may be considered.

Submarine Rescue System - in action in the real world



The LR5 Submersible Submarine Rescue Vehicle is an ROV employed by the Royal Navy and based near Glasgow. It has the capacity to carry up to 15 people to safety at an air pressure of 5 bar, and draws parallels to our ROV in that it is designed to take stranded crew

from stranded submarines back to the surface, employing a mating skirt to do so – indeed in August 2005 it rescued 7 Russian crew members from the Priz submarine which had become entangled in fishing nets.



Of course at 9.2m long and weighing 21.5 tonnes it's significantly larger than RUFUS MkII, as of course his mission is scaled down from the real ones LR5 tackles – being ready to move to any corner of the world on a 12 hour basis. The SSRV carries 3 crew members down at a time – a pilot, co pilot and system operator. As well as this, LR5 is equipped with a multitude of tools to deal with a variety of rescue situations, such as wire cutters, a claw (more advanced than the one of RUFUS MkII, but for similar purpose) and rope cutters. It operates off two 6000 watt motors and is capable of diving to 500m.

Reflections

The experience as a whole has been very positive. Every member of the team has worked extremely hard and gave it everything to try and ensure a win this year. It is felt great deal has been learnt from building RUFUS MkII, utilising these new skills effectively to aid the build process, having good fun and socialising with one



another whilst doing so, creating a harmonious working environment. New practical, programming and design skills have been taken aboard and will be fully involved in next year's ROV.

As a bonus to last year's competition the team were invited to take part in the chemistry convention 'Energise your Future', where the original RUFUS worked perfectly and allowed a further showcase of skills.

The project is one to be more than recommended to other schools, as it is an enterprising, fun challenge with a fantastic prize at the end – indeed the worst it is possible to go away with is a bank of new technical knowledge.

References

-www.diy.com.reserve

-www.wikipedia.com

-www.naval-technology.com/projects/lr5/

-www.marinetech.org/rov_competition/2009/regional_contest.php?rov_competition

-'Build your own underwater robot and other wet projects' book, by Harry Bohm and Vickie Jensen

Acknowledgements

As a team, primary thanks goes to Paraic McLoughney, who has helped and advised us through many of the problems we have faced in both this year's and last year's competition, as well as to our mentor, Dougie Simpson, who allowed construction of the ROV in the first place and guided the team through it's various stages, as well as acquiring the necessary equipment. Thanks also goes to Kongsberg for supplying us with the camera they donated last year, as well as any other people and companies who gave information or ideas as how to further our project. Finally, a thank you to MATE Scotland for allowing the competition to run as efficiently and smoothly as it did.