



2018

# MATE ROV COMPETITION MANUAL

## NAVIGATOR

**MATE INTERNATIONAL ROV COMPETITION 2018**

**JET CITY: AIRCRAFT EARTHQUAKES AND ENERGY**

JUNE 21 - 23, 2018  
WEYERHAEUSER KING COUNTY AQUATIC CENTER  
FEDERAL WAY, WASHINGTON, USA

**MTS** marine technology society

**ROV** SOCIETY

**NSI**

**NORA** NATIONAL OCEANOGRAPHIC RESEARCH AND ASSOCIATED INSTITUTIONS

**OCEANEERING**®

**W** UNIVERSITY of WASHINGTON



This work is licensed under a [Creative Commons Attribution-NonCommercial-NoDerivatives 4.0 International License](https://creativecommons.org/licenses/by-nc-nd/4.0/). Under this license you may download and share this presentation. Please give credit to the MATE Center and MATE II. You may not use these materials for commercial purposes without written permission from the MATE Center and MATE II. Please click on the Creative Common link above for license details.

[www.marinetech.org](http://www.marinetech.org)

## 2018 MATE ROV COMPETITION:

### *Jet City: Airplanes, Earthquakes, and Energy*

## NAVIGATOR CLASS COMPETITION MANUAL

For general competition information, including a description of the different competition classes, eligibility, and demonstration requirements, visit [Team Info](#).

## CONTENTS

OVERVIEW .....	2
THINK OF YOURSELVES AS ENTREPRENEURS .....	2
<b>PART 1: PRODUCT DEMONSTRATION.....</b>	<b>3</b>
OVERVIEW .....	3
SCORING OVERVIEW .....	4
TIME.....	4
CONTEXT .....	5
NEED .....	5
REQUEST FOR PROPOSALS (RFP) .....	6
SIZE RESTRICTIONS .....	17
PRODUCT DEMONSTRATION .....	18
TASK 1: AIRCRAFT .....	18
TASK 2: EARTHQUAKES.....	22
TASK 3: ENERGY .....	24
Time bonus: .....	28
PRODUCT DEMONSTRATION RESOURCES .....	28
<b>PART 2: PRODUCT DEMONSTRATION PROP BUILDING INSTRUCTIONS &amp; PHOTOS .....</b>	<b>28</b>
<b>PART 3: VEHICLE DESIGN &amp; BUILDING SPECIFICATIONS .....</b>	<b>29</b>
1.0 GENERAL.....	29

<b>2.0 SAFETY .....</b>	<b>29</b>
2.1 Safety inspection protocol.....	29
2.2 Safety Inspection Completed .....	31
<b>3.0 SPECIFICATIONS .....</b>	<b>31</b>
3.1 Operational.....	31
3.2 Mechanical/Physical .....	32
3.3. Electrical .....	33
3.4 Onboard Electrical Power.....	36
3.5 Power Shutdown .....	36
3.6 Fluid Power .....	36
3.7 Control Systems.....	37
3.8 Cameras and monitors.....	38
3.9. Lasers.....	38
<b>PART 4: COMPETITION RULES.....</b>	<b>38</b>
4.1 GENERAL .....	38
4.2 PROCEDURAL.....	40
4.3 DESIGN & SAFETY CONSIDERATIONS .....	42
<b>PART 5: ENGINEERING &amp; COMMUNICATION.....</b>	<b>44</b>
TIPS FOR EFFECTIVE WRITTEN AND ORAL COMMUNICATION .....	44
5.1 COMPANY SPEC SHEET (ONE PAGE ONLY) .....	45
5.2 TECHNICAL DOCUMENTATION .....	46
5.3 ENGINEERING PRESENTATION .....	47
5.4 MARKETING DISPLAY.....	48
5.5 CORPORATE RESPONSIBILITY (formerly Outreach and Inspiration) .....	49
<b>PART 6: DOCUMENTATION AND KEY DEADLINES .....</b>	<b>50</b>

## OVERVIEW

### THINK OF YOURSELVES AS ENTREPRENEURS

From the exploration of shipwrecks to the remediation of disturbed underwater habitat and installation of instruments on the seafloor, individuals who possess entrepreneurial skills are in high demand and stand out in the crowd of potential job candidates. What are entrepreneurial skills? They include the ability to understand

the breadth of business operations (e.g., finances, research and development, media outreach), work as an integral part of a team, think critically, and apply technical knowledge and skills in new and innovative ways. Individuals who develop a mindset for innovation and collaboration will be well prepared for the global workplace and ready to tackle today – and tomorrow’s – societal challenges.

To help you to better understand and develop these skills, the MATE ROV competition challenges you to think of yourself as an entrepreneur. Your first task is to create a company or organization that specializes in solutions to real-world marine technology problems. Use the following questions as a guide.

- What is your company name?
- Who are its leaders – the CEO (chief executive officer – the leader) and CFO (chief financial officer who oversees the budget and spending)?
- Who manages Government and Regulatory Affairs (i.e. who’s in charge of reviewing the competition rules and making sure that they are understood and followed by everyone)?
- Who is responsible for research and development (R&D)?
- Who is responsible for system(s) engineering? Design integration? Testing? Operations?
- Who is responsible for fund-raising, marketing, and media outreach?
- What other positions might you need? (Depending on your personnel resources, more than one person may fill more than one role.)
- What products and services do you provide?
- Who are your potential clients?

In this case, the MATE Center and the Applied Physics Laboratory at the University of Washington are your “clients” who recently released a request for proposals. A request for proposals (RFP) is a document that an organization posts to solicit bids from potential companies for a product or service. The specifics of your product design and rules of operation as well as the specifics of your product demonstration are included below.

## **PART 1: PRODUCT DEMONSTRATION**

### **OVERVIEW**

**NAVIGATOR** class companies will take part in ONE product demonstration that consists of three distinct tasks:

**TASK #1: AIRCRAFT**

**TASK #2: EARTHQUAKES**

**TASK #3: ENERGY**

**NOTE:** Regional competitions may not include all 3 tasks of the product demonstration; regional competitions may also give companies more than one attempt at the product demonstration. Contact your [regional coordinator](#) or visit your regional contest’s web site to determine what will take place at your regional competition. Regardless, the product demonstration score will be added to your [ENGINEERING &](#)

[COMMUNICATION](#) and [SAFETY](#) scores to determine your total, overall score for the competition.

## SCORING OVERVIEW

The competition consists of product demonstrations, engineering and communication, and safety with the following scoring breakdown:

- **Product demonstrations)**
  - 200 points (max), plus a time bonus
  - Size restrictions
    - 10 points (max)
  - Product demonstration safety and organizational effectiveness
    - 20 points (max)
- **Engineering & Communication**
  - Technical documentation – 50 points (max)
  - Product presentations – 50 points (max)
  - Marketing displays – 50 points (max)
  - Company Spec Sheet – 10 points (max)
  - Corporate Responsibility – 10 points (max)
- **Safety** – 10 points (max)

**TOTAL POINTS = 410**

**NOTE: Regional contests may not require all of the Engineering & Communications components or offer the opportunity to earn points for Corporate Responsibility. Contact your [regional coordinator](#) or visit your regional contest's website for more information.**

## TIME

The time that your company will have to complete the product demonstration will depend on your regional event. Contact your [regional coordinator](#) or visit your regional contest's website to determine how your demonstration will be timed and how long you will have to set up, complete the tasks, demobilize, and exit the station.

At any time during the product demonstration you may pilot your ROV to the surface and remove it from the water for things such as buoyancy adjustments, payload changes, and troubleshooting. However, the product demonstration clock will NOT stop. The only time the clock will stop is if a judge determines that there is an issue that is beyond your control. Otherwise, the clock will only stop after all of the tasks are successfully completed, the ROV has returned to the surface under its own power so that it touches the side of the pool, and a member of your company at the product demonstration station has physically touched the vehicle. Your ROV is not required to return to the surface between tasks.

## **TIME BONUS**

Your company will receive a time bonus if you:

- 1) successfully complete the tasks,
- 2) return your ROV to the surface under its own power so that it touches the side of the pool, and
- 3) physically touch your vehicle before the product demonstration time ends.

How the time bonus is calculated will depend on your regional event. Your regional coordinator will tell you this when he/she explains how your demos will be set up and how much time you'll have to complete them.

## **CONTEXT**

The Pacific Northwest area of Washington State is known for its beautiful and lively geography. It sits between the Olympic and Cascade Mountain ranges, their snowcapped peaks hiding temporarily dormant volcanoes and tectonic plates that are prone to earthquake activity. The combinations of volcanic eruptions and earthquakes have shaped this part of North America, raising the mountains and creating rivers from the snow melt that flow into deepwater lakes. Earthquakes also cause mudslides and landslides that have wiped out large forested areas and resculpted the terrain. A fjord ties the Seattle area to the rest of the world through the Pacific Ocean. Known as Puget Sound, this fjord was formed by these same earth-moving forces. Puget Sound is also vulnerable to another earthquake effect: the tsunami.

Seattle has a history of a wide variety of businesses based on the local geography and natural resources, beginning with logging, farming, and fishing and evolving to high-tech and bio-tech. In addition to this, Seattle is the birthplace of Starbucks, Microsoft, and Boeing, which is why Seattle is known as "Jet City." This only adds to the popularity of the Seattle and Tacoma ports that started booming during the Alaska gold rush. These ports continue to be some of the busiest ports on the west coast today.

The Pacific Northwest has been developed and is constantly changing, but a general respect for the area's rugged beauty has always been there. In light of growing concern for the humankind's impact on our world, people in the Pacific Northwest are leading efforts to research and measure these effects. Brilliant young minds that became leaders in manufacturing and high-tech industries are now coming together to develop renewable energy and reduce the dependence on petroleum. Areas that were impacted by previous industrial activity or environmental disasters are being restored. Invasive species are being removed, while both plant and animal native species are being reintroduced. Organized volunteers educate the public on how to responsibly enjoy all the natural beauty of the Pacific Northwest – and to work to keep it for all to enjoy for generations to come.

## **NEED**

The Applied Physics Laboratory (APL) at the University of Washington (UW) has issued a request for proposals (RFP) for a remotely operated vehicle (ROV) and crew that can operate in salt and fresh water in the Pacific Northwest. The specific tasks for the ROV and operators include:

- 1) Locating the wreckage of a vintage aircraft and returning its engine to the surface.
- 2) Installing or recovering a seismometer.

- 3) Installing a tidal turbine and instrumentation to monitor the environment.

Before launch and operations, the ROV must complete a series of “product demonstrations” staged at a swimming pool at various regional locations. (Depth requirements vary depending on competition class; see **SPECIFICATIONS** below.) The contract will be awarded to companies that successfully complete the product demonstrations and deliver exceptional engineering and communication components (e.g. technical documentation, engineering presentations, and marketing displays).

(Visit [www.youtube.com/watch?v=Tn-jUbpFV4A](http://www.youtube.com/watch?v=Tn-jUbpFV4A) for sound advice from MATE judge Marty Klein. He references 2015, but his words still hold true for this competition season!!

## REQUEST FOR PROPOSALS (RFP)

### 1. General

#### a. Aircraft

From the beginning of human flight to today, the Pacific Northwest has been a part flying history – from dirigibles and fabric biplanes to jumbo jets, from epic pioneering flights to innovative companies making world travel routine. The region’s “history of flight” began in 1910, when American aviator Charles K. Hamilton, known as the “Crazy Man of the Air,” became the first to fly an airplane in Washington State at the Meadows Race Track. The Meadows was the greatest venue in the Northwest for horse racing in the early 20th century; motorcycles and cars also raced there, and airplanes soon followed.

Another event in the region’s history of flight was in 1931 when the first non-stop trans-Pacific flight ended in a cloud of dust near Wenatchee, Washington. More than 41 hours and 8,000 kilometers after departing Misawa, Japan, Clyde Pangborn and Hugh Herndon, Jr. performed a controlled crash landing. They came out of their Bellanca Skyrocket, which they named *Miss Veedoh* for a brand of motor oil, as the first aviators to fly non-stop across the Pacific. It wasn’t until after World War II that another airplane would repeat the non-stop flight. Pangborn had grown up in western Washington, and today, in honor of the journey, the Wenatchee airport is named after him – Pangborn Memorial Airport.



The end of the trans-Pacific journey for the *Miss Veedoh*

<https://www.wired.com/2010/10/1005first-nonstop-transpacific-flight/>

Very few people would argue that the single most important event in the flight history of the Pacific Northwest was the formation of The Boeing Company in Seattle in 1916. William E. Boeing became interested in flight after watching what was happening with the Wright Brothers in Kitty Hawk, North Carolina. What started as a hobby became a business partnership with U.S. Navy Lieutenant and engineer George C. Westervelt. The two teamed up to build the *Bluebell* seaplane, which Boeing took for its first flight in June of 1916. One month later, Boeing created the Pacific Aero Products Company; one year later, he renamed it the Boeing Airplane Company.

From manufacturing a single canvas-and-wood airplane to changing how humans fly over oceans and into the stars, Boeing has become the world's largest aerospace company. The company's impact on Washington State is amazing: according to its 2016 impact report, Boeing is the largest private employer in the state and, in that same year, donated \$1 million in grants to support universities. The report estimated the financial impact of the aerospace industry in Washington at almost \$95 billion, with Boeing being the major contributor. It is because of The Boeing Company's major local influence that Seattle is referred to as "Jet City."

While to most people Boeing is best known for its commercial airplanes (Boeing 737, 777, and 787 are just a few), Boeing is currently the second largest defense contractor in the world and has a history of building airplanes for the military. For example, the Boeing 314 Clipper was a long-range "flying boat" and one of the largest aircraft of the time. It's enormous wing allowed it to achieve the distance necessary for flights across the Atlantic and Pacific Oceans. The Clipper was brought into military service during World War II, where it was used for carrying personnel and equipment to the European and Pacific fronts.



Other Boeing planes also served in World War II. Boeing's B-17 "Flying Fortress" was a four-engine "heavy bomber," which referred to planes that were capable of delivering the largest payload of weapons and flying the farthest distance. The B-17 was mainly used by the United States Army Air Forces in the bombing campaign against German industrial and military targets. Because of the success of this campaign, the Flying Fortress is credited with playing an important role in winning the war.

Boeing's B-29 "Super Fortress," another four-engine, propeller-driven heavy bomber, also played an important role in World War II. The B-29 featured state-of-the-art technology of the time, including a pressurized cabin and an analog computer-controlled system that controlled four remote machine gun turrets and could be operated by a single gunner. The most famous B-29s were the *Enola Gay* and *Bock's Car*, the two planes that delivered the atomic bombs that ended the war in the Pacific.



A Boeing 314 Clipper in flight.

[https://en.wikipedia.org/wiki/Boeing\\_314\\_Clipper](https://en.wikipedia.org/wiki/Boeing_314_Clipper)

In addition to Boeing's planes, a number of other aircraft that took part in World War II and later wars flew in the skies over the Pacific Northwest. The Sand Point Naval Air Station, located at the northwestern end of Lake Washington, saw many of the take-offs and landings; at its high point during World War II, Sand Point was home to more than 5,600 Naval personnel, more than 2,400 civilian workers, and hundreds of aircraft. These included Consolidated Aircraft's PB4Y Privateer patrol bomber and the Chance Vought's Corsair F4U fighter-bomber, among others.

While the majority of take-offs and landings from the air station and nearby Renton Airfield were known about, there appear to be several other operations that were not. Historical records released from Navy show a series of test flights in the early days of the Korean War. According to the de-classified information, not all of these test flights were successful; several airplanes experienced engine trouble, pilot error, or other failures soon after take-off and crash-landed.

There are huge investments of time, money, and technology in the deep and muddy bottom of Lake Washington. These airplanes are especially of interest to vintage aircraft collectors and museums, including the Seattle-based Museum of Flight.

The APL is looking for an ROV to assist with the search and recovery of these aircraft. Specifically, the APL needs contractors for hire who will use flight data available for at least one of these airplanes to determine the area within Lake Washington where it crashed. Once the wreckage is located, the ROV will have to clear debris so that it can recover the airplane, return it to the surface, then use the tail structure and serial number to identify the wreck.

### b. Earthquakes

The Cascadia subduction zone is a convergent tectonic plate boundary that runs from northern Vancouver Island to northern California. This 1,000 km long subduction zone occurs where the Juan de Fuca and North American plates meet. Here, the denser Juan de Fuca oceanic crust plate is moving toward and eventually being thrust under the less dense North American continental plate. While Juan de Fuca plate is being destroyed at this convergent plate boundary, new oceanic crust is being created along the Juan de Fuca mid-ocean ridge, a divergent plate boundary farther offshore. This creation, destruction, and movement of the Earth's crust are all part of the processes known as plate tectonics.

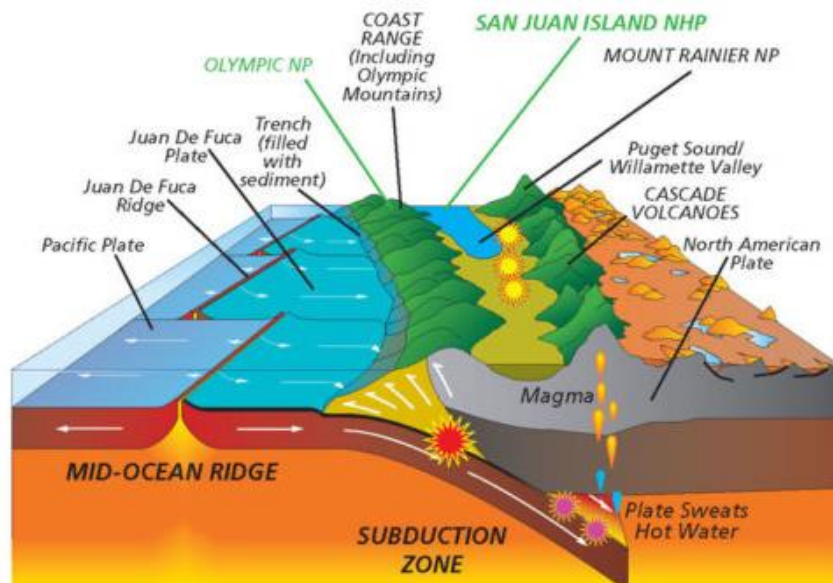

A diagram of the Cascadia subduction zone

<http://www.theeventchronicle.com/news/north-america/june-7-fema-will-hold-drill-prepare-9-0-cascadia-subduction-zone-earthquake-tsunami/>

Along with subduction, the tectonic processes in the Cascadia subduction zone include the accumulation of sediment, deep earthquakes, and the active volcanoes of the Cascade mountain range. Famous eruptions include Mount Mazama (the volcano's collapsed caldera holds Crater

Lake) about 7,500 years ago, Mount Meager about 2,350 years ago, and Mount St. Helens in 1980. The Mount St. Helen's eruption was the deadliest and most financially destructive volcanic event in the history of the United States. Fifty-seven people were killed; 250 homes, 47 bridges, 24 km of railways, and 298 km of highway were destroyed.

Earthquakes along the subduction zone have the potential to cause similar damage. At depths shallower than about 30 km, the zone held by friction while strain from the subduction of the Juan de Fuca plate slowly builds up. When the strain becomes greater than fault's frictional strength, the rocks slip past each other, or "rupture." The result is often a megathrust earthquake with a magnitude that can top 9.0 on the Richter scale. Because of the long length of the fault, the Cascadia subduction zone is capable of producing very large earthquakes.

A megathrust earthquake occurred along the subduction zone in 1700. The earthquake had an estimated magnitude of 8.7–9.2 and took place from mid-Vancouver Island in British Columbia, Canada, south along the Pacific Northwest coast and as far as northern California. The estimated length of the rupture was about 1,000 km with an average slip of 20 m. It caused a tsunami that reached the coast of Japan.

There is geologic evidence that megathrust earthquakes (> magnitude 8.0) have occurred at least seven times in the last 3,500 years along the Cascadia subduction zone, suggesting an average repeat time of about 500 years. Evidence from core samples of the seafloor core shows that there have been 41 subduction zone earthquakes in the subduction zone in the past 10,000 years, suggesting an average earthquake repeat time of only 243 years. Of these 41 earthquakes, 19 have produced a "full margin rupture," where the entire fault opened up. In addition, fossil damage in the Pacific Northwest and historical records from Japan are evidence that these earthquakes often result in tsunamis.

The next rupture of the Cascadia Subduction Zone will likely cause widespread destruction throughout the Pacific Northwest. Scientists estimate that within the next 50 years there is an 84% chance of a magnitude 6.5 or higher earthquake in the Puget Sound region, where both Seattle and Federal Way, the site of the 2018 international competition, are located. The odds are less for Oregon and northern California, but still substantial.

Government agencies, research institutions, and industries all along the Cascadia subduction zone are interested in studying and monitoring earthquake activity. The studies include experiments that use data to model the crust and mantle, as well as the installation of sensors such as ocean bottom seismometers (OBS), hydrophones, and high definition cameras on the seafloor to measure physical, chemical, geological, and biological changes in real time.

For one such project, the APL is currently looking for OBSs that can be installed along the subduction zone and joined to an existing cabled observatory – the Ocean Observatories Initiative Cabled Array (<http://oceanobservatories.org/array/cabled-array/>), which was featured in the [2013](#)

[MATE ROV competition](#). The plan is to connect each OBS to the central power and communications hub so scientists on shore can get the data in real time. The APL is calling for bids on an ROV that install an OBS after releasing it from an “elevator,” which is a platform used to carry equipment, tools, and sensors to the seafloor. Once the OBS is installed, the ROV will need to level it then connect its cable to the power and communications hub.

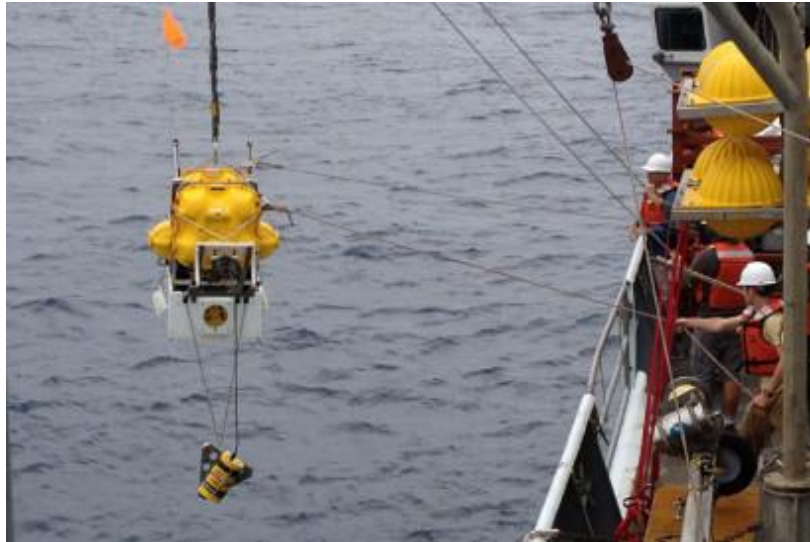

An ocean bottom seismometer being retrieved after spending 10 months on the seafloor.  
<http://news.berkeley.edu/2015/11/02/scientists-map-source-of-northwests-next-big-quake/>

### c. *Energy*

The Pacific Northwest has and continues to invest in researching, developing, and using renewable energy systems. Part of what is motivating this is Initiative 937, which was on the ballot passed by the voters of Washington in November 2006. The law requires that utility companies provide 15% of their power from renewable sources by 2020. The law specifically leaves out hydropower from existing or new dams.

Progress is being made toward this goal. According to a 2013 report by the Renewable Northwest Project, Washington State had invested over \$8.1 billion in new renewables (wind, solar, and bioenergy); the power generation capability of the systems installed was 2,980 megawatts (MW). The estimated number of jobs created from these projects was nearly 4,000. In April 2017, Washington was ranked number two on a list of top ten U.S. states that use the most renewable energy; Oregon was ranked number one.

Recently, a new program for citizens and businesses passed the Washington State Legislature and was signed into law by the Governor. The Senate bill changes tax incentives for renewable energy systems. Projects that are eligible for the program’s incentives include renewable energy systems such as solar photovoltaic energy systems, anaerobic digesters, and wind generators used for producing electricity. The start date for the program was July 2017.

While neither the report nor the bill specifically mentioned tidal energy, Washington State research institutions, government agencies, and industries are looking into the potential of harnessing the energy the results from the moon's, and to some degree the sun's, gravitational pull. There have been and are currently a number of projects that are researching locations for tidal power generators, also known as turbines, in Puget Sound. These studies are looking at tidal current velocity, the bottom topography, and other environmental factors, such as the impact the turbine would have on marine mammals and the benthic community. Given the amount of recreational activity and commercial traffic, including cargo containers bound for the port of Seattle, fishing and aquaculture boats, and the largest fleet of passenger and car ferries in the U.S., shipping lanes and boat traffic must also be taken into consideration.

These projects are also looking into the costs associated with tidal power systems and how practical it is to install and use them. Tidal currents are very predictable, and therefore make it easy to plan for energy production and maintenance. However, how realistic is it to tap into an existing or build a new shore-based power station to receive and use the power? Is the cost of installation and maintenance worth the amount of power that would be generated?

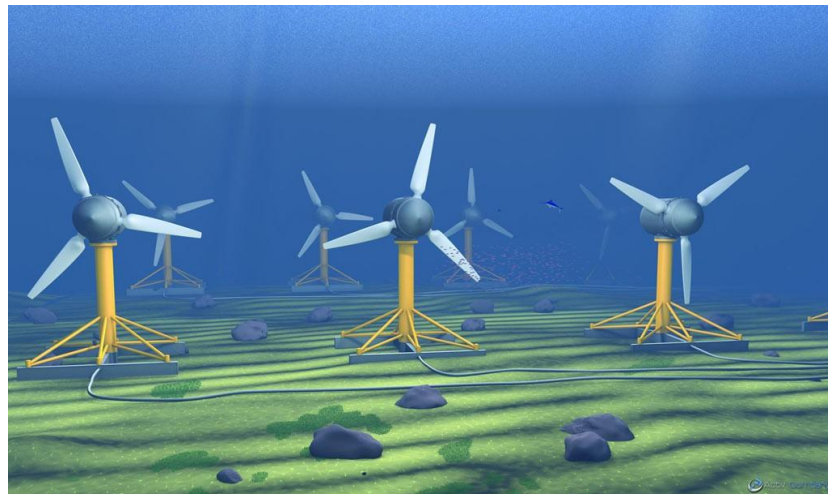

Conceptual drawing of a tidal turbine array

<http://tidalenergytoday.com/2015/05/22/bureau-veritas-issues-updated-guide-on-current-and-tidal-turbines/>



Photo showing the scale and magnitude of the real thing

[http://www.siemens.co.uk/pool/news\\_press/news\\_archive/2012/seagen.jpg](http://www.siemens.co.uk/pool/news_press/news_archive/2012/seagen.jpg)

The best way to capture tidal energy is to place the turbine in a narrow channel between two landmasses. When the tide comes in, the water rises on one side of the channel and pours down the channel to the other side. When the tide goes out, the water on the higher side pours back through the channel where the water level has dropped. The movement of the water turns the rotor, or blade, of the tidal turbine. The turbine is connected to a generator; together these convert the energy of the tidal currents into electricity.

The APL is part of a study lead by the Northwest National Marine Renewable Energy Center (NNMREC) that is looking at the potential of tidal power near Point Wilson, which is located on the mouth of Admiralty Inlet near Port Townsend, Washington. Based on the data collected to date and a sped-up permitting process, the project received the green light to install a single array of tidal turbines on the condition that researchers 1) continues to monitor the area for environmental impact and 2) transplant eelgrass into an nearby area that was previously damaged by dredging. If the installation goes well, the data continues to show little to no negative impact, and an analysis of the cost looks promising, Washington State will put out a contract for bid to install additional tidal arrays.

A team from the APL and the university's Mechanical Engineering Department developed the Intelligent Adaptable Monitoring Package, or I-AMP, to monitor the tidal speed and environmental impacts. The I-AMP is a long fiberglass structure with a number of sensors that include cameras, strobe lights, hydrophones, fish tag receivers, and an acoustic Doppler current profiler (ADCP). The I-AMP is designed to be connected to an ROV that can fly it down and install it on a docking

station on the bottom near a tidal turbine. The docking station includes a data and power cable that runs back to shore, making the data available to researchers in real time.

While the Saab Falcon ROV, affectionately named the Millennium Falcon by APL researchers, was useful for testing the I-AMP in the university's test tank, the APL is now looking for a smaller, light-weight vehicle to install the I-AMP in the study area. In addition, the vehicle will need to place a mooring on the bottom and attach an Acoustic Doppler Velocimeter (ADV), which will measure water velocity and compare to the I-AMP's current measurements, to the mooring. Finally, the ROV will need to both collect samples of eelgrass for analysis in the lab and transplant eelgrass grown in the lab to help restore the damaged area.

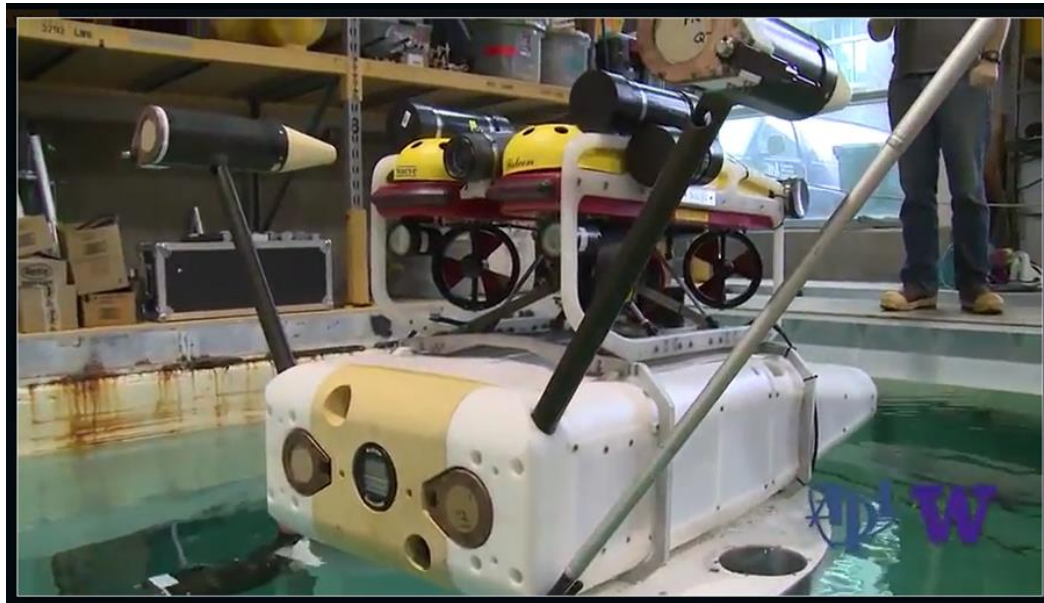

The Saab Falcon ROV deploying the I-AMP in the UW test tank.

<http://www.apl.washington.edu/project/project.php?id=amp>

#### *d. Document Scope and Purpose*

This and the following sections contain the technical specifications and requirements for ROV services needed to support the Applied Physics Laboratory at the University of Washington. In 2018, ROV services include:

##### **1) AIRCRAFT**

- Using flight data to determine the search zone for the wreckage.
- Identifying the aircraft using the tail section.
- Placing a marker buoy at the wreck site.
- Removing debris from the engine using a lift bag.
- Returning the engine to the surface using a lift bag.
- Returning all lift bags to the surface, side of the pool.

## 2) EARTHQUAKES

- Pulling the pin to release the seismometer.
- Removing the seismometer from the elevator.
- Deploying the seismometer.
- Leveling the seismometer.
- Opening the door of the power and communications hub.
- Laying the seismometer cable through a waypoint.
- Inserting the seismometer cable connector into the port on the hub.

## 3) ENERGY

- Using tidal data and nautical charts to determine the optimum region for a tidal turbine.
- Installing a tidal turbine.
- Installing and locking an Intelligent Adaptable Monitoring Package on a stand.
- Placing a mooring a given distance from the base of the tidal turbine.
- Suspending an Acoustic Doppler Velocimeter at a given height on the mooring.
- Eelgrass habitat monitoring and restoration.

## 2. Specifications

See the specific tasks described below as well as the [VEHICLE DESIGN & BUILDING SPECIFICATIONS](#) and [COMPETITION RULES](#) sections.

## 3. Maintenance and Technical Support

The company will guarantee the ROV for the duration of the product demonstrations. Repair or replacement will be at the company's expense. The company will provide at least one day of technical support to deal with any issues.

## 4. Shipping and Storage

Delivery of the ROV will be no later than the date of the nearest regional contest.

## 5. Evaluation Criteria

- a. Technical documentation
- b. Product presentation
- c. Marketing display
- d. Company spec sheet
- e. Product demonstration
- f. Safety

## 6. References

### a. AIRCRAFT

- [http://www.boydski.com/diving/wreck\\_dives.htm](http://www.boydski.com/diving/wreck_dives.htm)
- <http://www.memorieshop.com/Seattle/LakeWashington/>



- <https://vimeo.com/94997616>
- <http://www.cnn.com/2017/08/19/us/uss-indianapolis-wreckage-found/index.html>
- Nelson, Timothy A. *Jet City Rewind*. June 2016. ISBN-13: 978-0764351068
- <http://www.museumofflight.org/Exhibits/first-airplane-flight-washington-state>
- <https://www.wired.com/2010/10/1005first-nonstop-transpacific-flight/>
- <http://www.u-s-history.com/pages/h1832.html>
- [http://www.boeing.com/resources/boeingdotcom/company/about\\_bca/washington/2016-impact-report-01-03-17/impact\\_report\\_010317.pdf](http://www.boeing.com/resources/boeingdotcom/company/about_bca/washington/2016-impact-report-01-03-17/impact_report_010317.pdf)
- <http://www.historylink.org/File/2249>
- [https://en.wikipedia.org/wiki/Boeing\\_B-17\\_Flying\\_Fortress](https://en.wikipedia.org/wiki/Boeing_B-17_Flying_Fortress)
- [https://en.wikipedia.org/wiki/Boeing\\_B-29\\_Superfortress](https://en.wikipedia.org/wiki/Boeing_B-29_Superfortress)

**b. EARTHQUAKES**

- [https://en.wikipedia.org/wiki/Cascadia\\_subduction\\_zone](https://en.wikipedia.org/wiki/Cascadia_subduction_zone)
- <https://www.britannica.com/science/plate-tectonics>
- <http://www.crew.org/earthquake-information/history-of-earthquakes-in-cascadia>
- <https://pnsn.org/outreach/earthquakesources/csz>
- [https://en.wikipedia.org/wiki/Mount\\_St.\\_Helens](https://en.wikipedia.org/wiki/Mount_St._Helens)
- <https://earthquake.usgs.gov/data/crust/cascadia.php>
- [http://www.interactiveoceans.washington.edu/story/Broadband\\_Ocean\\_Bottom\\_Seismometer](http://www.interactiveoceans.washington.edu/story/Broadband_Ocean_Bottom_Seismometer)
- <https://uwerisobservatory.wordpress.com/what/>
- <http://www.apl.uw.edu/project/project.php?id=rsn>

**c. ENERGY**

- <https://climatekids.nasa.gov/tidal-energy/>
- [http://www.energy.wsu.edu/Documents/Renewable%20Energy%20Incentives%20FAQ\\_9-5-17.pdf](http://www.energy.wsu.edu/Documents/Renewable%20Energy%20Incentives%20FAQ_9-5-17.pdf)
- <https://www.usnews.com/news/best-states/slideshows/these-states-use-the-most-renewable-energy>
- <http://en.calameo.com/read/000674314facc79901597>
- <http://www.alternative-energy-tutorials.com/tidal-energy/tidal-energy.html>
- <http://depts.washington.edu/nnmrec/>
- [http://www.apl.washington.edu/project/project.php?id=seafloor\\_tidal\\_power](http://www.apl.washington.edu/project/project.php?id=seafloor_tidal_power)
- <http://www.apl.washington.edu/project/project.php?id=amp>
- <http://blogs.dickinson.edu/ecoreps/2014/04/01/tidal-power-in-puget-sound/>
- <https://energy.gov/eere/articles/calming-waters-impact-turbulence-tidal-energy-systems>
- <http://deepzoom.com/>

**IMPORTANT NOTE: Questions about production demonstrations and design and building specifications must be posted to the competition FAQs board located at [www.marinetech.org/forums/](http://www.marinetech.org/forums/). This allows all companies to see the questions and answers and helps to avoid duplicate questions. That said, please make sure that your question(s) has not already been asked – and answered – before posting. It is up to the**

**companies to read, comprehend, and comply with ALL rulings posted on the FAQ board.**

## SIZE RESTRICTIONS

The Applied Physics Laboratory at the University of Washington has included an ROV size requirement in the request for proposals (RFP). Smaller vehicles will be given special consideration and vehicles above a certain size and weight will not be considered.

All size measurements will include the vehicle, all tools and components, and the tether. The following will NOT be included in the size measurement:

- The topside control system and 1 meter of tether going into the control system

Vehicles will be measured in the on-deck circle 15 to 20 minutes prior to the company's product demonstration runs. Note that the vehicle will be measured before all product demonstration runs. The size bonus, if any, will be added into the product demonstration score.

### 2018 size parameters

Size measurements will be made using the two largest dimensions of the ROV. Two rings with diameters of 48 cm and 60 cm will be located on a table in the on deck circle. Companies will place their vehicles on the measuring table and, when ready, ask a MATE Center judge to make the size measurement. The vehicle measurement must include the vehicle, all manipulators/tools to be used in the product demonstration, and the vehicle's tether. The control system and 1 meter of tether may be outside of the measurement circle. Companies must present their completely assembled ROV for measurement; companies may NOT detach manipulator arms or other equipment for the measurement.

The size rings will be placed over the two largest dimensions of the ROV.

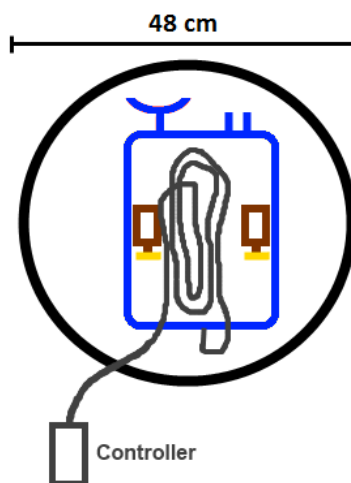

*A NAVIGATOR class vehicle, with tools attached and tether coiled on top, inside the 48 cm diameter ring. This vehicle would earn the company +10 bonus points on the product demonstration score.*

Competition officials will use the following chart to award points:

Size	
< 48 cm diameter	+10 points
48.1 cm to 60 cm	+5 points

Vehicles above 60 cm in diameter will still be allowed to compete, but will receive 0 points for size.

### Size Protocol

Only the four designated product demonstration company members will be allowed into the on-deck circle during and after the size measurement. Once a company's vehicle has been measured, it must remain there until the company moves to its product demonstration station. Companies that detach equipment from the vehicle may not re-install that equipment until the set up period. Companies that detach equipment from the vehicle may not re-install that equipment until the 5-minute set up period. At that time, companies may replace any items that were detached for the measurement, but no new equipment (i.e., equipment that was not included in the size and weight measurements) may be added to the vehicle. If it is discovered that a company added equipment that was not included in the measurements, that company will not be permitted to compete in that product demonstration run.

Videos showing simulated size and weight measurements are posted [here](#).

## PRODUCT DEMONSTRATION

### TASK 1: AIRCRAFT

This task involves the following steps:

- Using flight data to determine the search zone for the wreckage – 10 Points
- Identifying the aircraft using the tail structure – 5 points
- Placing a marker buoy at the wreck site – 5 points
- Removing debris from the engine – up to 10 points
  - Lifting the debris from the engine – 5 points
  - Moving the debris from the wreck area – 5 points
- Return the engine to surface using a lift bag\* – up to 30 points
  - Attaching the lift bag to the engine – 10 points
  - Inflating the lift bag – 10 points
  - Returning the engine and lift bag to surface, side of pool – 10 points

**TOTAL POINTS = 60**

### Product Demonstration Notes:

Companies must complete the steps this task in order. Companies may choose to skip step 1, using the flight data to determine the search zone, but may not go back at a later time to attempt it. Companies are required to remove the debris from the aircraft before inflating the lift bag.

Companies will receive the aircraft's flight data and a map of Lake Washington with four designated search zones at the start of the product demonstration run. The flight data will include:

- location point of take-off
- aircraft heading
- aircraft speed in m/s
- wind direction
- wind speed in m/s
- duration of flight before crashing

Companies will use the flight data to calculate two vectors: flight and wind. Companies will combine these two vectors to determine the search zone for the wreckage. Companies will receive 10 points for successfully identifying the search zone. Companies must show their calculations, or explain to the judges how they determined each of the two vectors. Companies should display both vectors on their map. The result of combining the two vectors will determine the proper search zone for the aircraft. Companies are not allowed to guess the proper search zone. Companies that misidentify the search zone, or choose not to complete this step of the task, can continue with the remaining product demonstration tasks, but will not receive points for using flight data to determine the search zone for the wreckage.

Flight data example:

Aircraft takes off from Naval Air Station Sand Point at a heading of 190°.

Airspeed is 106 m/s.

The aircraft crashed into the lake 70 seconds after take-off.

Wind is blowing from 270°.

Wind speed is 9.4 m/s.

Companies can use this data to determine and plot two vectors on the map and inform the judge what search zone contains the wreckage. Companies must show that station judge the map with the vectors; companies cannot guess.

Companies using the example data would determine the aircraft traveled 7,420 meters (7.42 km) in the direction of 190° and 658 meters (0.66 km) in the direction of 90° before crashing. Using the distance key on the map and the direction provided, companies would determine that the aircraft crashed into Zone 3.

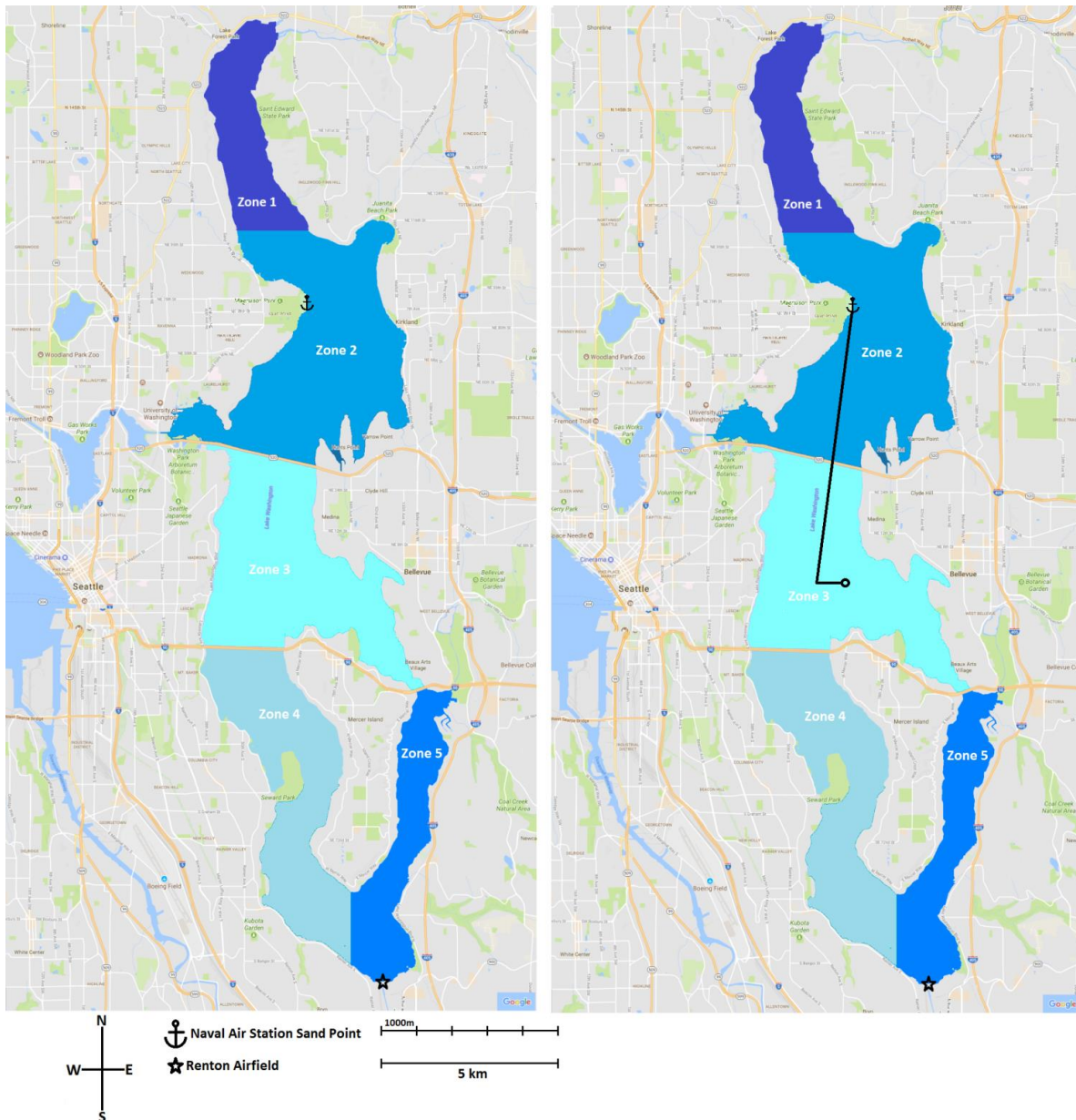

Left: Map of Lake Washington with five search zones defined.

Right: Map of Lake Washington with example flight shown.

[www.google.com/maps](http://www.google.com/maps)

Companies must identify the type of aircraft via a visual inspection of the tail structure. The tail structure will be constructed from ½-inch PVC pipe and corrugated plastic sheeting cut to a particular shape. Different tail shapes will correspond to different airplane types. A serial number will also be printed on one side of the tail. Companies must show the station judge, through their video display, an image of the tail structure and inform the judge of the factors (e.g. tail shape and serial number) used to identify the aircraft. A copy of the [NAVIGATOR Aircraft Identification Handbook](#) will be provided at each product demonstration station. Companies will receive 5 points for successfully identifying the aircraft using the tail structure. Companies that

incorrectly identify the aircraft, or choose not to complete this step of the task, can continue with the remaining product demonstration tasks, but will not receive points for identifying the aircraft using the tail section.

Companies must place a marker buoy at the wreck site. Companies will build their own marker buoy. The marker buoy should consist of a weight that will rest on the bottom, a buoy that will float on the surface, and a rope or line that connects the two. The rope should not be more than 1.3 times the depth of the pool at the wreck site. Companies will receive 5 points when they successfully place their marker buoy at the wreck site. Successfully placing the marker buoy is defined as the weight of the marker buoy adjacent to the wreck site, and the buoy floating on the surface with a line connecting the two.

Companies must remove one piece of debris from the aircraft. The debris will be constructed from ½-inch PVC pipe. A #310 U-bolt will act as a grab point on the debris, but companies may move the debris by any method they wish. Companies will receive 5 points for lifting the debris. Lifting the debris is defined as the debris under control of the ROV and no longer in contact with the pool bottom or any part of the aircraft. Companies will receive 5 points for moving the debris from the wreck area. Moving the debris from the wreck area is defined as the debris laying on the bottom, no longer in contact with any portion of the aircraft or the ROV.

The debris will weigh less than 5 Newtons in water.

After the debris has been moved, companies must attach a lift bag to the aircraft engine. The lift bag will be constructed from 3-inch pipe, will be positively buoyant, and will have a screw hook on the bottom as a way to attach to the engine. The lift bag will be located on the surface, side of the pool and available to companies during the set-up period.

The engine will be constructed from ½-inch PVC pipe and a 2-lb dive weight. A #310 U-bolt will act as an attachment point on the engine. Companies will receive 10 points when they successfully attach the lift bag to the engine. Successfully attaching the lift bag is defined as the screw hook connected to the #310 U-bolt on the engine with the ROV no longer in contact with the lift bag or screw hook.

Companies must then fill the lift bag. Companies must use a MATE provided manual air pump to fill the lift bag with air. The provided air pump will be a bicycle-type manual air pump with airline tubing attached. The far (ROV) end of the airline tubing will have a 7 cm length of ½-inch PVC attached. Companies can attach this PVC to their ROV during the set-up period, so that the ROV is prepared to bring the end of the airline tubing to the lift bag for inflation. Companies will receive 10 points when the aircraft is lifted to the surface. Companies will receive their points when the lift bag breaks the surface of the water.

Once the lift bag and aircraft are on the surface, companies must use their ROV to move the aircraft to the side of the pool. Companies will receive 10 points when the aircraft wreckage is placed on the side of the pool.

## TASK 2: EARTHQUAKES

This task involves the following steps:

- **Deploying the seismometer – up to 30 points**
  - **Pulling the pin to release the ocean bottom seismometer (OBS) from the elevator – 5 points**
  - **Removing the OBS from the elevator – 5 points**
  - **Deploying the OBS into the designated area on the seafloor – 10 points**
  - **Leveling the OBS – 10 points**
- **Connecting the seismometer to the power and communications hub – up to 30 points**
  - **Opening the door of the power and communication hub – 10 points**
  - **Laying the seismometer cable through two waypoints – 5 points each, 10 points total**
  - **Inserting the seismometer cable connector into the port on the hub – 10 points**

**TOTAL POINTS = 60**

### **Product Demonstration Notes:**

For this task, companies may choose to deploy the OBS first or to connect it to the power and communications hub first. The four steps of deploying the OBS must be done in order. Companies may lay the OBS cable through the waypoints before **or** after opening the door of the power and communications hub and inserting the connector.

Companies must pull a pin to release the OBS from the elevator. The pin will be simulated by ½-inch PVC pipe. The pin will be inserted through an opening on both the seismometer and the elevator. Companies will receive 5 points when they successfully remove the pin to release the OBS. Successfully removing the pin is defined as the pin no longer in contact with either the OBS or the elevator. Once removed, the pin may be dropped to the bottom of the pool or returned to the surface.

It will take less than 5 Newtons to pull the pin.

Once released from the elevator, companies must remove the OBS from the elevator. Both the elevator and the OBS will be constructed from ½-inch and 1-inch PVC pipe. A 3 meter length of wire will connect the OBS to the cable connector. A length of 1/8-inch rope will act as a grab point on the seismometer, but companies may remove the seismometer from the elevator by any method they wish. Companies will receive 5 points for successfully removing the OBS from the elevator. Successfully removing the OBS from the elevator is defined as the OBS under control of the ROV and no longer in contact with the pool bottom or the elevator. Note: The cable wire and cable connector attached to the OBS may still be in contact with the elevator.

The seismometer will weigh less than 5 Newtons in water.

After removing the OBS from the elevator, companies must deploy it into a designated zone. The designated zone will be a 40 cm x 40 cm square constructed from ½-inch PVC pipe and painted red. Companies will receive 10 points for successfully deploying the OBS into the designated zone. Successful deployment of the

OBS is defined as the OBS completely within the designated zone, with no part of it touching the PVC of the designated zone, and no longer in contact with the ROV. Note: The seismometer must be right side up to receive points for deployment.

After deploying the OBS, companies must turn a handle to level it. The handle of the OBS will be constructed from ½-inch PVC pipe attached to a ½-inch brass gate valve. Companies must turn the handle of the valve 360° clockwise to level the OBS. Companies will receive 10 points for successfully leveling the OBS. Successfully leveling the OBS is defined as turning the handle 360° clockwise. One segment of the handle will be painted red to help the company determine when it has turned the handle 360°.

The seismometer handle will take less than 5 Newtons to turn.

Companies must also connect the OBS to the power and communications hub.

Companies must open the door of the power and communications hub. The power and communications hub will be constructed from 3-inch pipe and ½-inch PVC pipe. The door, constructed from corrugated plastic, will be mounted over the vertical opening of the port on the hub. The door will be larger than the port and will have a ½-inch PVC handle attached. Companies may use the handle to open the door, or may manipulate the corrugated plastic to open the door. Companies will receive 10 points when they successfully open the door to the port on the power and communications hub. Successfully opening the door is defined as the door moved more than 90° and no longer covering the 3-inch port. If after successfully opening the door the door closes on its own, due to pool currents or ROV activity, companies will not lose points, but may need to re-open the door to insert the OBS cable connector.

Companies must lay the OBS cable through two waypoints. The OBS cable will have a #310 U-bolt on a 1-inch PVC cross as a grab point, but companies may grab the OBS cable by any method they wish. The waypoints will be located partway between the designated zone and the power and communications hub. The waypoints will be constructed of ½-inch PVC pipe in the shape of an X lying flat against pool bottom. The ends of the X will extend 20 cm from the pool bottom. Companies must lay the cable inside two of the vertical extensions. . Companies will receive 10 points for successfully laying the cable through each of the waypoints, 20 points total. Companies may lay the cable through the waypoint before or after inserting the OBS cable connector into the port on the power and communications hub.



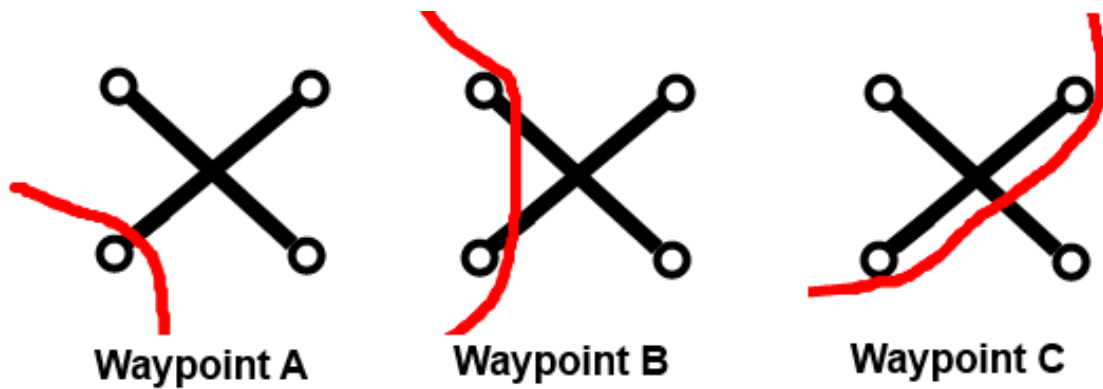

*Depiction of successful and unsuccessful cable lying through waypoints. Waypoint A is an unsuccessful cable lay, as the cable is inside one vertical protrusion only. Waypoint B is a successful cable lay, as the cable is inside two vertical protrusions. Waypoint C is an unsuccessful cable lay, as the cable is only inside one vertical protrusion (the lower right protrusion only).*

Companies must insert the OBS cable connector into the port on the power and communications hub. The door covering the port of the power and communications hub must be open in order to insert the connector. The connector will be constructed from ½-inch PVC pipe. Companies will receive 10 points when the connector is successfully installed in the port on the power and communications hub. Successful installation of the connector is defined as the bottom portion of the connector inside the port, the top of the connector laying on the port, and no part of the connector or cable in contact with the ROV.

### TASK 3: ENERGY

- **Using tidal data and nautical charts to determine the optimum location for a tidal turbine – 5 points**
- **Installing an array of tidal turbines in the optimum location – up to 10 points**
  - **Installing the base on the bottom – 5 points**
  - **Installing the array onto the base – 5 points**
- **Installing an Intelligent Adaptable Monitoring Package (I-AMP) to monitor the area – up to 10 points**
  - **Installing the I-AMP onto its stand – 5 points**
  - **Locking the I-AMP onto the stand – 5 points**
- **Placing a mooring a given distance from the base of the tidal turbine – up to 15 points**
  - **Measuring the given distance from the base – up to 10 points**
    - **Distance is within 10 cm – 10 points**
    - **Distance is not within 10 cm – 0 points**
  - **Placing the mooring on the bottom – 5 points**
- **Attaching an Acoustic Doppler Velocimeter (ADV) onto the mooring – 10 points**
- **Eelgrass habitat monitoring and restoration – up to 20 points**
  - **Collecting two samples of eelgrass for topside analysis – 5 points each, 10 points total**
  - **Transplanting two eelgrass frames to a previously disturbed area – 5 points each, 10 points total**

**Total points = 70**

**Product Demonstration Notes:**

Companies may complete the majority of the steps of this task in any order. However, before installing any equipment, companies must use the tidal data and nautical chart to determine the optimum location. Companies that cannot complete this step may move on to install the equipment, but cannot return to this step at a later time. The equipment, the tidal turbine, I-AMP, and mooring can be installed in any order, although the mooring must be installed before the ADV can be attached to it. The eelgrass habitat monitoring and restoration can be done at any time during the product demonstration.

Companies will use a series of charts from the DeepZoom website ([www.DeepZoom.com](http://www.DeepZoom.com)) to get data on tidal currents in Puget Sound. The charts will match four maximum tidal times over a period of 24 hours. Companies must use the data provided to determine the optimum location for placement of the tidal turbine. The optimum location is defined as the area with the highest combined tidal flow rates during the four time periods. Companies will receive 5 points when they successfully determine the optimum location. If a company fails to identify the optimum location, they will not receive points, but can continue on and but can continue on to other steps of the task.

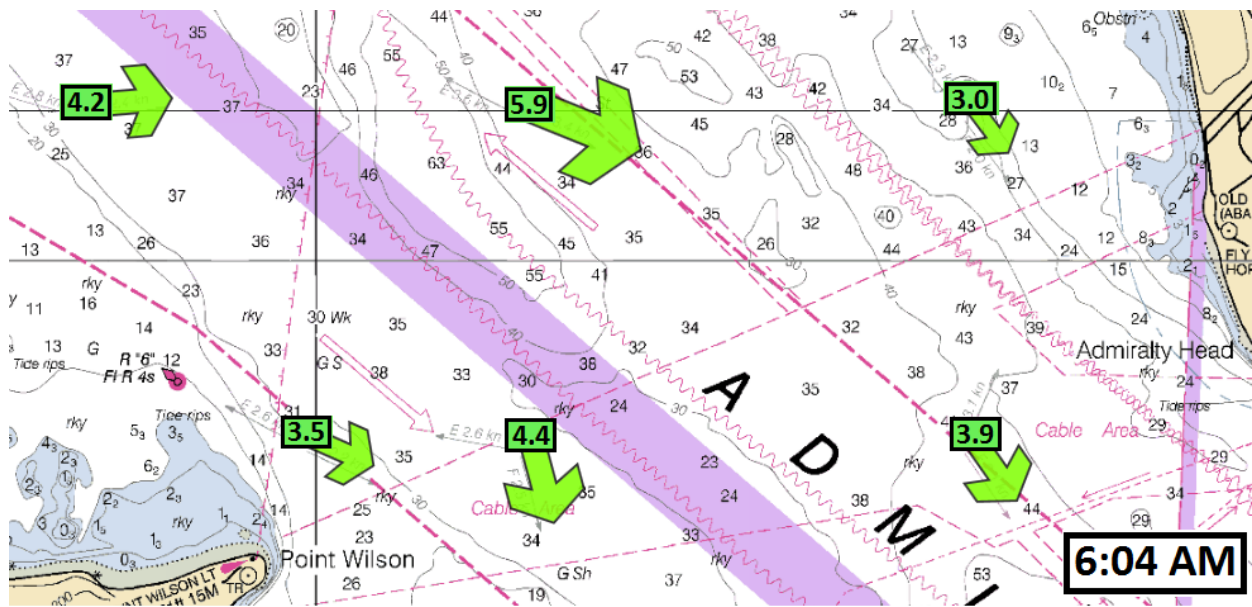

*One chart showing tidal currents in Puget Sound. Companies will receive four of these charts to examine for the highest combined tidal flow rates. In this example, the highest tidal flow rate is 5.9 knots at the top, center.*

Companies must install the base unit for the array of tidal turbine on the pool bottom. The base will be constructed from ½-inch and 2-inch PVC pipe. The 2-inch PVC pipe will be set vertically in the center of the base unit. The array will mount into the 2-inch PVC pipe. Companies must place the base in the designated area, which will simulate the optimum location. The designated area will be a 41 cm square of ½-inch PVC pipe painted red. Companies will receive 5 points when they successfully install the base in the designated area. Successful installation is defined as the legs of the base completely inside the ½-inch pipe of the designated

area, and the 2-inch PVC mounting pipe positioned vertically. No portion of the legs may be on top of the ½-inch PVC pipe of the designated area.

The base will weigh less than 5 Newtons in water.

Once companies have installed the base, the array of tidal turbines must be installed onto the base. The array will be constructed from ½-inch PVC pipe. Plastic airplane propellers, 15 cm long, will simulate the rotors. The array will have four rotors. A #310 U-bolt on top of the tidal turbine can be used as a grab point, but companies may transport the tidal turbine by any method they wish. Companies must install the 1/2-inch pipe at the bottom of the tidal turbine inside the 2-inch PVC pipe rising vertically out of the base. Companies will receive 5 points when the tidal turbine is successfully installed in the 2-inch vertical pipe of the base unit. A section of the 1/2-inch pipe at the bottom of the tidal turbine will be colored red. Successful installation of the tidal turbine is defined as the colored PVC on the bottom of the tidal turbine completely inside the 2-inch pipe of the base.

The tidal turbine array will weigh less than 5 Newtons in water.

Companies must install an intelligent adaptable monitoring package (I-AMP) onto its stand near the tidal turbine array. The I-AMP will be constructed from ½-inch PVC pipe. A length of 1/8-inch polypropylene rope will act as a grab point on the I-AMP, but companies may transport the I-AMP by any method they wish. The stand will be a 40 cm square constructed from ½-inch and ¾-inch PVC pipe that is painted yellow and attached to the base of the tidal turbine array. Companies will receive 5 points when they successfully install the I-AMP on the stand. Successful installation is defined as the I-AMP upright in the stand with both legs of the I-AMP inside the PVC square. No part of the legs of the I-AMP may be resting on or outside of the PVC square.

The I-AMP will weigh less than 5 Newtons in water.

After installing the I-AMP, companies must lock the I-AMP in place. The stand of the I-AMP will have a handle constructed from ½-inch PVC pipe. The handle will be painted yellow. Companies will receive 5 points when they successfully turn the handle, locking the I-AMP in place. Successfully turning the handle and locking the I-AMP in place is defined as the handle rotating 90° and the locking mechanism resting on the pool bottom inside the stand or on the legs of the I-AMP.

The locking mechanism handle will take less than 5 Newtons to turn.

Companies must also place a mooring at a given distance from the base of the tidal turbine. Product demonstration judges will provide companies with the given distance during the 5-minute set up period. A vertical length of PVC pipe near one corner of the tidal turbine's designated area will be the zero mark from which measurements must be taken. A length of ½-inch PVC pipe will extend from corner of the designated area. Colored marks at variable distances along this length of pipe will allow station judges to verify the distance measurement taken by the company. Companies will receive 10 points when they successfully determine the proper distance, within 10 cm, from the zero mark on the designated area. The product

demonstration judge must be able to see or evaluate the measurement taken by the company. No guessing is permitted. Companies that incorrectly measure the distance will be informed by the station judge that their measurement is incorrect. Companies may choose to re-measure the length or continue with the product demonstration. Companies that re-measure the length will receive 5 points if their measurement is correct, within 10 cm. Companies that incorrectly re-measure the length, or choose not to re-measure the length, will receive 0 points. The station judge will then tell the company at what mark to place the mooring.

Companies must then place the base of the mooring on the bottom, at the proper mark determined by their measurement. The base of the mooring will be constructed from ½-inch PVC pipe with weight attached. The mooring line will be constructed from #100 black decorator chain and length of ½-inch PVC pipe with #310 U-bolt attached. A 3-inch ABS pipe with end cap and flotation inside will act as a buoy to hold the mooring up in the water column. A #310 U-bolt attached to the base of the mooring will act as a grab point, but companies may move the mooring by any method they wish. Companies will receive 5 points when they successfully place the mooring on the bottom. Successfully placing the mooring is defined as any part of the PVC base of the mooring adjacent to the measured mark. The chain should extend upwards to the buoy floating on the surface.

Rebar is added inside the base to increase ballast.

The base of the mooring will weigh approximately 3.5 Newtons in water.

The flotation of the mooring will provide approximately 3 Newtons of lift in water.

Once the mooring is in place, companies must attach an Acoustic Doppler Velocimeter (ADV) at a given height. A U-bolt attachment point will be suspended partway up the chain of the mooring. Companies must measure the height above bottom of the attachment point, within 10 cm. The zero mark for the height measurement should be the bottom of the pool directly below the base of the mooring. Companies will receive 10 points when they successfully measure the height of the attachment point, within 10 cm. Companies must show the station judge their distance measurement or inform the station judge how the height measurement was determined. Companies may not guess at the height. Companies that do not successfully measure the height cannot get points for this step, but can continue on and attach their ADV to the mooring.

After the height measurement, companies must attach the ADV to the mooring line. Companies are tasked with building their own simulated (non-working) ADV. The ADV can be constructed out of any material and must:

- Measure at least 20 cm long
- Include a means to connect to the #310 U-bolt on the mooring line
- Not touch the surface or bottom of the pool after attachment to the mooring line

The attachment points will be constructed from a #310 U-bolt set in ½-inch PVC pipe. The ADV must attach to the #310 U-bolt. Companies will receive 10 points for successfully attaching the ADV to the mooring line. Successfully attaching is defined as the ADV remaining attached to the U-bolt for at least 10 seconds after it is released from and no longer in contact with the ROV.

Companies are also required to assist with eelgrass monitoring and restoration. Two samples of eelgrass will be located in the product demonstration area, and two transplant “frames” of eelgrass will be located on the surface, side of the pool. Both the eelgrass samples and the frames will be simulated by green foam sheets attached to ½-inch PVC pipe. Companies must collect the two samples on the pool bottom and return them to the surface. Companies will receive 5 points for each eelgrass sample they return to the surface, 10 points total. Companies must also transplant two frames of eelgrass from the surface to a previously disturbed area. The previously disturbed area will be a 41 cm square of ½-inch PVC pipe painted green. Companies will receive 5 points for each eelgrass frames transplanted into this disturbed area, 10 points total.

Eelgrass samples and frames will each weigh less than 5 Newtons in water.

The turbine base, the turbine, the I-AMP, the mooring, and the two eelgrass frames will be located on the surface, side of the pool at the start of the product demonstration. Companies may lower the turbine stand, the I-AMP, the mooring, and the eelgrass into the water at the side of the pool during the 5 minute set up period, or during the 15 minute product demonstration run. Companies may retrieve these items from the bottom and move them to their designated locations. Companies are not allowed to “toss” or throw these items out into the pool; they must be released at the side of the pool. Companies are required to transport the tidal turbine array from the surface with their ROV; companies may not lower the turbine into the water.

#### **Time bonus:**

If a company has successfully completed all product demonstration tasks and is returning to the surface with the aircraft engine, lift bags, the OBS, and/or eelgrass frames, the product demonstration time will stop when a member of the company touches the vehicle. The engine, lift bags, OBS, and/or eelgrass onboard may be detached and set on the pool deck after the clock has stopped. If any of these items is subsequently dropped from the vehicle and sink to the bottom, the company will not receive points for returning the item to the surface, time will not restart, and the company will not receive a time bonus.

#### **PRODUCT DEMONSTRATION RESOURCES**

The [NAVIGATOR Aircraft Identification Handbook](#) contains identification information on the six types of aircraft believed to be lost in Lake Washington.

## **PART 2: PRODUCT DEMONSTRATION PROP BUILDING INSTRUCTIONS & PHOTOS**

The product demonstration prop building instructions and photos have been made their own, separate document. This document will be released with, but separate from, this competition manual.

## PART 3: VEHICLE DESIGN & BUILDING SPECIFICATIONS

### 1.0 GENERAL

Questions about vehicle design and building specifications, as well as competition rules, should be posted to Competition Help within the MATE Forum Hub ([www.marinetech.org/forums/](http://www.marinetech.org/forums/)). This ensures that all companies can view the questions and answers and helps to avoid duplicate questions. That said, companies should make sure that their questions have not already been asked – and answered – before posting. When posting their question, companies should reference the specific specification (e.g. ELEC-002R).

Conventions: All values contained in this document are threshold values unless specifically stated otherwise. All water depths are given in meters (m). All dimensions and measurements utilize SI units.

Your [regional coordinator](#), or your regional contest's website, will inform you of any specific requirements or changes for your regional.

### 2.0 SAFETY

Safety is the competition's primary concern and guiding principle. Any system that is considered unsafe by competition officials will not be allowed to compete. If a concern is found during the first safety inspection, companies are permitted to attempt to correct it and have their ROV re-inspected. However, the competition schedule will NOT change to allow companies more time. Companies are allowed to have their vehicle re-inspected twice. If a company fails to pass its third and final safety inspection, it is disqualified from the underwater competition portion of the event. There are NO APPEALS once your ROV has been disqualified.

#### Examples of safety violations from previous ROV competitions include:

- The ROV does not use Anderson Powerpole connectors to attach to main power.
- No SID was provided at the safety check.
- The ROV does not have a main fuse.
- The SID did not show a main fuse.
- The ROV used pneumatics, but the technical documentation did not include a pneumatics diagram.
- Sharp items, or potentially sharp items, (fishing hooks, glass bottles) were included on the vehicle.
- The vehicle motors were not waterproofed.
- Propellers were not protected inside the framework or were not shrouded.

#### 2.1 Safety inspection protocol

1. Before entering the water for practice or a product demonstration run, the ROV system must go through a safety inspection. Once a company successfully passes inspection, they will turn in their safety inspection sheet to the safety inspector and receive a Green PASSED Card with their company number on it. Companies must present the Green PASSED Card to the pool practice/product demonstration coordinator before their vehicles are permitted to enter the water.
2. Competition staff will conduct a safety inspection of the vehicle using the safety inspection

3. If the safety inspector(s) identify a safety violation, companies will have the opportunity to address it. The pool practice or product demonstration run schedule will NOT change to allow companies more time.
4. If during the second safety review the
  - a. violation has not been properly addressed or
  - b. another violation is revealed
 companies will have ONE additional opportunity to address the issue.
5. If during the third safety review a violation still exists, companies will not be permitted to participate in the underwater product demonstration component of the competition. However, companies can still participate in the engineering and communication (technical documentation, product presentation, and marketing display) component.
6. Reminder: All companies must present the Green PASSED Card to the pool practice or product demonstration judge before placing their vehicles in the water. In addition, product demonstration station judges and competition officials can pause or stop a product demonstration run at any time if they feel that there is a potential safety concern.

Your regional competition may use a system other than a Green PASSED Card, but all companies must pass a safety inspection before entering the water. Contact your [regional coordinator](#) or visit your regional contest's website to determine if a Green PASSED Card or another system will be used for safety verification.

### 2.1.1 System Interconnection Diagram (SID)

To pass the safety inspection, companies must provide a system interconnection diagram (SID) of their vehicle control system. An SID is an electrical diagram of their wiring, including their control box, motors, and any other electrical systems on their vehicle. The SID should separate and show what systems are on the surface and what systems are on the vehicle. The SID must not exceed one page in length. **The diagram MUST show an ROV system fuse. SIDs that do not show a fuse, utilizing an ANSI, NEMA or IEC symbol, with the size of the fuse marked, will not pass their safety check.**

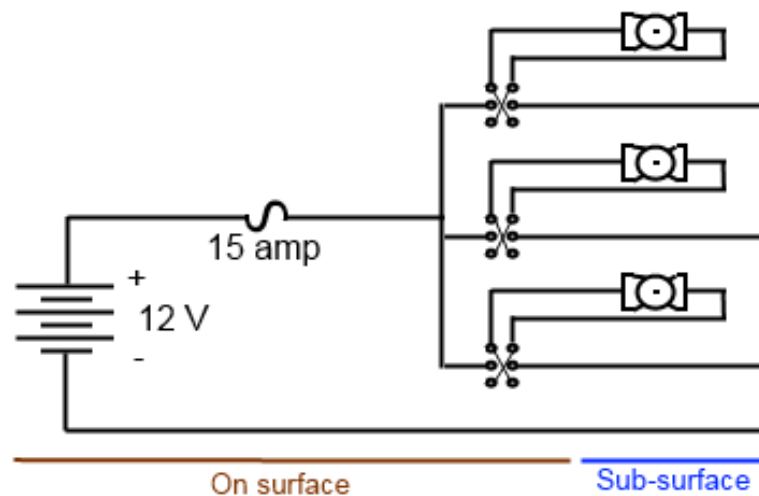



Diagram: An example of an acceptable SID.

Companies should create their own SID. Do not simply copy the above SID, or another SID produced by MATE. SIDs help to understand how electricity flows through your system and will provide a better understanding of ROV operations.

DOC-004: Any electrical diagram should use ANSI, NEMA, or IEC symbols as often as possible; it is required for the fuse. They should be neatly hand drawn or created using a CAD software program.

Item	ANSI	IEC
FUSE		

ANSI: American National Standards Institute

IEC: International Electrotechnical Commission

NEMA: National Electrical Manufacturers Association

Note: Companies that do not hand draw their SID may use free drawing software such as [OpenOffice](#) to create their diagrams.

## 2.2 Safety Inspection Completed

Companies must complete their safety inspection before entering the water for practice or a product demonstration run on the day of the competition.

## 3.0 SPECIFICATIONS

The ROV system (or “system”) must meet the following requirements:

### 3.1 Operational

#### 3.1.1 Multiple Vehicles

OPER-001: MULTIPLE VEHICLES ARE NOT PERMITTED. Companies are required to design and build ONE ROV that can complete the necessary product demonstration tasks. “Floating eyeballs” or other vehicles that are not hard connected to the frame of the main vehicle are NOT permitted. Cameras designed to provide a “birds-eye view” are permitted provided that these cameras are hard connected to the frame of the main vehicle. “Hard connection” does not include the wiring between the camera and the ROV.



### 3.1.2 Environmental

OPER-002: The ROV system must be able to function in fresh, chlorinated water with temperatures between 15°C and 30°C. The water should be considered conductive of electrical currents.

OPER-003: The pool will not be covered or purposefully darkened in any way, although the specific product demonstration tasks may require that your ROV operates in low-light.

OPER-004: No water currents will be intentionally created. However, depending on the venue, pressurized pool filtration system outlets may cause unexpected currents.

**Note:** Contact your [regional coordinator](#) or visit your regional contest's website to learn more about the environmental operating conditions of the competition pool. Some pools may have sloping bottoms or other features that could affect your ROV's performance.

### 3.1.3 Service Requirement

OPER-005: Companies shall provide a product demonstration team of at least 3 but no more than 4 people to operate the ROV on the pool deck. Companies may have more than 4 people, but only 4 company members are allowed on the pool deck to operate the vehicle.

### 3.1.4 Maintenance and Calibration Requirement

OPER-006: System maintenance during field operations shall be conducted by ROV personnel at their workstations. Work of any kind must not be done by company mentors or advisors. All maintenance parts and equipment necessary to meet the operation requirements shall be provided by the company. More information about these regulations is provided in the [COMPETITION RULES](#).

OPER-007: All measurement devices shall be calibrated according to manufacturer recommended calibration procedures and performed by company members only. Company mentors or advisors are not permitted to perform calibration procedures. More information about mentor restrictions is provided in the [COMPETITION RULES](#).

## 3.2 Mechanical/Physical

This section of the document provides specifications for the mechanical properties of the ROV system.

### 3.2.1 Materials

MECH-001: Any electronics housings on the ROV shall be capable of operating to depths of 4 meters.

### 3.2.2 Size

MECH-002: ROVs are not limited to a maximum size, but companies must be able to personally transport the vehicle and associated equipment to the product demonstration station and to the product presentation room. ROV systems must be capable of being safely hand launched. Additional points will be given to smaller, lighter vehicles (see [size restrictions](#)).

### 3.2.3 Tether Length

MECH-003N: ROVs must be capable of operating in a maximum pool depth of 4 meters (13 feet). All underwater product demonstration will take place within 8 meters from the side of the pool. The product demonstration station will be no more than 3 meters from the side of the pool. Tether length should be calculated accordingly.

**Note:** Many NAVIGATOR class competitions are held in water less than 4 meters deep. Contact your [regional coordinator](#) or visit your regional contest's website to determine the maximum depth of the NAVIGATOR competition.

### 3.2.4 Vehicle Deployment and Recovery

MECH-004N: The product demonstration team (up to 4 people) must be able to carry the entire vehicle by hand. The crew must be able to hand launch and recover the ROV. No lifts or levers may be used to launch the ROV.

### 3.2.5 Propellers

MECH-005N: Propellers must be enclosed inside the frame of the ROV or shrouded. Companies that have propellers protruding outside of their frame will not pass the safety inspection and will not be allowed to compete.

## 3.3. Electrical

ELEC-001N: All power provided to your ROV system must be obtained from the MATE competition power supply. This is a singular point of connection; all power to your ROV must pass through the MATE-provided fuse on the supply AND the single fuse in your wiring.

ELEC-002N: MATE will provide a nominal 12 volt power source at the product demonstration station. This power source may be a battery or a power supply. Nominal voltage may be as high as 14.8 volts.

ELEC-003N: Voltage may never be increased above the nominal 12 volts anywhere in the ROV system.

### 3.3.1 Current

ELEC-004N: The ROV **MUST** have a 15A maximum fuse in the positive power supply line within 30 cm of the positive Anderson powerpole connector. The SID must show this fuse, using a proper fuse symbol, and include the amperage rating of the fuse.

### **New in 2018!!!**

ELEC-005N: ROV systems are allowed only one replacement fuse during the product demonstration run. In the event that the ROV system blows the second fuse during the product demonstration, time will stop, the product demonstration run will be over, and no additional points will be earned. Note: Companies must provide their own replacement fuses. MATE will not provide replacement fuses.

### 3.3.2 Power Connections

ELEC-006N: The MATE Center requires that all ROVs use Anderson power pole connections (<https://seamate.org/collections/power-related-products/products/seamate-angelfish-pufferfish-power-kit-with-powerpole-connectors>, <https://powerwerx.com/anderson-powerpole-connectors-30amp-bonded>).

Power supply connections at all regional competitions will be Red/Black Anderson Powerpole Connectors.

Anderson power pole connections are two-piece connectors as shown in the picture below.



### Part specification and part numbers

Anderson Power Pole – Red and Black connector with 30 amp contacts

Red is connected to power supply positive.

Black is connected to power supply negative.

Since Anderson sells the connectors in 2500 and 200 piece quantities, these connectors are available from distributors.

For those who want more information on Anderson power pole connectors:

Distributor Part Number:

Connector & Pins: Powerwerx WP30-10 (This is a kit with 10 connector sets and 30 amp pins for approx \$12 USD)

Recommended Crimper: TRICrimp

<http://www.powerwerx.com/crimping-tools/tricrimp-crimping-powerpole-contacts.html>

Connector Sources:

<http://www.powerwerx.com/anderson-powerpoles/powerpole-sets/30-amp-permanently-bonded-red-black-anderson-powerpole-sets.html>

<http://www.aesham.com/power-distribution/powerpoles/powerwerx-wp30-10/>

[http://www.gigaparts.com/Product-Lines/Power\\_2/Powerwerx-WP30-10.html](http://www.gigaparts.com/Product-Lines/Power_2/Powerwerx-WP30-10.html)

<http://www.hamradio.com/detail.cfm?pid=71-001833>

### Powerpole related links

Powerpole Data Sheet

[http://www.andersonpower.com/\\_global-assets/downloads/pdf/ds-pp1545.pdf](http://www.andersonpower.com/_global-assets/downloads/pdf/ds-pp1545.pdf)

Powerpole Description

[https://en.wikipedia.org/wiki/Anderson\\_Powerpole](https://en.wikipedia.org/wiki/Anderson_Powerpole)

Powerpole Assembly Instructions

<http://www.powerwerx.com/assembly.asp>

<http://www.wb3w.net/powerpoleinst.htm> (see the section on using the TriCrimp tool)

YouTube Video for Assembly

Part 1: [https://www.youtube.com/watch?v=8\\_DPPuQN8R4](https://www.youtube.com/watch?v=8_DPPuQN8R4)

Part 2: <https://www.youtube.com/watch?v=EsSsr2zGFqI>

ELEC-007N: The power supply may be located up to 1 meter from the station table and may be located on either side of the table. MATE recommends a power cable long enough to reach the power supply up to 3 meters from your control system.

### 3.3.3 Tether Voltages

The signals in the tether must meet the following specifications:

ELEC-008N: Low voltage, low current AC or DC control or sensor signals. Low voltage is defined as a voltage equal to or less than the maximum supply voltage per class specification. Low current is defined as being less than 500 mA.

**Note:** Companies concerned about how voltage loss will affect their camera(s) should consider adding a separate line in the tether to supply the camera from the main power source. This dedicated line for cameras is permitted, provided it runs through the single fuse or circuit breaker.

ELEC-009N: DC main-supply at a nominal voltage of 12VDC as provided by the MATE power supply.

ELEC-010N: Ethernet, USB, or other ANSI or IEC accepted serial protocol signals.

All cameras, including USB cameras, must be powered by the MATE supply. Power a USB camera from the MATE supply can be accomplished by using a USB repeater / extender that has a separate power input at the far (ROV) end. The ROV would then provide the power to the device from the MATE supply. USB cameras directly plugged into laptops or surface computers are not allowed.

ELEC-011N: NTSC or PAL Video signals

ELEC-012N: Fiber optic cabling of any type may be used.

### 3.3.4 Exposed connections and disposable motors

ELEC-013N: All electrical components going into the water must be waterproofed. ROVs with electrical connections that are exposed to the water and not sealed will not be permitted to enter the pool. Disposable motors (motors with no waterproofing) are not permitted. Taping a connection with only electrical tape does not constitute a sealed connection. The process of sealing electrical connections must include methodologies such as, but not limited to, silicone RTV, hot melt glue, epoxy, self-vulcanizing tape, and enclosing the connection inside a housing.

### 3.4 Onboard Electrical Power

ELEC-015N: Onboard electrical power (i.e., power not provided by the tether): Onboard battery powered devices are NOT allowed under any circumstance.

**NOTE:** *Water leaking into a closed battery container can result in the generation of hydrogen gas. This gas can build up inside a pressure housing and create an unsafe situation. For this reason, onboard batteries are NOT allowed under any circumstance. Any device that needs power must obtain that power directly from the ROV tether. For devices that operate at a voltage other than the tether voltage, an onboard ROV converter may be included. The converter must be sealed and not exposed to water. This rule includes commercial “watertight” battery containers; no battery of any type is permitted on any competition vehicle.*

### 3.5 Power Shutdown

ELEC-016N: Power shutdown: For safety purposes, any ROV that is disconnected from the surface power supply must stop functioning in less than 5 seconds.

### 3.6 Fluid Power

Any vehicle using fluid power must provide a fluid power diagram. Fluid power is defined as hydraulic pumps (water) or pneumatic pumps (air) on the vehicle or on the surface. NOTE: Companies are not required to submit a fluid power diagram if they are only using the MATE-supplied manual pump and airline tubing for Task 1: Aircraft.

FLUID-001N: Electrical pumps of any sort are NOT allowed. Companies may only use manual pumps (hand or foot pumps) to push fluids down the tether and to their vehicle. Companies may only use the MATE-supplied manual pump to fill the lift bag for Task 1: Aircraft. If companies wish to use a pump for other purposes, they must supply their own pump; the pump provided by MATE can only be used to fill the lift bag.

FLUID-002N: Companies may only use WATER as their hydraulic fluid. Companies may only use AIR as their pneumatic fluid.

FLUID-003N: Companies may not use pressure accumulators. Pressure inside any container must never exceed the ambient pool pressure. If air is pumped into a container on the vehicle, that container must be open to the water. Vent holes on the container must be at least ¼-inch (6.35 mm) in diameter.

For example: A company wants to fill a PVC pipe container on the vehicle with air. Companies may only use a manual pump (hand/foot powered bicycle pump) to push air down to the vehicle. The company drills four ¼-inch holes in the bottom of the pipe. As they pump air into the container, it will displace the water out of the holes in the bottom of the pipe. However, the pressure inside the container can never get above the ambient pool pressure; excess air will come out the holes on the bottom of the pipe once all the water has been displaced.

### 3.7 Control Systems

ELEC-017N: NAVIGATOR companies are not limited to the type of control system they may use provided it complies with the other MATE design and safety specifications.

ELEC-018N: Surface control stations must be built in a neat and workmanship like manner. Loose components and unsecured wires will not pass safety inspection.

ELEC-019N: Surface control stations by nature may combine 120 VAC and 12 VDC wiring. The surface control stations must be wired in a manner such that the 120 VAC wiring is physically separated from the DC wiring, the 120 VAC wiring is clearly identified from the DC and control voltages, and every conductor is insulated in a manner that no conductor is exposed. Identification can be through signage and/or wire color schemes. All 120 VAC wiring colors must use ANSI, NEMA or IEC standard wiring colors appropriate to each voltage. There must be a sign inside the surface control station indicating which wiring standard is being utilized. Companies that do not have adequate separation of AC wires and components and DC wires and components will NOT pass the safety inspection. It is recommended that separation be designed into the control system to keep power systems separate. Wiring should be clear, neat, and easy to follow by inspectors. Wiring “rat’s nests” or “spaghetti wiring” will not pass safety inspection.

ELEC-020N: Companies must use proper strain relief and abrasion protection where wires and the tether enter the vehicle and enter the control box. The ROV should be capable of being lifted by the tether without damaging the tether connection to the ROV.

### 3.8 Cameras and monitors

CAM-001N: Companies are limited to ONE video display screen. This display screen may be powered by the MATE provided GFI-protected 115-Volt AC (60-cycle) and 15-amp AC power source described in CAM-002, Surface power.

CAM-002: Surface power: MATE will provide one GFI-protected outlet with a nominal 115 Volts AC (60 Hertz) and 15 amps maximum. This outlet is intended to provide power for the video monitor. This AC power source CANNOT be used to directly or indirectly power the vehicle.

#### 3.8.1 MATE Provided Equipment

MATE will not provide monitors at NAVIGATOR product demonstration stations this year. Companies are responsible for providing their own video monitor.

### 3.9. Lasers

NAVIGATOR class companies may NOT use lasers on their vehicle.

## PART 4: COMPETITION RULES

### 4.1 GENERAL

- All members of the company and their supporters must follow the safety regulations of the ROV competition, pool facility, and event venue.
- All company members and their supporters are expected to conduct themselves in a professional and responsible manner during the competition. Disrespectful behavior towards the judges, officials, pool staff, audience, or other companies will lead to penalty points or disqualification.
- Sabotaging, stealing, or pilfering equipment of other companies will lead to disqualification. Companies found cheating will also be disqualified.
- The MATE ROV competition is, at its core, designed to be an educational and inspirational event for **STUDENTS**. It is designed to challenge them to apply the physics, math, electronics, and engineering skills they are learning in the classroom to solving practical problems from the marine workplace. (See the [MATE Competition Philosophy](#).)

It is expected that all “adults” (non-students; e.g. teachers, mentors, parents) involved in the competition limit their input to educational and inspirational roles. Actual construction of the ROV

(particularly in the complex electrical and software areas) must be completed by the students. Adults should teach and advise students about design, electronics, software, and construction, but not complete the work for the students. Throughout the process adults are encouraged to focus on benefits to the students from the process and not simply winning. If it becomes apparent that adults exercised more than an advisory role, judges reserve the right to deduct points or, in extreme cases, disqualify companies from the competition.

ALL work done on the vehicle must be conducted by company members. This includes any work done at home, at school, or during the MATE ROV competition (international and regional). Teachers, mentors, parents, and non-competing students are not permitted to work on the ROVs. They may provide advisory input, but they may not work on the ROV directly. This includes writing or editing software code. All mechanical, electrical, and software modifications and/or repairs to the ROV must be completed by students.

With learning at its core, the MATE competition encourages students to utilize and build upon their skill sets to find creative solutions to designing and building their ROV. Students gain valuable skills and knowledge when creating a component from “scratch,” which is apparent to judges as they review the technical documentation and engineering presentation. However, as they move through the process of analyzing their designs and identifying building materials, students may decide to either build a component from “scratch” or purchase it from a commercial vendor.\*\*\* So, while original solutions are encouraged, the use of commercial components is acceptable, provided 1) that the components adhere to the design and building as well as safety specifications for the particular competition class and 2) more importantly, that the students can provide a reasonable, logical explanation for buying versus building.

The competition scoring rubrics are designed to reflect this; points are awarded based on students’ abilities to explain and justify how all of the components and systems work together as an integrated ROV, regardless if they purchased them, pulled them from public libraries, or made them themselves.

\*\*\*Note “commercial vendor” includes the SeaMATE store and other competition programs that sell educational robotics kits. SeaMATE kits were created to remove barriers to participation for teachers and schools unable to easily 1) find parts and materials and 2) set up accounts with multiple vendors. The kits are part of a larger educational package offered by the MATE Center that includes curriculum materials, videos, and other resources to support and enhance learning. And learning is what students who use SeaMATE (or other) kits will be expected to demonstrate during and through the [ENGINEERING & COMMUNICATION](#) components.

It should be noted that purchasing and competing with complete, assembled, commercial ROVs is not permitted.



## 4.2 PROCEDURAL

- Companies must compete during their assigned time slots. Your company is **NOT** permitted to switch time slots with another company. Failure to show for your scheduled product demonstration or for your company’s product presentation will result in “no score” for that particular competition category. **No exceptions.** Assigned time slots will be sent out in advance so that any scheduling concerns can be addressed prior to the event. Contact your [regional coordinator](#) at least four weeks before the competition if you know you have a scheduling concern.
- Companies must complete their size measurements before each product demonstration run. The size measurements are included as part of the product demonstration score. Companies should be at the size in area at least 15 to 20 minutes before their scheduled product demonstration run.
- While there is no limit to the number of students who can compete as part of a company, **the product demonstration team (aka demo team) is limited to four students.** The demo team is defined as the team of students who operate the vehicle and its associated equipment during the product demonstration. The product demonstration is held at a “product demonstration station.” Only four students will be allowed to enter the product demonstration station, launch, pilot, and perform the tasks. Instructors, mentors, and/or non-student members cannot participate as part of the demo team. If a regional offers two product demonstration attempts, **companies may alternate students on the demo team for the two product demonstrations. See below for additional information about the number of attempts.** (All members of the company should participate in the engineering and communication components; see [ENGINEERING & COMMUNICATION](#) for more information.)
- Only the demo team members and judges are allowed at the product demonstration station during the product demonstration, which includes the set-up and demobilization periods. Other members of the company, instructors, mentors, audience members, and observers (press or special invited guests) must remain outside the product demonstration station or in designated viewing areas.
- Instructors, mentors, parents, and “fans” are **NOT** permitted at the safety inspection stations or repair tables. Two warnings will be issued before individuals not following this rule will be asked to leave the venue.
- In addition, instructors, mentors, parents, and fans are **NOT** permitted to work on the ROV. Individuals who are seen working on the ROV who are not student company members will be issued a warning. Two warnings will be issued before individuals not following this rule will be asked to leave the venue. If companies choose to take their ROVs off the competition grounds for maintenance and repair, they are expected to observe this rule in the interests of the spirit of the competition.

- Video devices may be used to record the underwater activities for entertainment and learning purposes **only**. Video will not be used as an instant replay to review judges' decisions or to challenge product demonstration timing.
- Companies will compete in ONE product demonstration that consists of three distinct tasks. Companies may get up to **TWO** attempts to complete each product demonstrations. If that is the case, the **higher** of the two scores will be added to the engineering and communication score to determine the total, overall score for the competition.
- The product demonstration time consists of a 5-minute set-up period, a 15-minute performance period, and a 5-minute demobilization period. If the demo team and all of their equipment are not out of the product demonstration station at the end of the 5-minute demobilization period, the company will be **penalized 1 point for each additional minute**.

**Note:** Regional contests may or may NOT offer companies two attempts at the product demonstration tasks. In addition, the product demonstration time frames for set-up, performance period, and demobilization may be different at your regional contest. Contact the [regional coordinator](#) in your area or visit your regional contest's website for more information.

- Manipulating the tether to free it from underwater obstacles is permitted. Pulling on the tether to speed up the recovery of items or to return your vehicle more quickly to the surface is not permitted and will result in penalty points. Judges will issue one warning if tether pulling occurs. Each future infraction will result in **5** points deducted from the final product demonstration score.
- If your vehicle is completely disabled and/or its tether tangled and unable to free itself from the underwater environment, SCUBA divers can be called in to assist. However, the product demonstration time will NOT stop and **5** points will be deducted from the final product demonstration score.

Diver assistance may not be available at your regional competition. Contact your [regional coordinator](#) or your regional contest's web site to determine if diver assistance will be available at your regional competition.

- Pilots can only leave the product demonstration station and move poolside to repair, adjust, or alter a vehicle if the ROV is surfaced and at the side of the pool.
- Companies are not permitted to leave debris in the pool. Any debris must be recovered by the ROV before time has expired or the company will be penalized. Debris is defined as pieces of the ROVs, weights, floats, or other items created by the company. Task props are not considered debris. The product demonstration notes section may cover special items that can be left in the pool after time has expired.

- No demo team member shall enter the water to complete an object recovery. Only arms and hands are allowed into the pool to retrieve an object or to retrieve the vehicle. Companies will be disqualified or penalized depending on the severity of the infraction.
- Communication between demo team members at the pool edge and demo team members piloting the vehicle will be limited. Only tether management issues (e.g. how much tether is out, how much is remaining on the pool deck) can be discussed. Those team members at the pool edge cannot give any directional or product demonstration task information to the pilot. Judges will issue one warning regarding illegal communication. Each future infraction will result in **5** points deducted from the final product demonstration score.
- Communication using cell phones, text messaging, and online social media tools such as Skype, Facebook, Twitter, instant messaging, etc. is **NOT** permitted during the product demonstration, either between the demo team members at poolside or between any demo team member and anyone outside of the product demonstration station. The ROV and/or the ROV control system is not allowed to broadcast video or other information to anyone outside of the product demonstration area. No exceptions. Companies found broadcasting any data to those outside of the product demonstration area will be disqualified.
- **Product demonstration judges and other competition officials will only communicate with students.** Judges and officials will **NOT** communicate with mentors, parents, or other non-student members regarding product demonstration information, challenges, or other issues except during pre- and post-competition briefing sessions.

Companies that wish to issue a challenge during the product demonstration run should immediately communicate this challenge to the product demonstration judges. The judges will discuss and attempt to resolve the issue. If a decision cannot be made, the product demonstration judges will consult with the head judges and competition technical manager to resolve the issue.

### 4.3 DESIGN & SAFETY CONSIDERATIONS

- The competition coordinators and host venues stress the importance of safety practices and procedures to all companies. The score sheets and rubrics will reflect the MATE Center's efforts to encourage and reward companies that demonstrate exceptional safety practices and procedures.
- **ALL ROVS MUST PASS A SAFETY INSPECTION CONDUCTED BY COMPETITION OFFICIALS PRIOR TO ENTERING THE POOL.** These inspections will be conducted topside to ensure that ROV systems meet the design and building specifications and do not pose a risk to the integrity of the event venue. See [VEHICLE DESIGN & BUILDING SPECIFICATIONS](#) for additional information.

- **ROV MOTORS MUST BE WATERPROOFED!** No exceptions. You may use already waterproofed motors (bilge pump motors, etc.) or you may choose to waterproof small electrical motors. Methods for waterproofing electric motors can be found on the competition web site [www.marinetech.org](http://www.marinetech.org) as well as in the little yellow book “Build Your Own Underwater Robot and Other Wet Projects.”
- Propellers must be enclosed inside the frame of the ROV or shrouded. **Companies that have propellers protruding outside of their frame will not pass the safety inspection and will not be allowed to compete.**
- Radio transmitters that operate on a separate battery are permitted. No batteries are permitted to be in or on the water. No exceptions.

Companies should be aware of all the implications of these wireless devices. There is no assurance that an adjacent company’s wireless controller will not interfere with your control systems. Adjacent wireless controllers with a battery that has a higher charge than the nearby controller have demonstrated the ability to “hijack” the nearby control signals. In addition, all wireless controllers are susceptible to external sources of electronic interference. Your system may work fine in your home environment, but not in the industrial environment of the competition. MATE will not stop the clock to resolve wireless control issues. Companies deciding to utilize wireless controllers do so at their own risk.

- Safety must also be a priority when operating your ROV poolside. Keep an eye out for tripping hazards. Make sure that your connections to the battery or power supply are not lying in pools of water on the deck. During your product demonstration, be sure to secure any equipment so that it does not fall, damage the deck, or cause injury.
- Loose fitting clothing, jewelry, and long hair could all become safety issues. Consider securing long shirts or baggy pants, removing jewelry, and tying back long hair when working on or operating your ROV.
- ROVs may be constructed out of materials of your company’s choice, provided they meet the design and building specifications and safety regulations. Warning labels should be posted on potentially hazardous components of your ROV system.
- **Closed-toed shoes are required on the pool deck and anytime you are working on your ROV.** Safety glasses or goggles should be worn when working on your ROV.
- Personal flotation devices (PFDs) may be required when launching and recovering your vehicles. Contact your [regional coordinator](#) or visit your regional contest’s website to determine whether this

is a requirement at your regional event. If PFDs are required, they will be provided by the regional coordinator.

## PART 5: ENGINEERING & COMMUNICATION

The ability to effectively communicate information about your vehicle and the design and building process is equally as important as how well your vehicle performs. Strong communication skills are an essential part of good business practices. To emphasize this point, the competition requires the following four engineering and communication components:

- Company spec sheet
- Technical documentation (formerly known as the technical report)
- Engineering presentation (formerly known as the product presentation)
- Marketing display (formerly known as the poster display)

**IMPORTANT NOTE:** Regional contests may not require all of the Engineering & Communication components. Contact your [regional coordinator](#) or your regional contest's web site for more information.

The company spec Sheet, technical documentation, and engineering presentation are components where you are communicating with technical audiences, such as potential future clients. (Examples of spec sheets and technical documentation from previous competitions can be found [www.marinetech.org/tech-reports](http://www.marinetech.org/tech-reports). Examples of engineering presentations can be found on [MATE's Vimeo channel](#).) The marketing display should be thought of as part of your marketing (or sales) strategy and aimed at general (including non-technical) audiences.

### TIPS FOR EFFECTIVE WRITTEN AND ORAL COMMUNICATION

Communicating ideas about how to solve a problem and evaluating those ideas is a critical skill for anyone thinking about a career in marine technology. It is a skill that is directly linked to decision making about whether or not to hire (or fund) us and our ability to affect the work that we do.

The key to a successful technical documentation and product presentation is the way that critical thinking and engineering reasoning are communicated. You can think of the process as technical “storytelling.”

Technical storytelling includes the use of text, images, diagrams, and data to communicate the “story” of how your company brainstormed and evaluated ideas to come up with your solution (e.g. ROV, payload tools) to the problem at hand (tasks). It also involves organizing the information to efficiently present your work and justify why you did what you did.

However, choose details with care. Each detail should help to answer the question "why is what you did the best solution for your company and for this competition?" Describe why a component in the system is critical and how you chose it. Include specifications or dimensions only if they help to explain the "why" and "how" you made choices. Keep in mind that a mechanical drawing with dimensions can replace a lot of text and in many cases do a better job telling details of the story than text.

That said, if something is hard to describe clearly and completely with two to three sentences, consider whether using an image may help. A good technical document balances text and images to provide lots of information concisely, giving a detailed understanding while being quick and easy to read. Remember that your reader is new to your design and needs to understand both what your design is and the process you used to get there. Present text and images in a logical order that helps readers follow your development process and results.

Maintaining a project notebook is a good business practice that will help to capture ideas and keep track of your company's progress – including your research, designs, trade studies, experiments, data, vehicle specifications, testing, expenditures, and donations. The notebook is also a place to write down your company member's contributions (time, support, etc.).

Along with your notebook, here are some items to consider as you prepare to tell your story via your documentation and presentation:

- What was your company's "work breakdown structure" (tasks, time, and people)?
- What were the greatest limitations (schedule, budget, equipment, labor, logistics, etc.) on your design process?
- How did the product demonstration and rules influence your design and decisions?
- What process, such as a [tradeoff matrix](#), did you use to evaluate competing design solutions?
- What were the most important design decisions you made and why?
- Did you have a noteworthy troubleshooting experience? Any problem or procedure that takes more than 20 minutes to figure out is worth understanding and writing down.

### **NEW IN 2018!!!**

Rather than specifications, this year your company should refer directly to the scoring rubrics posted on the MATE web site under [Missions, Specs, and Scoring](#) for details on what is required for your technical documentation, engineering presentation, and marketing display. The judges will use the rubrics to evaluate and score these engineering and communication components.

## **5.1 COMPANY SPEC SHEET (ONE PAGE ONLY)**

The goal of the Company Spec Sheet is to provide the judges with a "snapshot" of your company. It includes basic information about your company and vehicle.

Companies must submit their spec sheets to their [regional coordinator](#), along with (but as a separate document from) their technical documentation (see below).

Companies will receive up to 10 points for submitting a spec sheet that is one page in length and follows the file size and naming specifications and contains all of the following information:

#### COMPANY SPECS

- **Company and school, club, or community organization name**
- **Home state and/or country**
- **Distance required to travel to the international competition**
- **History of MATE ROV competition participation.** Be sure to specify if your company and/or the members of your company are “new” or “returning.”
- **Company photo and caption indicating members’ names and roles (e.g. CEO, CFO, Design Engineer, Pilot, etc.).** This photo should include all of the members of your company.
- **Range of grade/college levels represented by the members of your company**

#### ROV SPECS

- **ROV name** if applicable
- **Total cost.** You must include the approximate cost of any donated items.
- **Size** measurements
- **Total student-hours to design and build.** This should include the number of hours that each and every member of the company worked on the vehicle.
- **Safety features**
- **Special features**
- **Photo of the vehicle**

If all of the above information is included, the specifications for length, size, and naming conventions are followed carefully, and the document is submitted on time, this is an “easy” 20 points!

## 5.2 TECHNICAL DOCUMENTATION

Your company is required to submit technical documentation that will be reviewed and evaluated by a panel of working professionals – individuals who represent science, exploration, government, and industry. (Don’t assume that these same individuals will evaluate your company’s engineering presentation!) The technical documentation is a means for your company to describe the design, operations, and features of your vehicle. Your clients should gain a good technical understanding of your vehicle and your company’s capabilities in addressing your client’s needs for an ROV.

Each judge will evaluate and award a score (50 points max). Judges’ scores and comments will be returned to you shortly after the event.

Use the technical documentation scoring rubric posted [here](#) as the guideline for the required components for the technical documentation. This rubric will be posted by February 1, 2018.

### 5.3 ENGINEERING PRESENTATION

During the competition, your company will present to a panel of working professionals – individuals who represent science, exploration, government, and industry. .) Your presentation should describe the engineering behind your vehicle’s design and operation and address any possible safety issues. It should also highlight any design innovations or creative solutions to solving the product demonstration tasks. After the presentation, the judges will take 5 to 10 minutes to ask the members of your company questions about your ROV. The judges will evaluate both your presentation and responses to their questions and award a score (50 points max) based on your presentation and how you answer their questions.

**All student members of your company must participate in this presentation and question and answer (Q&A) period.** You are required to have your ROV with you. Be sure to organize your information and practice your presentation in advance. Ask your instructors, mentors, and parents for feedback. Practicing will help you to work out any “kinks” and be more comfortable talking in front of the judges.

Depending on your regional, this may be a presentation and a question and answer period OR a question and answer period ONLY. Either way, you should be prepared to talk about your vehicle and answer questions about it and your company.

**NOTE:** The product presentation is designed to be a face-to-face interaction between students and industry professionals. MATE will not provide audio visual aids, such as slide projectors, computer projection screens, white boards, etc.; however, you are welcome to distribute handouts to help judges better understand the information that you are presenting. **PowerPoint presentations are NOT permitted.** During the Q&A, all members of the company must be present and prepared to answer.

**Instructors, mentors, family members, friends, and members of other companies are permitted to attend.** However, we ask that those in attendance be respectful and courteous throughout the presentation and follow-up question and answer period. Be mindful that this presentation may be a stressful time for the students. If the room becomes crowded or the spectators become distracting, it is up to the judges’ discretion to request that some or all spectators leave the presentation. **While they are permitted to attend, instructors and mentors are not allowed to participate.**

Use the engineering presentation scoring rubric posted [here](#) as the guideline for the required components for the engineering presentation. This rubric will be posted by February 1, 2018. Judges may ask questions regarding any of these topics not covered in the presentation as well as other questions about the vehicle, the mission theme, or the company.

**Preparing for your product presentation:**



- Make sure that every member of your company has a good, general working knowledge of your vehicle, even though they may have specialized in one specific aspect of its design and construction.
- Research the specifications of the components that you use in your vehicle. Be familiar with such numbers as the amount of propulsive force the thrusters produce, the weight of your ROV, etc.
- Encourage each member of your company to keep a project notebook. Before the competition, set up a time where you compare notebooks. One member might have written more information about your ROV's electrical system, while another might have included details about buoyancy that others forgot. This exercise will help to refresh everyone's memory about the design and building process. If your company submitted technical documentation, make sure all company members have read it and are familiar with it. This exercise will help to familiarize everyone with all aspects of the project.
- Generally, you will have more to say about your ROV than can be presented in 5 or 10 minutes. That is why it is critical to organize your material and practice communicating it. However, avoid coming across as having memorized your presentation. Judges want to see that you are prepared and understand the information, not that you can simply recite a rehearsed speech from memory. Ask your instructors or mentors to give you feedback.

#### **Other important items**

- If during the engineering presentation it becomes apparent that instructors, mentors, and other adults associated with your company exercised more than an advisory role, judges reserve the right to deduct points or, in extreme cases, disqualify companies.

## **5.4 MARKETING DISPLAY**

Your company is required to create a display that will be showcased during the competition event. Your display should be an informative, clear, and concise presentation about your company and how you designed and built the specialized tools to effectively complete the product demonstrations. During the competition, your company's display will be evaluated and scored by a completely different group of working professionals – individuals who will represent science, business, government, industry, and education/outreach.

While some judges will have a technical background, others will have a communications, marketing, or public relations background. In addition, there will be visitors to the competition who may not completely understand what an ROV is or how it is used. Think of these visitors as potential future clients who may authorize funding for your work, but have a limited understanding of the technology (i.e., you need to explain your technology, the tasks at hand, and “sell” them on YOUR products and services). Design your display to communicate to this type of audience.

Each judge will award a score (50 points max). Judges' scores and comments will be returned to you shortly after the event.

Each company will have a space approximately 3-feet x 3-feet for its display. Depending on your regional, tables may or may not be provided. Contact your [regional coordinator](#) or visit your regional contest's website for more information.

**Use the marketing display scoring rubric posted [here](#) as the guideline for the required components for the marketing display. This rubric will be posted by February 1, 2018.**

**Creating an effective marketing display:**

- Address the theme and make real-world connections.
- Reflect your company's personality and mindset.
- Make key points and be concise.
- Keep the general public in mind.
- Make sure to label any and all figures, graphs, diagrams, and photographs and credit the source.
- Maximize the use of the 36" by 48" display space.
- Make sure that it is both informational and aesthetically pleasing.

**Note:** "Accessories" such as video footage, PowerPoint slide presentations running on laptop computers, video projections, etc. are permitted but should be used with discretion. Remember that the judges will have a limited amount of time to evaluate your marketing display and may find excessive use of audio or video presentations distracting.

However, if you do make a video of your ROV building or competition experience, please submit information about it to the [MATE Center](#) so that it can be shared via MATE's YouTube and Vimeo channels.

## **5.5 CORPORATE RESPONSIBILITY (formerly Outreach and Inspiration)**

The MATE Center uses underwater robotics to inspire and encourage students' interest in STEM (science, technology, engineering, and math) education and careers. Recognizing that the students who participate in MATE competitions are powerful spokespeople for the program as well as leaders in raising awareness of important issues and bringing about positive change, companies have the opportunity to earn up to 10 points for "corporate responsibility."

Corporate responsibility includes, but is not limited to, the following:

- **Mentoring** consists of, for example, providing guidance to other students in your area who are designing and building an ROV for the competition or a science or other project.
- **Engaging the community** includes demonstrating your ROV and sharing information about your company at festivities and other community-wide events. Presenting to a Rotary Club or your school districts board of directors are other examples.
- **Media outreach** consists of:

- Developing a list local media contacts
- Writing a press release about your participation in the MATE ROV competition
- Distributing it to your media contacts
- Following up with your media contacts to see if they're interested in your company and its ROV
- Compiling a summary of results

Here are some [general guidelines](#) for working with the media. They are specific to the international competition, but can be easily changed for regional events.

- **Raising awareness of societal (including environmental) issues** includes, for example, the amount of plastics in the world ocean. A 2010 study estimated that 8 million tons of plastic trash ended up in the ocean from coastal communities – far more than the total that has been measured floating on the surface in the ocean’s “garbage patches.” Even the deepest part of the ocean is not immune; a recent study published in Nature found that crustaceans collected at the bottom of the Marianas Trench had levels of plastic micro-particles at levels 50 times greater than that of the most polluted river in China. [Read more](#) – and take on the challenge!

Corporate responsibility efforts will be reviewed by competition coordinators and awarded 0 to 10 bonus points, depending on the number and scope of the outreach and awareness activity(s), i.e., the number of other students or members of the community engaged, the number of mentoring sessions, etc.

Make sure to include the following information in your write-up:

- Type of activity (e.g. mentoring, exhibiting at a community event, raising awareness)
- Locations, dates, and the amount of time spent on the activity
- Number of students or community members (if a large event, this can be an approximate) involved
- Description of your actions, outcomes, and other information that helps to demonstrate the quality of your time and efforts
- For media outreach, please submit a copy of your press release, a copy of your media contacts list, and a summary of news articles, TV or radio coverage, etc. that your company received. Include copies of articles and URLs, and list any television or radio coverage. Be sure to include name of outlet, date, and a summary of the coverage.

## PART 6: DOCUMENTATION AND KEY DEADLINES

Companies are required to submit a system interconnection diagram (SID) of their vehicle control system. Your regional may also require you to submit technical documentation and a company spec sheet.

Contact your [regional coordinator](#) or visit your regional contest's web site to determine what documentation must be submitted for your regional and the date it is due.

DOC-001: Technical documentation: A technical document or engineering notebook about your vehicle that will be reviewed by a panel of judges. See the [technical documentation](#) section for more information on the contents required for the technical documentation.

DOC-002: Company spec sheet: A one page document that provides a snapshot of your company and ROV. See the [company spec sheet](#) section for more information on the requirement for the company spec sheet.

DOC-003: SID Electrical: Companies must provide a [system interconnection diagram \(SID\)](#) of their vehicle control system during their safety inspection.

DOC-004: Fluid power SID: Companies using fluid power (hydraulics or pneumatics) must provide a fluid power diagram. The diagram should separate and show what systems are on the surface and what systems are on the vehicle. A fluid power SID for simple syringe hydraulics would consist of a syringe box on the surface connecting to a syringe box on the vehicle.

The fluid power SID can be incorporated into the Electrical SID or can be a separate, one page document.

DOC-005: Documents may be due before the competition or the day of the competition. Regardless, companies **MUST** bring a SID of their ROV systems in order to pass the safety inspection!

NOTE: By submitting your documentation, you are giving the MATE Center permission to publish these documents on its web site.