

# NAVIGATOR Class Safety Inspection Sheet Tutorial

COMPANY NAME: \_\_\_\_\_ COMPANY NUMBER: \_\_\_\_\_

**2014 MATE ROV COMPETITION  
EXPLORING THE GREAT LAKES  
NAVIGATOR CLASS SAFETY CHECK LIST**

Companies must bring this check list, the ROV, tether, surface controls and any other item used in the deployment and operation of the ROV. They will all be inspected as part of the safety check. In addition, documentation listed below must be provided to the Safety Judges during the inspection process.

<b>1.0 Documentation</b>	
	Electrical schematics & power distribution diagrams
	Fuse shown in electrical schematics?
	Pneumatics or Hydraulics Used? See item 4.0
<b>2.0 Physical</b>	
	Propellers are enclosed inside the frame of the ROV or shrouded such that they will not make contact with items outside of the ROV.
	No sharp edges or elements of ROV design that could cause injury to personnel or damage to pool surface.
	All items attached to ROV are secure and will not fall off.
	Hazardous items are identified and protection provided.
<b>3.0 Electrical</b>	
	Single attachment point to power source.
	Standard male Banana plugs to connect to MATE power source.
	15 amp Single Inline fuse or circuit breaker within 30cm of attachment point.
	Motors are waterproofed.
	No exposed copper or bare wire.
	All wiring securely fastened and properly sealed*.
	Any splices in tether are properly sealed*.
	Tether is properly secured at surface control point and at ROV.
	Surface controls: All wiring and devices properly secured.
	Surface controls: All control elements are mounted with wiring inside an enclosure.
	No AC power sources.
	Cameras/Monitors operate off the MATE 12VDC power supply through the single attachment point to power source.
<p>*Properly sealed means that the wires cannot be exposed to water. Tape only sealing will allow the conduction of electricity through water.</p> <p>At minimum joints must be soldered, then sealed with silicone sealant and then finally taped. For in water taping, silicone self-vulcanizing tape is preferred over thermoplastic tape. Male to male connectors are not allowed.</p>	

<b>4.0 Pneumatic / Hydraulic (if using)</b>	
	Pneumatic diagram?
	Hand or foot pump only? No electrical pump used?
	Uses Water or air Only?
	No pressure accumulators? No closed containers that air is being pumped into? All containers vent to pool?
	Buoyancy chamber vent holes at least 1/4" (6.35mm) diameter?
<b>5.0 Lasers</b>	
	No Lasers Present. - Not allowed in NAVIGATOR Class

INSPECTION #1	PASSED: 10
POINTS	
FAILED: Items to correct:	
INSPECTION #2	PASSED: 10
POINTS	
FAILED: Items to correct:	
INSPECTION #3	PASSED: 10
POINTS	
FAILED: Reason	
Cleared to enter the water:	
<p style="text-align: center;">_____ Signature of competition official</p>	
PASS/FAIL STAMP	

**Documentation** – All companies must bring an electrical schematic of their vehicle. If hydraulics or pneumatics are used, companies must provide a fluid power schematic.

**Physical** – The ROV will be inspected for any items that may be unsafe to the participants, divers or the facility.

**Electrical** – All electrically powered systems must run through a single point of connection and a single fuse (15 amps or less). All systems on the ROV (going into the water) with electricity running through them must be waterproof. **Electrical issues are the most common safety violation.**

**Pneumatic/Hydraulic** – Team may only use manually powered pumps (no electrical pumps). All containers that air is pumped into must be open to the water. Air and water are the only fluids companies may use in their fluid power systems.



# NAVIGATOR Class Safety Inspection Sheet Tutorial

## 1.0 Documentation:

### Schematic of a TriggerFish dual joystick controller.

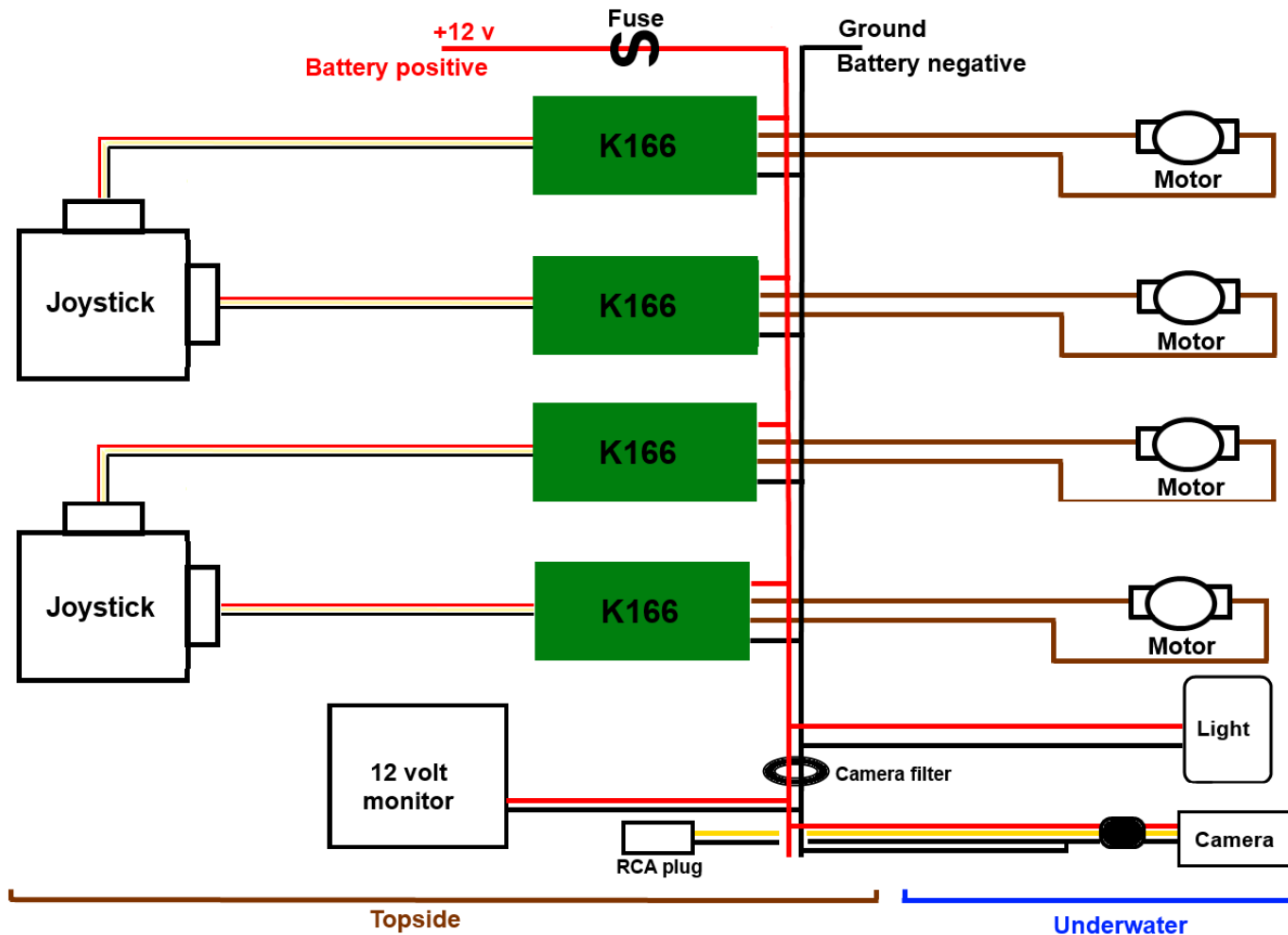

# NAVIGATOR Class Safety Inspection Sheet Tutorial

## 2.0 Physical

Propellers are enclosed inside the frame of the ROV or shrouded such that they will not make contact with items outside of the ROV.

Both examples are correct.

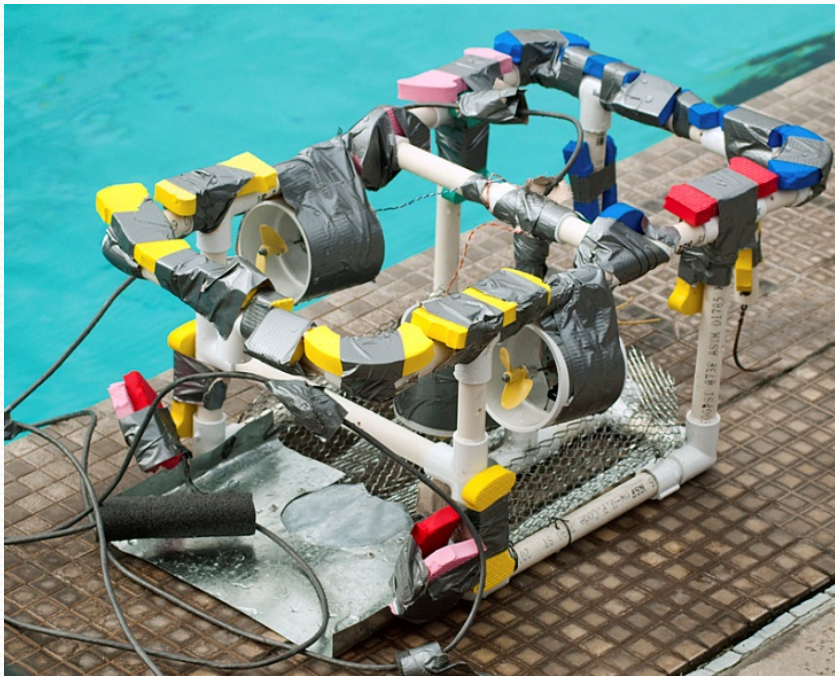

Shrouded



Inside the vehicle frame

# NAVIGATOR Class Safety Inspection Sheet Tutorial

## 2.0 Physical

All items attached to ROV are secure and will not fall off.

No sharp edges or elements that may cause injury or damage.

Motor is secured to ROV

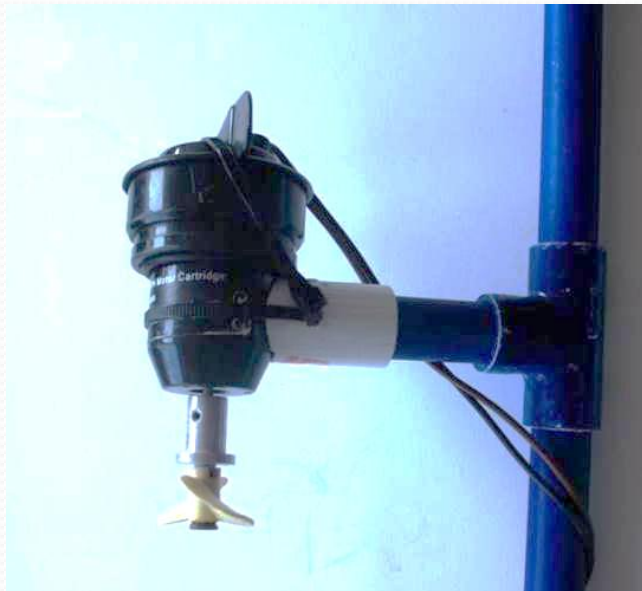

Sharp points are not allowed

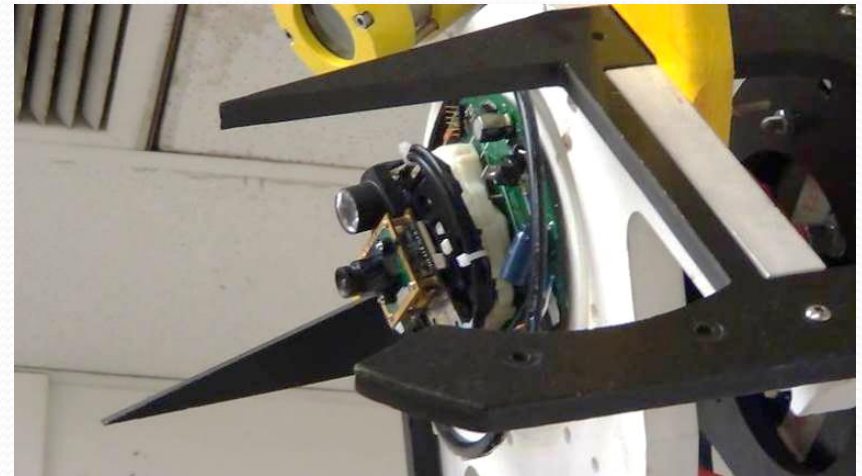

# NAVIGATOR Class Safety Inspection Sheet Tutorial

## 3.0 Electrical

Single attachment point to power source.

Standard male Banana plugs to connect to MATE power source.

Single Inline fuse within 30cm of attachment point.

**Correct** NAVIGATOR class power attachment is shown in both pictures. Fuse is within 30cm of the attachment points.

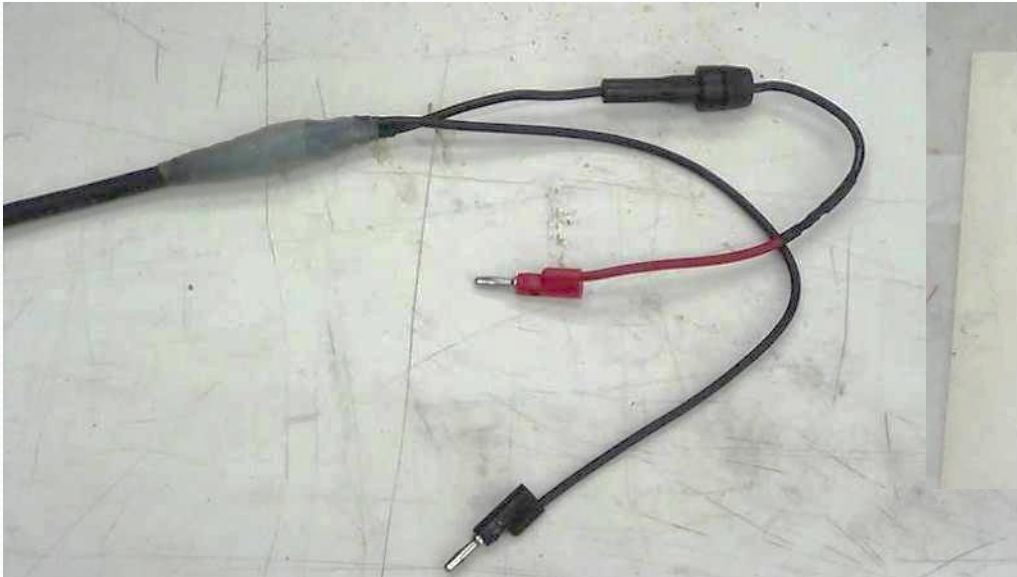

# NAVIGATOR Class Safety Inspection Sheet Tutorial

## 3.0 Electrical

This is an example of multiple attachments ahead of the fuse that **WILL NOT PASS**. Note that one line is properly fused, but two others are not fused.

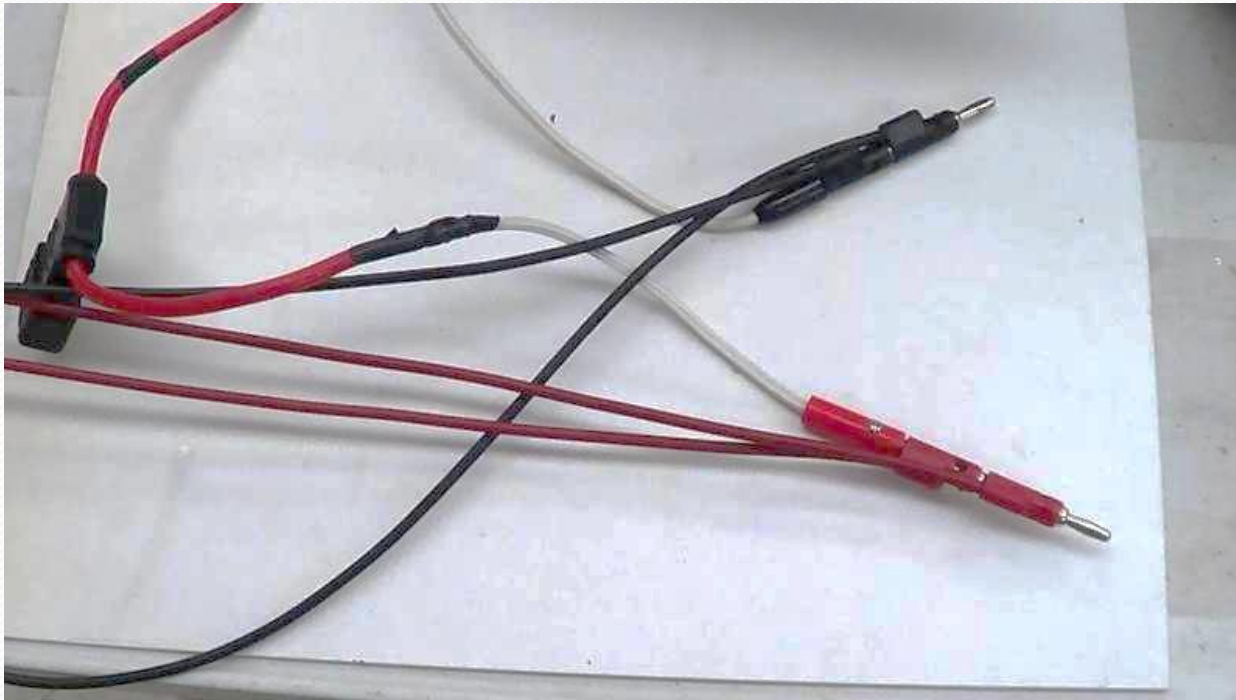

# NAVIGATOR Class Safety Inspection Sheet Tutorial

## 3.0 Electrical

No exposed copper or bare wire. No exposed motors. All wiring is properly sealed.

### Examples:

These **WILL NOT PASS**. The motor on the left is both exposed and has bare wire. The motor on the right is waterproof but the connections are not sealed. Tape over the connections is not sufficient. To properly waterproof connections, sealant or glue should be used underneath shrink wrap.

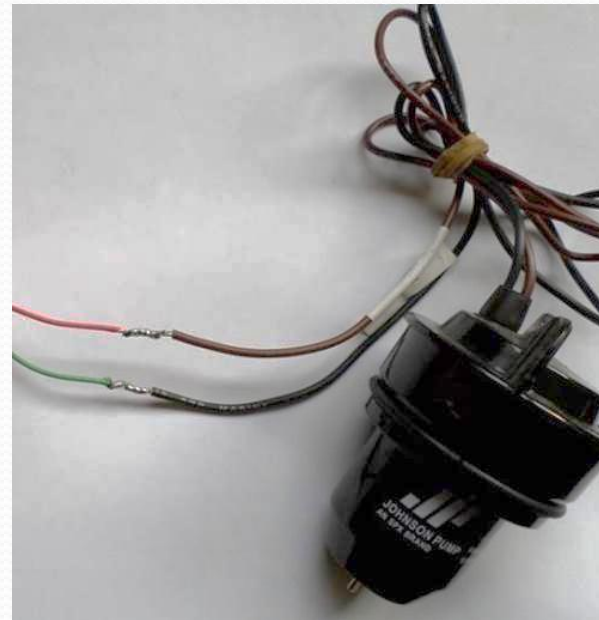

# NAVIGATOR Class Safety Inspection Sheet Tutorial

## 3.0 Electrical

Tether is properly secured at surface control point and at ROV.

### Examples:

This **WILL NOT** pass. The wires are loose and unsecured. They could entangle themselves in a propeller or with a mission prop.

Tether wires should be secured to the frame of the vehicle with tape, zip ties, or by another method.





# NAVIGATOR Class Safety Inspection Sheet Tutorial

## 3.0 Electrical

**Surface controls: All wiring and devices properly secured.**

**Surface controls: All control elements are mounted with wiring inside an enclosure.**

**Examples:**

**Although the wiring and control elements are mounted within an enclosure, there is no strain relief. If these wires were pulled, the strain would be directly onto the solder joints. A simple overhand knot tied inside the box works well as strain relief.**

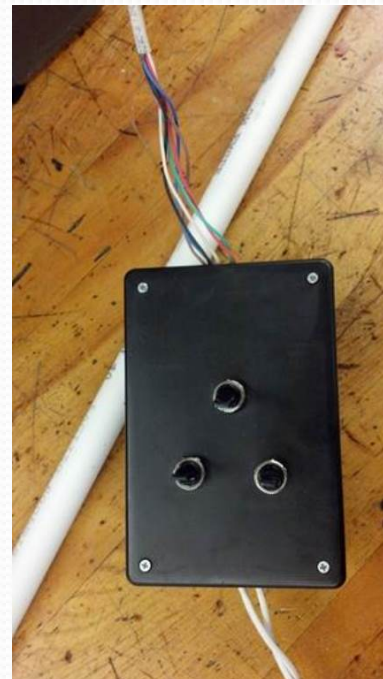

# NAVIGATOR Class Safety Inspection Sheet Tutorial

## 3.0 Electrical

Cameras **MUST** operate off the MATE 12VDC power source through the single attachment point and main system fuse. **NO CAMERAS MAY PLUG INTO AC POWER.** Cameras that plug directly into and draw power from a monitor that is plugged into AC are **NOT** allowed.  
**NO EXCEPTIONS.**

**No AC power** can be used to power the vehicle or its onboard components. AC plugs and wiring should not be used anywhere in the vehicle (even to carry DC power). **If there is an AC plug carrying DC, an inexperienced user may think the ROV plugs into the wall.**



# NAVIGATOR Class Safety Inspection Sheet Tutorial

## 4.0 Pneumatic / Hydraulic Checklist

Hand or foot pump only. No electrical pumps are allowed.

All buoyancy chambers must vent to the pool (holes in the bottom).

Vent holes are at least 1/4-inch in size.

Examples: Hand and foot pumps.

Buoyancy chamber opened at bottom.



## 5.0 Lasers

Lasers are not permitted on any vehicles.

**No exceptions.**



## NAVIGATOR Class Safety Inspection Sheet Tutorial

# Safety First!

Our goal is not to fail teams and keep them from competing, but rather to run a fair and **SAFE** competition for all.

If you have a question or concern, please contact the MATE Center at [izande@marinetech.org](mailto:izande@marinetech.org) or (831) 646-3082. In this case it is better to ask for permission, not forgiveness. Remember, it is better to be safe than sorry.

